

TEKAT

Crafting the Future of Cutting Performance

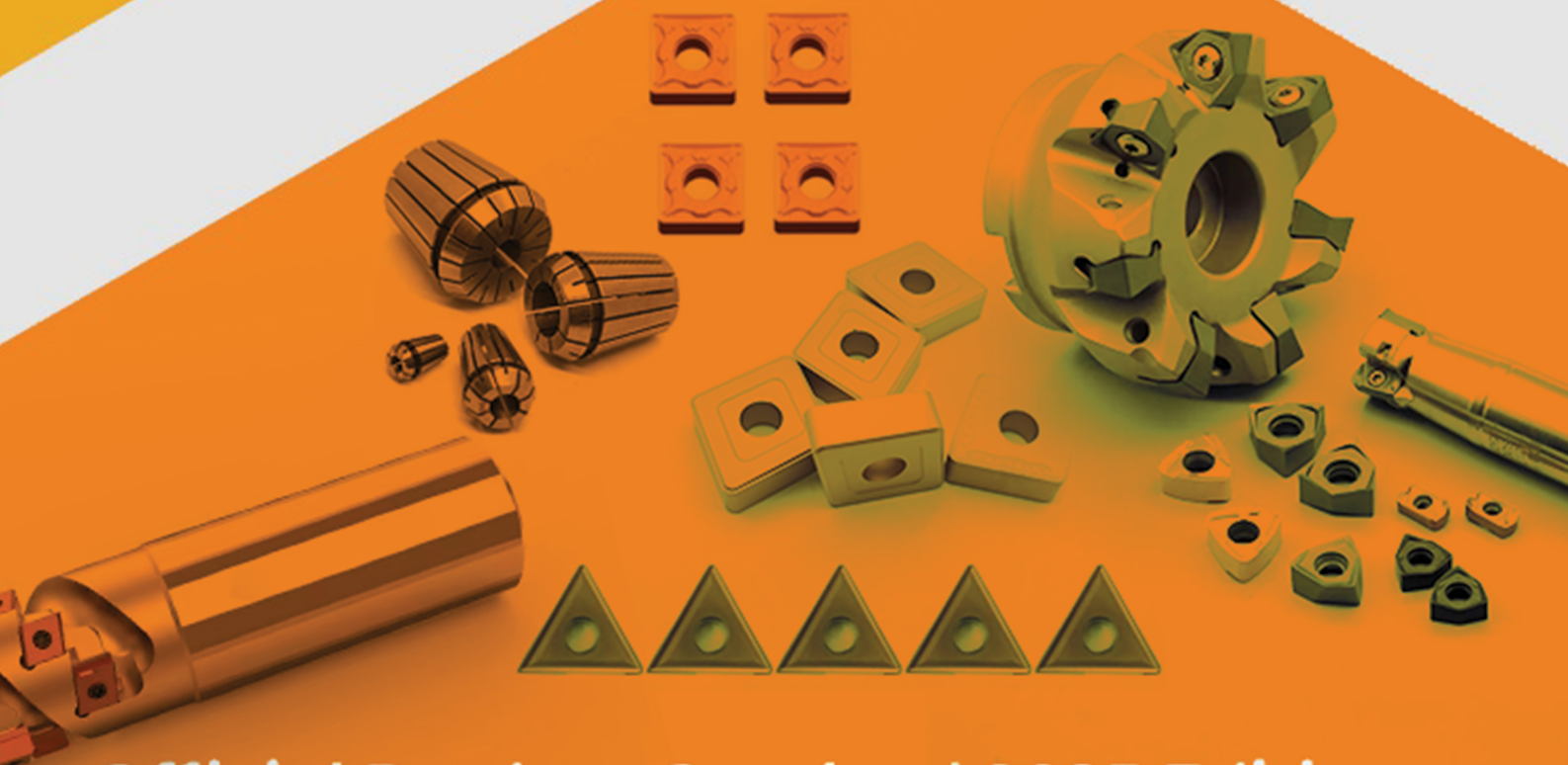

Official Product Catalog | 2025 Edition

Company profile

About TEKAT

TEKAT Precision Tools Co., Ltd. is a professional manufacturer dedicated to the development and production of high-performance cutting tools and industrial machinery. Located in Suzhou City, Jiangsu Province, China, TEKAT integrates advanced technology, precision engineering, and innovation to deliver solutions that empower global manufacturing.

Since our founding, TEKAT has focused on providing reliable, efficient, and durable CNC tooling solutions for a wide range of industries. Our main product lines include CNC inserts, milling cutters, turning tools, and customized precision components. With a team of skilled engineers and state-of-the-art facilities, we ensure every product meets international standards for performance and precision.

At TEKAT, customer satisfaction is the foundation of our philosophy. We continuously optimize our processes, enhance R&D capabilities, and enforce strict quality management systems to guarantee that each tool we produce exceeds client expectations in quality and value.

Driven by innovation and excellence, TEKAT aims to become a globally recognized leader in the CNC tool industry. Whether serving domestic or overseas markets, we are committed to creating sustainable partnerships and contributing to the progress of modern manufacturing.

Address:

TEKAT Precision Tools Co., Ltd.
No. 88 Innovation Road, Suzhou Industrial Park,
Suzhou City, Jiangsu Province, China 215021



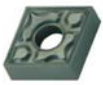

Turning inserts ----- P001-031



External turning tools ----- P032-077



Internal turning tools ----- P078-113



Grooving and parting tools ----- P114-134



Threading tools ----- P136-160



Milling tools ----- P162-204



Boring tools & drilling tools ----- P206-232



Tool Holder Series ----- P234-262



Solid carbide drills & taps ----- P264-277



Turning Inserts

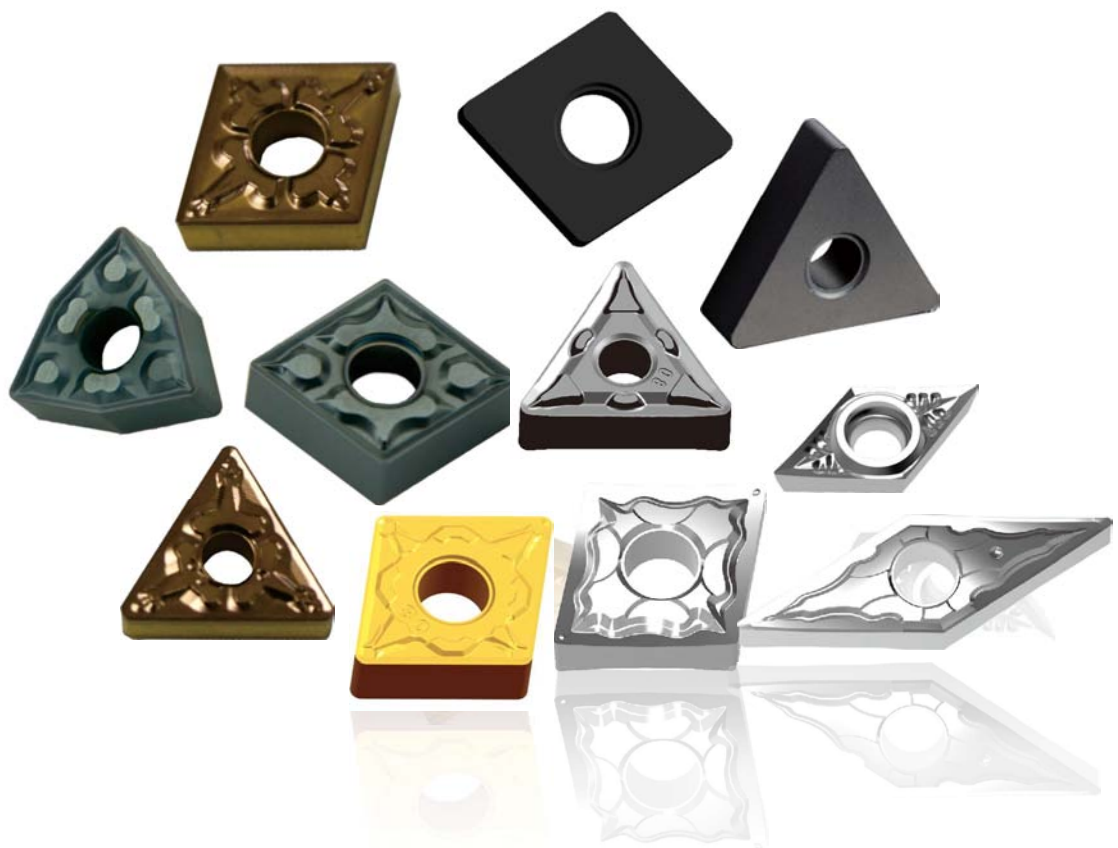

NFM Geometry case study

- The sharp cutting edge, cutting a high sharpness
- double front angle design, two-way guarantee sharpness and high strength
- full week double chip breaking groove, high versatility, is suitable for various conditions

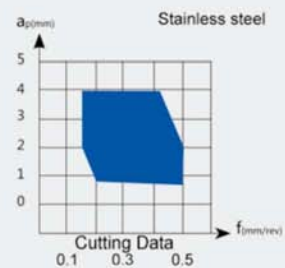
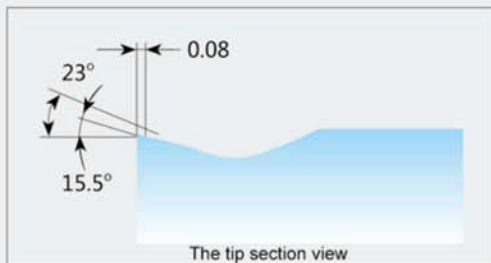
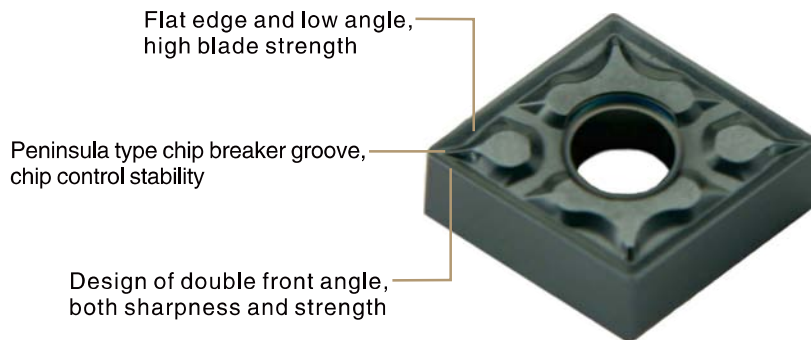

Case 1



Workpiece material	316(HB200)Stainless steel
Machining parts	The outer circle facing
Insert	TNMG160404-NFM/NS4125

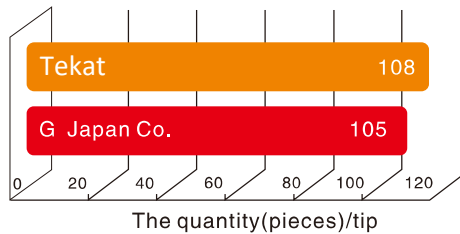

The cutting parameters
 $V_c=106\text{m/min}$
 $f=0.1\text{mm/r}$
 $a_p=0.5\text{mm}$

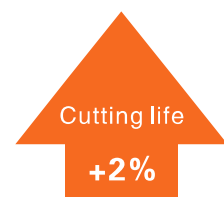

Turning inserts

External turning

Internal turning

Grooving & parting

Threading

Milling

Boring & drilling

Tool holder

Solid carbide end mills

Solid carbide drill & taps

Technical information

NGM Geometry case study

Variable edge width

- Good balance of sharpness and strength due to Variableland

Strengthening rib

- Strengthening rib decreases the contact area between the insert surface and chips

Gradient and waved hump

- Good chip control at low depth of cut and broadened cutting region due to gradient and waved hump

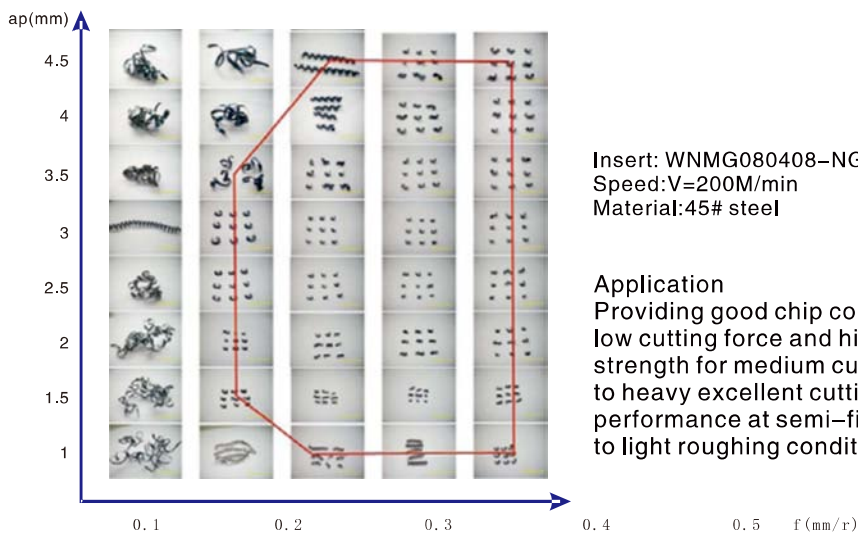
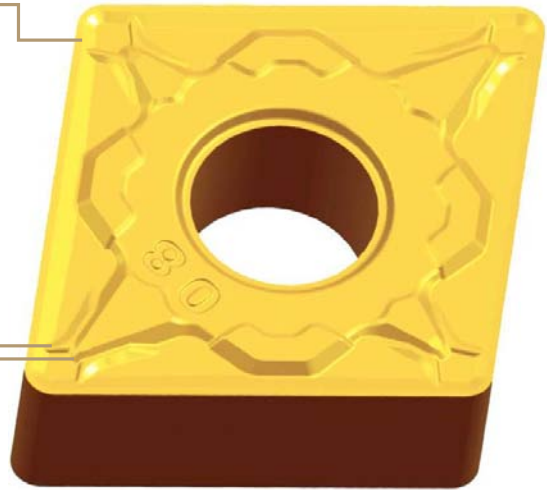

Insert: WNMG080408-NGM-NP1225
 Speed: V=200M/min
 Material: 45# steel

Application
 Providing good chip control, low cutting force and high edge strength for medium cutting to heavy excellent cutting performance at semi-finishing to light roughing condition.

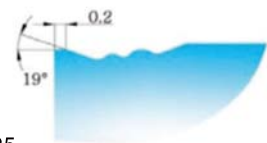

Cross Section Geometry

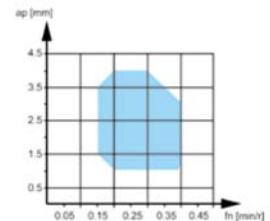

Applicable Chipbreaker

Case 1



Workpiece material	Cr15(HB160-180)
Machining parts	OD and face finishing
Insert	WNMG080408-NGM NP1225



The cutting parameters
 $V_c=285\text{m/min}$
 $f=0.2\text{mm/r}$
 $a_p=0.55\text{mm}$

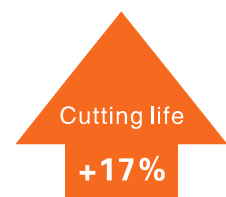

NF Geometry case study

Curved edge

- Well-balanced combination of sharpness and toughness, smooth chip discharge due to curved edge

The butterfly sharp dots at the knifepoint

- Changed chip flow and improved chip control at small depth of cut due to twin dots near corner

Variable Rake Angle

- Variable rake angle provides enough edge strength at difference depth of cut

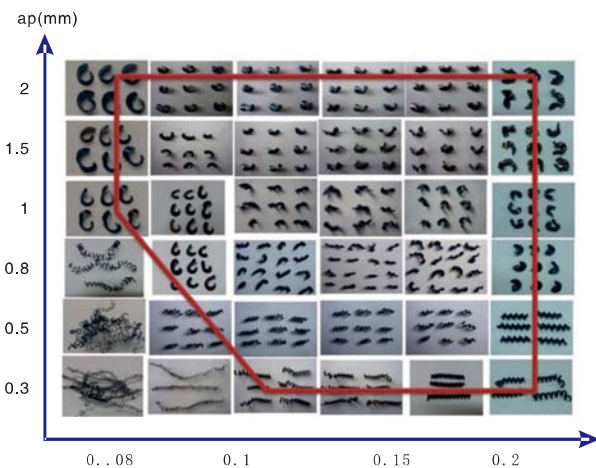
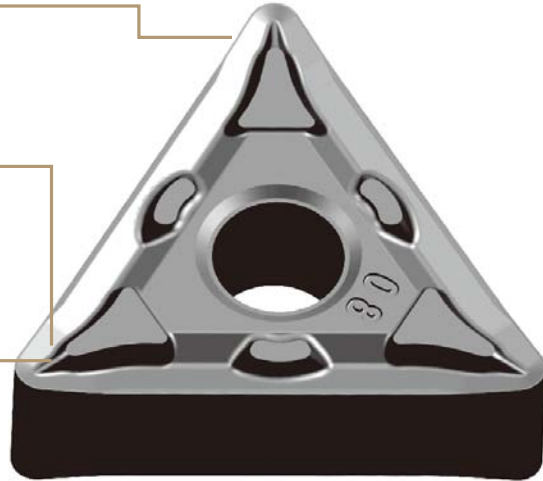

Insert: CNMG120404-NF-NS4125
Speed: V=180M/min
Material: 45# steel

Application

Good chip control with an excellent surface finish at small depths of cut. Suitable for finishing of steel and excellent cutting performance at small depths of cut and low feeds.

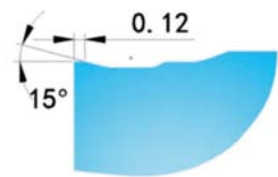

Cross Section Geometry

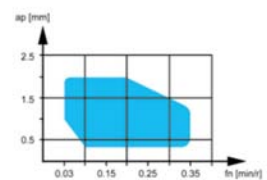

Applicable Chipbreaker

Case 1



Workpiece material	QCM8(HB160-200)
Machining parts	OD and face finishing
Insert	TNMG160404-NF/NS4125

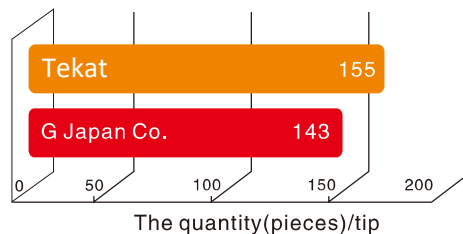

The cutting parameters
Vc=155m/min
f=0.12mm/r
ap=0.2mm

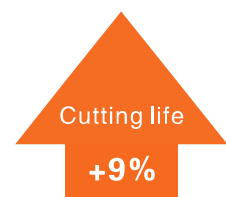

NK2 Geometry case study

Peculiarity

- Wide edge and groove and shallow groove depth combination, can achieve high feed processing and cutting stability
- The strength of the tool tip, in interrupted cutting and descaling cutting performance;
- In turning of cast iron, cutting resistance than flat blade small, extend tool life, the cutting performance;

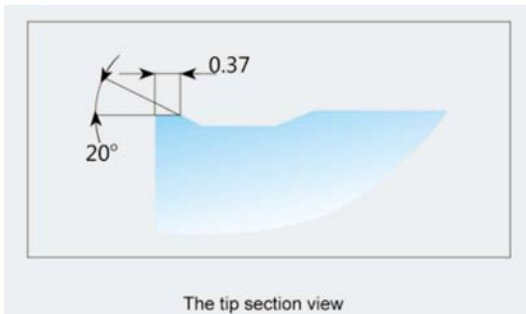

A large shallow groove, groove depth, so that the chip resistance

Wide edge, edge strength



Case 1



Workpiece material	HT250(HB190)
Machining parts	End, cylindrical semi finish turning
Insert	TNMG220412-NK2/NK1115

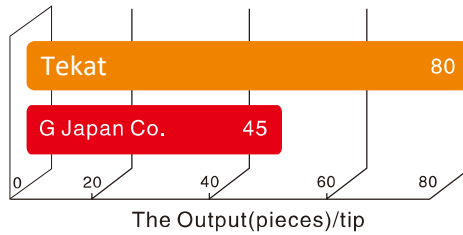

The cutting parameters
 $V_c=510\text{m/min}$
 $f=0.3\text{mm/r}$
 $a_p=1\text{mm}$

Cutting life
+78%

Case 2



Workpiece material	QT450-10(HB200)
Machining parts	The outer circle surface finishing, intermittent
Insert	WNMG080412-NK2/NK1125

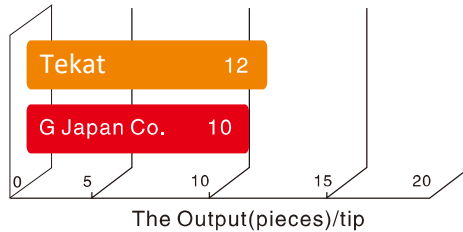

The cutting parameters
 $V_c=293\text{m/min}$
 $f=0.18\text{mm/r}$
 $a_p=1.5\text{mm}$

Cutting life
+20%

NF Geometry case study

Peculiarity

NF groove insert series, good versatility, stable life, paired with a variety of brands, widely used in a variety of materials round cars drilling and boring.

Flat edge and low angle, high blade strength

Peninsula type chip breaker groove, chip control stability

Design of double front angle, both sharpness and strength

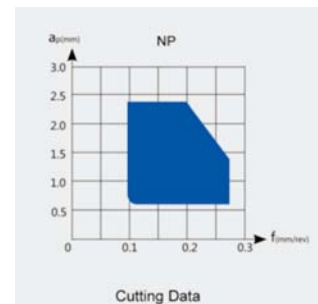
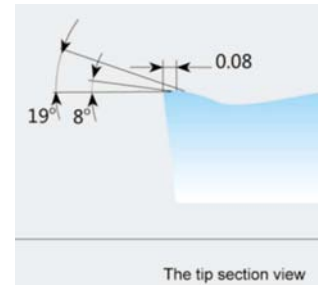

Case 1

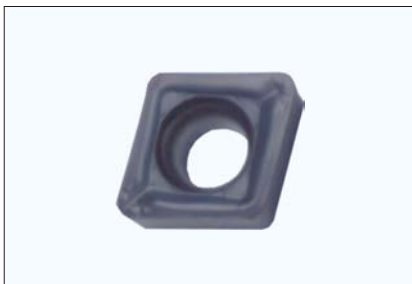

Workpiece material	S45CVS
Machining parts	The outer circle facing
Insert	CCMT09T308-NF/NS4125

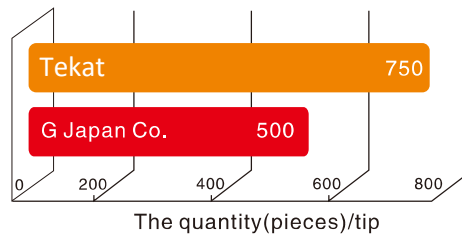

The cutting parameters
 $V_c=110\text{m/min}$
 $f=0.2\text{mm/r}$
 $a_p=2\text{mm}$

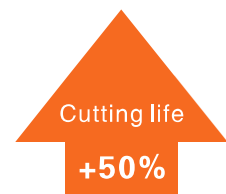

Case 2



Workpiece material	S45CVS
Machining parts	The inner hole machining
Insert	TCMT16T304-NF/NF4125

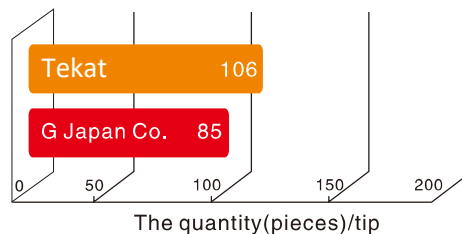

The cutting parameters
 $V_c=160\text{m/min}$
 $f=0.16\text{mm/r}$
 $a_p=1.5\text{mm}$

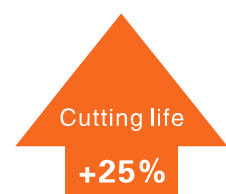

NL Geometry case study

- New polishing process
- The tip is sharpness
- Superior wear resistance
- Chipping stably
- Greatly inhibit the formation o the development humor
- Chipping smoothly
- Very slow cutting resistance, to prevent deformation
- Excellent quality of processing the machine surface
- Adopting new grade of NN9125 and having abrasion resistance and toughness
- Which is open type geometry and the chip flow to the tough surface

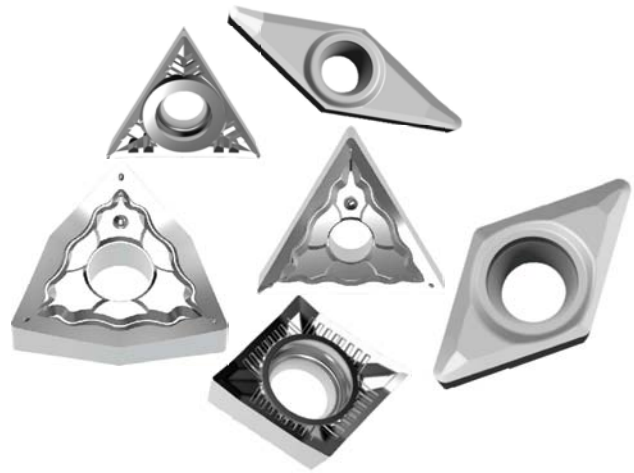

Case 1



Workpiece material	A356
Machining parts	Longitudinal and face roughing
Insert	WNGG080408-NL-NN9115

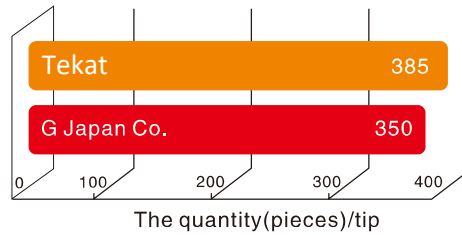

The cutting parameters
 $V_c=500\text{m/min}$
 $f=0.5\text{mm/r}$
 $a_p=1.5\text{mm}$

Cutting life
+10%

Case 2



Workpiece material	A356
Machining parts	Internal processing
Insert	CCGT09T304-NL-NN9115



The cutting parameters
 $V_c=460\text{m/min}$
 $f=0.16\text{mm/r}$
 $a_p=0.8\text{mm}$

Cutting life
+7%

Turning Insert Grades

1. Grades for P Applications



Grade	Cutting Range	Coating	Advantages
TP1115	Finishing and Semi-finishing		<ul style="list-style-type: none"> ● Super fine MT-TiCN, Al₂O₃ and TiN coating on carbide substrate, smooth surface and superior wear resistance. ● Application: Suitable for the cutting of steel and alloy steel in continuous conditions.
TP1125	Semi-finishing to Light Roughing		<ul style="list-style-type: none"> ● Super fine MT-TiCN, Al₂O₃ and TiN coating on graded carbide substrate, smooth surface and superior wear resistance and improved toughness. ● Application: Suitable for the cutting of steel and alloy steel in light interrupted
TP1135	Roughing		<ul style="list-style-type: none"> ● Super fine MT-TiCN, Al₂O₃ and TiN coating on graded carbide substrate, smooth surface and superior fracture resistance. ● Application: Suitable for cutting of steel and alloy steel under interrupted conditions.
TP115T	Finishing and semi-finishing		<ul style="list-style-type: none"> ● Cermet grade with High wear resistance and good roughness. ● Application: For turning of steel, cast iron and stainless steel in continuous conditions.
TP9125	Semi-finishing and Roughing		<ul style="list-style-type: none"> ● Micro-grain carbide substrate with high hardness and superior wear resistance. ● Application: Suitable for cutting of copper and aluminum alloys in light interrupted conditions.

2. Grades for M-S Applications

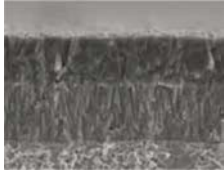

Grade	Cutting Range	Coating	Advantages
TM1125	Semi-finishing		<ul style="list-style-type: none"> ● TiCN and TiN coating on good toughness carbide substrate, with good wear resistance, superior adhesion resistance and longer tool life. ● Application: Suitable for stain less steel cutting in continuous and light interrupted conditions.
TM3125	Semi-finishing and Roughing		<ul style="list-style-type: none"> ● TiAlN coating on super micro grain carbide substrate with superior resistance to thermal shock, mechanical shock and good wear resistance. ● Application: Suitable for stainless steel cutting in light interrupted conditions.

Turning Insert Grades

3. Grades for K Applications

Grade	Cutting Range	Coating	Advantages
TK1115	Finishing and Semi-finishing		<ul style="list-style-type: none"> ● MT-TiCN and thick Al₂O₃ coated on micro-grain carbide substrate, superior wear resistance, Special post-processing with smooth coating and smooth coating and shows superior wear resistance and fracture resistance. ● Application: Suitable for nodular iron and gray iron in continuous and light interrupted conditions.
TK1125	Semi-finishing and Roughing		<ul style="list-style-type: none"> ● Thick MT-TiCN+Al₂O₃ coated on toughness micro-grain carbide substrate, keeping superior wear resistance and greatly improved toughness. ● Appl cat on Su table for bad mach n ng cond t ons wh ch requ re h gh toughness.

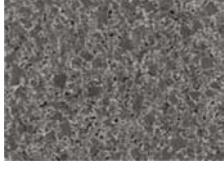
4. Grades for N Applications

TN9115	Semi-finishing and Roughing		<ul style="list-style-type: none"> ● Micro-grain carbide substrate with high hardness and superior wear resistance. ● Application: Suitable for cutting of copper and aluminum alloys in light interrupted cond t ons.
TPCD9115	Semi-finishing and Roughing		<ul style="list-style-type: none"> ● High density s ntered by super fine d amond gra ns ,have h ghest wear res stance and fracture res stance,excellent shape edge also

5. Grades for S Applications

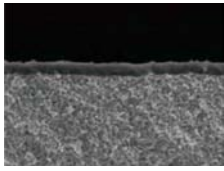
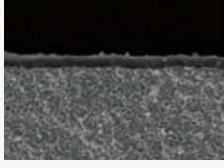
TS4115	Semi-finishing to Light Roughing		<ul style="list-style-type: none"> ● Nano-structure AlCrN coating on super micro-grain carbide. ● Application: Suitable for medium milling of P&K materials under dry and wet cutting conditions.
TS4125	Semi-finishing and Roughing		<ul style="list-style-type: none"> ● The new upgrade TiAlN+ coating has excellent heat resistance and oxidation resistance. ● Due to the high adhesion strength to the substrate NS4125 can achieve a reliable tool

6. Grades for H Applications

TBCN9115	F n sh ng		<ul style="list-style-type: none"> ● Fine gra n s ze, h gh CBN content and metal b nder system. ● High abras on res stance,outsand ng mpact strength,strength, excellent edge qual ty and fine surface
----------	-----------	--	--

Application Summary of Turning Grades

Workpiece	ISO	Coated		Uncoated	Cermet	PCD	CBN
		CVD	PVD				
P Steel	P10	TP1115	TS4115		TP115T		
	P20	TP1125	TS4125		TP115T		
	P30	TP1135	TS7912				
	P40	TS7911	TS7912				
M Stainless Steel	M10		TM3125		TP115T		
	M20		TM1125				
	M30		TM3125				
	M40		TS4125				
K Cast Iron	K10	TK1115	TS4115		TP115T		TCBN9115
	K20	TK1125	TS4125				
	K30		TK7915				
	K40		TS4125				
N Non-ferrous Metal	N10			TN9115		TPCD9115	
	N20						
	N30						
	N40						
S Heat-resistant Alloy, TiAlloy	S10		TS4115				
	S20		TS4125				
	S30						
	S40						
H High Hardness Materials	H10			TN9115			TCBN9115
	H20	TH7936					
	H30						
	H40						

Turning Inserts

External turning

Internal turning

Grooving & parting

Threading

Milling

Boring & drilling

Tool holder

Solid carbide end mills

Solid carbide drill & taps

Technical information

Workpiece Material Table

	ISO Material Group	Workpiece Material	Carbon Content	Tensile Strength N/mm ²	Brinell Hardness HB	Rockwell Hardness HRC
P Steel	P1	Low-carbon Steels, Long Chipping.	C<0.25%	<530	<125	
	P2	Low-carbon Steels, Short Chipping, Free-cutting Steels.	C<0.25%	<530	<125	
	P3	High-carbon Steels, Medium-carbon Steels.	C<0.25%	<530	<220	<25
	P4	Alloy Steels, Tool Steels.	C<0.25%	600-850	<330	<35
	P5	Alloy Steels, Tool Steels.	C<0.25%	850-1400	340-450	35-48
	P6	Ferritic Stainless Steels, Martensitic Stainless Steels, PH Stainless Steels.	C=(0-0.4)%	600-900	<330	<35
	P7	High-strength Ferritic Stainless Steels, Martensitic Stainless Steels, PH Stainless Steels	C=(0.1-0.6)%	900-1350	330-450	35-48
M Stainless Steel	M1	Austenitic Stainless Steels.	C=(0.05-0.15)%	<600	130-200	
	M2	High-strength Austenitic Stainless Steels and Cast Stainless Steels.	C=(0.05-0.15)%	600-800	150-230	<25
	M3	Duplex Stainless Steels.	C=(0.05-0.20)%	<800	135-275	<30
K Cast Iron	K1	Grey Cast Iron.		125-500	120-290	<32
	K2	Moderately Difficult Alloy Cast iron, Nodular Cast Iron.		<600	130-260	<28
	K3	Difficult High-alloy Cast Iron, Nodular Cast Iron.		>600	180-350	<43
N Non-ferrous Metal	N1	Wrought Aluminium Alloys.		<520	60-90	
	N2	Cast Aluminium Alloys.	Si≤12%	<350	70-100	
	N3	Cast Aluminium Alloys.	Si>12%	200-320	60-120	
	N4	Copper, Copper Alloys.		200-650	60-200	
	N5	Graphite, CFK, CFRP Graphite, Composite Materials.		600-1500		
	N6	GFK, CFK Aluminium-based Composite Materials.		<700	<210	
S Heat-resistant Alloy, TiAlloy	S1	Iron-based Heat-resistant Alloys.		500-1200	160-260	25-48
	S2	Cobalt-based Heat-resistant Alloys.		1000-1450	250-450	25-48
	S3	Nickel-based Heat-resistant Alloys.		600-1700	160-450	<48
	S4	Titanium and Titanium Alloys.		900-1600	300-400	33-48
H High Hardness Materials	H1	Hardened S Steels.				45-55
	H2	Hardened S Steels.				55-60
	H3	Hardened S Steels.				60-65
	H4	Hardened Steels.				>65

- Turning inserts
- External turning
- Internal turning
- Grooving & parting
- Threading
- Milling
- Boring & drilling
- Tool holder
- Solid carbide end mills
- Solid carbide drill & taps
- Technical information

Cutting Speed Recommendation Table

Workpiece Material		Cutting Speed (Vc=m/min)		Feed Rate (f=mm/rev)		Cutting Depth (ap=mm)	
		TP9115	TP1115/TP1225	TP9115	TP1115/TP1225	TP9115	TP1115/NP1225
P Steel	Low-carbon Steels	180-300	150-250	0.1-0.6	0.1-0.8	0.5-3.0	1.0-5.0
	Medium-carbon Steels	150-250	120-200	0.1-0.5	0.1-0.6	0.5-2	1.0-5.0
	Alloy Steels	120-200	100-180	0.1-0.4	0.1-0.5	0.5-1.5	1.0-4.0
	tools Steels	100-180	80-160	0.1-0.4	0.1-0.5	0.5-1.5	1.0-4.0

Workpiece Material		Cutting Speed (Vc=m/min)		Feed Rate (f=mm/rev)		Cutting Depth (ap=mm)	
		TM1125/NM3125	S4115/NS4125	TM1125/TM3125	TS4115/TS4125	TM1125/TM3125	TS4115/TS4125
M Stainless Steel	Austenitic	150-250	150-250	0.1-0.5	0.1-0.5	0.5-3.5	0.5-3.5
	High-Strength Austenitic	120-200	120-200	0.1-0.4	0.1-0.4	0.5-3.0	0.5-3.0
	Cast Stainless Steels	100-180	100-180	0.1-0.35	0.1-0.35	0.5-2.0	0.5-2.0
	Duplex Stainless Steels.	80-160	80-160	0.1-0.35	0.1-0.35	0.5-2.0	0.5-2.0

Workpiece Material		Cutting Speed (Vc=m/min)		Feed Rate (f=mm/rev)		Cutting Depth (ap=mm)	
		TK1115/TK1125	TS4115/TS4125	K1115/TK1125	TS4115/TS4125	TK1115/TK1125	TS4115/TS4125
K Cast Iron	Grey Cast Iron	200-350	180-300	0.1-0.5	0.1-0.5	1.0-5.0	1.0-5.0
	Alloy Cast Iron,	200-400	150-250	0.1-0.4	0.1-0.4	1.0-5.0	1.0-5.0
	Nodular Cast Iron.	120-250	120-200	0.1-0.35	0.1-0.35	1.0-4.0	1.0-4.0

Workpiece Material		Cutting Speed (Vc=m/min)		Feed Rate (f=mm/rev)		Cutting Depth (ap=mm)	
		TN9115	TPCD115	TN9115	TPCD115	TN9115	TPCD115
N Non-ferrous Metal	Wrought Aluminium	400-800	600-1800	0.05-0.25	0.05-0.30	0.5-3.0	0.5-3.0
	Cast Aluminium	300-600	500-1600	0.05-0.25	0.05-0.30	0.5-3.0	0.5-3.0
	Copper, Copper	200-400	200-600	0.05-0.25	0.05-0.30	0.5-3.0	0.5-3.0
	composite Materials	400-800	400-1200	0.05-0.25	0.05-0.30	0.5-3.0	0.5-3.0

Workpiece Material		Cutting Speed (Vc=m/min)		Feed Rate (f=mm/rev)		Cutting Depth (ap=mm)	
		TS4115	TS4125	TS4115	TS4125	TS4115	TS4125
S Heat-resistant Alloy, TiAlloy	Iron-based Alloys	40-100	40-100	0.05-0.2	0.05-0.2	0.5-3.5	0.5-3.5
	Cobalt-based Alloys	40-100	40-100	0.05-0.2	0.05-0.2	0.5-3.0	0.5-3.0
	Nickel-based Alloys	40-100	40-100	0.05-0.2	0.05-0.2	0.5-2.0	0.5-2.0
	Titanium Alloys	40-100	40-100	0.05-0.2	0.05-0.2	0.5-2.0	0.5-2.0

Workpiece Material		Cutting Speed (Vc=m/min)		Feed Rate (f=mm/rev)		Cutting Depth (ap=mm)	
		TCBN115		TCBN115		TCBN115	
H High Hardness Materials	Hardened HRC45-55	120-250		0.05-0.20		0.3-1.0	
	Hardened HRC55-60	120-250		0.05-0.20		0.3-1.0	
	Hardened HRC60-65	120-250		0.05-0.20		0.3-1.0	

Turning Inserts

External turning

Internal turning

Grooving & parting

Threading

Milling

Boring & drilling

Tool holder

Solid carbide end mills

Solid carbide drill & taps

Technical information

ISO Turning Indexable Inserts Identification System

Symbol	Shape	ComerAngle	Figure
H	Hexagon	120°	
O	Octagon	135°	
P	Pentagon	108°	
S	Square	90°	
T	Triangle	60°	
C	Rhombic	80°	
D		55°	
E		75°	
F		50°	
M		86°	
V		35°	
W	Trigon	80°	
L	Rectangle	90°	
A	Parallelogram	85°	
B		82°	
K		55°	
R		Round	

① Shape Symbol

Symbol	Relief Angle
A	3°
B	5°
C	7°
D	15°
E	20°
F	25°
G	30°
N	0°
P	11°
O	Other

② Relief Angle Symbol

Symbol	Tolerance(mm)			Tolerance(inch)		
	Corner Height(m)	Thickness(S)	I.C.Size(ød)	Corner Height(m)	Thickness(S)	I.C.Size(ød)
A	± 0.005	± 0.025	± 0.025	± 0.0002	± 0.001	± 0.001
F	± 0.005	± 0.025	± 0.013	± 0.0002	± 0.001	± 0.0005
C	± 0.013	± 0.025	± 0.025	± 0.0005	± 0.001	± 0.001
H	± 0.013	± 0.025	± 0.013	± 0.0005	± 0.001	± 0.0005
E	± 0.025	± 0.025	± 0.025	± 0.001	± 0.001	± 0.001
G	± 0.025	± 0.013	± 0.025	± 0.001	± 0.005	± 0.001
J	± 0.005	± 0.025	± 0.05 - ± 0.13	± 0.0002	± 0.001	± 0.002 - ± 0.005
K	± 0.013	± 0.025	± 0.05 - ± 0.13	± 0.0005	± 0.001	± 0.002 - ± 0.005
L	± 0.025	± 0.025	± 0.05 - ± 0.13	± 0.001	± 0.001	± 0.002 - ± 0.005
M	± 0.08 - ± 0.18	± 0.013	± 0.05 - ± 0.13	± 0.003 - ± 0.007	± 0.005	± 0.002 - ± 0.005
N	± 0.08 - ± 0.18	± 0.025	± 0.05 - ± 0.13	± 0.003 - ± 0.007	± 0.001	± 0.002 - ± 0.005
U	± 0.13 - ± 0.38	± 0.013	± 0.08 - ± 0.25	± 0.005 - ± 0.015	± 0.005	± 0.003 - ± 0.01

③ Relief Angle Symbol

① ② ③ ④ ⑤

T N M G 22

① ② ③ ④ ⑤

④ Chipbreaker/Hole Symbol				
Symbol	Hole	Hole Shape	Chipbreaker	Shape
N	Without	—	Without	
R			Single-sided	
F			Double-sided	
A	With Hole	With Hole	Without	
M			Single-sided	
G			Double-sided	
W			Without	
T	With	With hole and one countersink 40° ~ 60°	Single-sided	
Q			Without	
U	With	With hole and two countersink 40° ~ 60°	Double-sided	
B			Without	
H	With	With hole and one countersink 70° ~ 90°	Single-sided	
C			Without	
J	With	With hole and two countersink 70° ~ 90°	Double-sided	
X			—	

⑤ Cutting Edge Length Symbol(ISO)(mm)																
P ₁		S		C		W		T		D		V		K		I.C.Size (mm)
Symbol	Length	Symbol	Length	Symbol	Length	Symbol	Length	Symbol	Length	Symbol	Length	Symbol	Length	Symbol	Length	
		03	3.97	03	4.0			06	6.9	4	4.8					3.97
		04	4.76	04	4.8			08	8.2	5	5.8					4.76
05	5	—	—	—	—	—	—	—	—	—	—	—	—	—	—	5
		05	5.56	05	5.6	03	3.8	09	9.6	6	6.8					5.56
06	6	—	—	—	—	—	—	—	—	—	—	—	—	—	—	6
		06	6.35	06	6.5	04	4.3	11	11	7	7.8	11	11.2			6.35
		07	7.94	08	8.1	05	5.4	13	13.8	9	9.7					7.94
08	8	—	—	—	—	—	—	—	—	—	—	—	—	—	—	8
09	9.525	09	9.525	09	9.7	06	6.5	16	16.5	11	11.6	16	16.6	16	19.7	9.525
10	10	—	—	—	—	—	—	—	—	—	—	—	—	—	—	10
12	12	—	—	—	—	—	—	—	—	—	—	—	—	—	—	12
12	12.7	12	12.7	12	12.9	08	8.7	22	22	15	15.5	22	22.1			12.7
15	15.875	15	15.875	16	16.1	10	10.9	27	27.5	19	19.4					15.875
16	16	—	—	—	—	—	—	—	—	—	—	—	—	—	—	16
19	19.05	19	19.05	19	19.3	13	13	33	33	23	23.3					19.05
20	20	—	—	—	—	—	—	—	—	—	—	—	—	—	—	20
		22	22.225	22	22.6			38	38.5	27	27.1					22.225
25	25	—	—	—	—	—	—	—	—	—	—	—	—	—	—	25
25	25.4	25	25.4	25	25.8			44	44	31	31					25.4
31	31.75	31	31.75	32	32.2			55	55	38	38.8					31.75
31	32	—	—	—	—	—	—	—	—	—	—	—	—	—	—	32

- Turning inserts
- External turning
- Internal turning
- Grooving & parting
- Threading
- Milling
- Boring & drilling
- Tool holder
- Solid carbide end mills
- Solid carbide drill & taps
- Technical information

Insert Shape:H.O.P.S.T.C.E.M.W.R									
I.C. Size (mm)	Tolerance of I.C. Size(ϕd)(mm)		Tolerance of Corner Height(m)(mm)		I.C. Size (inch)	Tolerance of I.C. Size(ϕd)(mm)		Tolerance of Corner Height(m)(mm)	
	ClassJ.K.L.M.N	ClassU	ClassM.N	ClassU		ClassJ.K.L.M.N	ClassU	ClassJ.K.L.M.N	ClassU
6.35	± 0.05	± 0.08	± 0.08	± 0.13	0.250	± 0.002	± 0.003	± 0.003	± 0.005
9.525					0.375				
12.7	± 0.08	± 0.13	± 0.13	± 0.2	0.500	± 0.003	± 0.005	± 0.005	± 0.008
15.875	± 0.1	± 0.18	± 0.15	± 0.27	0.625	± 0.004	± 0.007	± 0.006	± 0.011
19.05					0.750				
25.4	± 0.13	± 0.25	± 0.18	± 0.38	1.000	± 0.005	± 0.010	± 0.007	± 0.015
31.75	± 0.15	± 0.25	± 0.2	± 0.38	1.250	± 0.006	± 0.010	± 0.008	± 0.015
32					1.260				

Symbol	Thickness(mm)
01	1.59
02	2.38
T2	2.78
03	3.18
T3	3.97
04	4.76
05	5.56
06	6.35
07	7.94
09	9.52

Insert Shape:D					
Inscribed Circle Size		Tolerance of I.C. Size		Tolerance of Corner Height	
mm	in	mm	in	mm	in
6.35	0.250	± 0.05	± 0.002	± 0.11	± 0.004
9.525	0.375	± 0.05	± 0.002	± 0.11	± 0.004
12.7	0.500	± 0.08	± 0.003	± 0.15	± 0.006
15.875	0.625	± 0.10	± 0.004	± 0.18	± 0.007
19.05	0.750	± 0.10	± 0.004	± 0.18	± 0.007

Insert Shape:V					
Inscribed Circle Size		Tolerance of I.C. Size		Tolerance of Corner Height	
mm	in	mm	in	mm	in
6.35	0.250	± 0.05	± 0.002	± 0.15	± 0.006
9.525	0.375	± 0.05	± 0.002	± 0.15	± 0.006
12.7	0.500	± 0.08	± 0.003	± 0.20	± 0.008
15.875	0.625	± 0.10	± 0.004	± 0.27	± 0.011
19.05	0.750	± 0.10	± 0.004	± 0.27	± 0.011

⑥

04

⑥

⑦

08

⑦

⑧

-

⑧

NM2

⑧

Inscribed Circle Size
Thickness(s)
Corner Height(m)

Corner Symbol	
Symbol	Corner-Rc(mm)
00	0.03
02	0.2
04	0.4
08	0.8
12	1.2
16	1.6
20	2.0
24	2.4
28	2.8
32	3.2

Chipbreaker Symbol

Indicates the cutting properties and chipbreaker

Turning Inserts

External turning

Internal turning

Grooving & parting

Threading

Milling

Boring & drilling

Tool holder

Solid carbide end mills

Solid carbide drill & taps

Technical information

Features of Turning Inserts

Geometry Features	80° Rhombic	55° Rhombic	90° Square	60° Triangle	35° Rhombic	80° Trigon
NF stainless steel and heat resistance super alloy						
NFM medium cutting of stainless steel and mild steel						
NM semifinished of general steel and alloy steel						
NGM semifinished of general steel and alloy steel						
NR finished of general steel and alloy steel						
medium cutting of stainless steel and mild steel						
VP stainless steel and heat resistance super alloy						
UC semifinished of general steel and alloy steel						
NL stainless steel and Iron-based Alloys cutting						
None Without chipbreaker; Stable placement machining cast iron						
NK1 machining cast iron						
NK2 cast iron cutting and heavy cutting						

Turning inserts

External turning

Internal turning

Grooving & parting

Threading

Milling

Boring & drilling







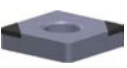

Tool holder

Solid carbide
end mills

Solid carbide
drill & taps

Technical
information

Features of Turning Inserts

Geometry Features	80° Rhombic	55° Rhombic	90° Square	60° Triangle	35° Rhombic	80° Trigon
NCBN Hardened HRC45–65						
NL aluminum alloy cutting						

Geometry Features	80° Rhombic	55° Rhombic	90° Square	60° Triangle	35° Rhombic	80° Trigon
L-F stainless steel and aluminum alloy cutting						
NF stainless steel and heat resistance super alloy						
NM light cutting of alloy steel, stainless steel and cast iron;						
NR rough cutting action of carbon steels, cast iron and alloy steels						
NL aluminum alloy cutting						
NCBN Hardened HRC45–65						
						
						
						

CNMG Rhombic80° ,with Hole

Turning Inserts (Negative)

● continuous

◐ light Interruption

⊕ Interruption

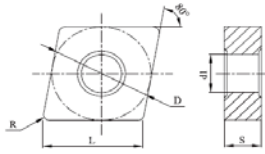

P	Steel	●	◐	⊕																
M	Stainless Steel									◐	◐	◐	◐							
K	Cast Iron																			●
N	Non-ferrous Metal													●						
S	Heat-resistant Alloy, TiAlloy													●	◐					
H	High Hardness Materials																			

Shape	OrderingCode	Dimensions(mm)					Coated-CVD					Coated-PVD		Uncoated	Cermet		Coated								
		L	D	S	d1	R	TP1115	TP1125	TP1135	TK1115	TK1125	TM1125	TM3125	TS4115	TS4125	TN9115	TP9125	TP115T	TP125T	TS7912	TH7936	TK7915	TS7911		
	CNMG120404-NF	12.90	12.70	4.76	5.16	0.40								●	○										
	CNMG120408-NF	12.90	12.70	4.76	5.16	0.80								●	○										
	CNMG120404-NFM	12.90	12.70	4.76	5.16	0.40									●										
	CNMG120408-NFM	12.90	12.70	4.76	5.16	0.80									●										
	CNMG120404-NM	12.90	12.70	4.76	5.16	0.40	○	●																	
	CNMG120408-NM	12.90	12.70	4.76	5.16	0.80	○	●																	
	CNMG120404-SF	12.90	12.70	4.76	5.16	0.40																	●		
	CNMG120408-SF	12.90	12.70	4.76	5.16	0.80																	●		
	CNMG120408-NR	12.90	12.70	4.76	5.16	0.80		●																	
	CNMG120412-NR	12.90	12.70	4.76	5.16	1.20		●																	
	CNMG160408-NR	16.10	15.87	6.35	6.35	0.80		○																	
	CNMG160612-NR	16.10	15.87	6.35	6.35	1.20		●																	
	CNMG160616-NR	16.10	15.87	6.35	6.35	1.60		○																	
	CNMG190612-NR	19.05	19.30	6.35	7.94	1.20		●																	
	CNMG120404-VP	12.90	12.70	4.76	5.16	0.40																●		●	
	CNMG120408-VP	12.90	12.70	4.76	5.16	0.80																●		●	
	CNMA120404	12.90	12.70	4.76	5.16	0.40				●															
	CNMA120408	12.90	12.70	4.76	5.16	0.80				●	●														
	CNMA120412	12.90	12.70	4.76	5.16	1.20				●	●														
	CNMA160808	16.10	15.87	6.35	6.35	0.80				●															
	CNMA160612	16.10	15.87	6.35	6.35	1.20				●															
	CNMG120404-NK1	12.90	12.70	4.76	5.16	0.40				●	●														
	CNMG120408-NK1	12.90	12.70	4.76	5.16	0.80				●	●														
	CNMG120412-NK1	12.90	12.70	4.76	5.16	1.20				●	●														
	CNMG160608-NK1	16.10	15.87	6.35	6.35	0.80				●	●														
	CNMG160612-NK1	16.10	15.87	6.35	6.35	1.20				●	●														
	CNMG120408-UC	12.90	12.70	4.76	5.16	0.80																	●		
	CNMG120412-UC	12.90	12.70	4.76	5.16	1.20																	●		

● Stock ○ Available upon Order

Turning inserts

External turning

Internal turning

Grooving & parting

Threading

Milling

Boring & drilling

Tool holder

Solid carbide end mills

Solid carbide drill & taps

Technical information

DNMG/DNMA Rhombic55° ,with Hole

Turning Inserts (Negative)

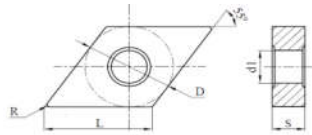

● continuous ◐ light Interruption ⊕ Interruption

P	Steel	●	◐	⊕																
M	Stainless Steel									◐	◐	◐	◐							
K	Cast Iron									●	◐									
N	Non-ferrous Metal														●					
S	Heat-resistant Alloy, TiAlloy														◐	◐				
H	High Hardness Materials																			

Shape	OrderingCode	Dimensions(mm)					Coated-CVD					Coated-PVD		Uncoated	Cermet	Coated									
		L	D	S	d1	R	TP1115	TP1125	TP1135	TK1115	TK1125	TM1125	TM3125	TS4115	TS4125	TN9115	TP9125	TP115T	TP125T	TS7912	TH7936	TK7915	TS7911		
	DNMG150404-NF	15,50	12,70	4,76	5,16	0,40								●	○										
	DNMG150408-NF	15,50	12,70	4,76	5,16	0,80								●	○										
	DNMG150404-NFM	15,50	12,70	4,76	5,16	0,40									●										
	DNMG150408-NFM	15,50	12,70	4,76	5,16	0,80									●										
	DNMG150404-NM	15,50	12,70	4,76	5,16	0,40	○	●																	
	DNMG150408-NM	15,50	12,70	4,76	5,16	0,80	○	●																	
	DNMG150604-NM	15,50	12,70	6,35	5,16	0,40	○	●																	
	DNMG150608-NM	15,50	12,70	6,35	5,16	0,80	○	●																	
	DNMG150404-VP	15,50	12,70	4,76	5,16	0,40																●		●	
	DNMG150408-VP	15,50	12,70	4,76	5,16	0,80																●		●	
	DNMG150412-VP	15,50	12,70	4,76	5,16	1,20																●		●	
	DNMG150408-NR	15,50	12,70	6,35	5,16	0,40		●																	
	DNMG150412-NR	15,50	12,70	6,35	5,16	0,80		●																	
	DNMG150608-NR	15,50	12,70	6,35	5,16	1,20		●																	
	DNMG150612-NR	15,50	12,70	4,76	5,16	0,80		○																	
	DNMG150604-NL	15,50	12,70	4,76	5,16	0,40									●	●									
	DNMG150608-NL	15,50	12,70	4,76	5,16	0,80									●	●									
	DNMA150404	15,50	12,70	4,76	5,16	0,40																			
	DNMA150408	15,50	12,70	4,76	5,16	0,80																			
	DNMA150412	15,50	12,70	4,76	5,16	1,20																			
	DNMA150608	15,50	12,70	6,35	5,16	0,80																			
	DNMA150612	15,50	12,70	6,35	5,16	1,20																			
	DNMG150404-NK1	15,50	12,70	4,76	5,16	0,40																			
	DNMG150408-NK1	15,50	12,70	4,76	5,16	0,80																			
	DNMG150412-NK1	15,50	12,70	4,76	5,16	1,20																			
	DNMG150604-NK1	15,50	12,70	6,35	5,16	0,40																			
	DNMG150608-NK1	15,50	12,70	6,35	5,16	0,80																			
	DNMG150612-NK1	15,50	12,70	6,35	5,16	1,20																			
	DNMG150408-UC	15,50	12,70	4,76	5,16	0,80																			●
	DNMG150412-UC	15,50	12,70	4,76	5,16	1,20																			●
	DNMG150608-UC	15,50	12,70	6,35	5,16	0,80																			●
DNMG150612-UC	15,50	12,70	6,35	5,16	1,20																			●	

● Stock ○ Available upon Order

Turning Inserts

External turning

Internal turning

Grooving & parting

Threading

Milling

Boring & drilling

Tool holder

Solid carbide end mills

Solid carbide drill & taps

Technical information

SNMG/SNMA Rhombic90°, with Hole

Turning Inserts (Negative)

● continuous ◐ light Interruption ⊕ Interruption

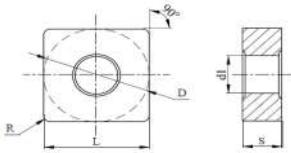

Material	TP1115	TP1125	TP1135	TK1115	TK1125	TM1125	TM3125	TS4115	TS4125	TN9115	TP9125	TP115T	TP125T	TS7912	TH7936	TK7915	TS7911
P Steel	●	◐						●	◐			●					
M Stainless Steel								●	◐			●					
K Cast Iron				●	◐												
N Non-ferrous Metal										●							
S Heat-resistant Alloy, TiAlloy								●	◐								
H High Hardness Materials																	

Shape	OrderingCode	Dimensions(mm)					Coated-CVD		Coated-PVD		Uncoated		Cermet		Coated										
		L	D	S	d1	R	TP1115	TP1125	TP1135	TK1115	TK1125	TM1125	TM3125	TS4115	TS4125	TN9115	TP9125	TP115T	TP125T	TS7912	TH7936	TK7915	TS7911		
	SNMG120404-NF	12.70	12.70	4.76	5.16	0.40								●	○										
	SNMG120408-NF	12.70	12.70	4.76	5.16	0.80								●	○										
	SNMG120404-NFM	12.70	12.70	4.76	5.16	0.40								●											
	SNMG120408-NFM	12.70	12.70	4.76	5.16	0.80								●											
	SNMG120404-NM	12.70	12.70	4.76	5.16	0.40	●																		
	SNMG120408-NM	12.70	12.70	4.76	5.16	0.80	●																		
	SNMG120412-NM	12.70	12.70	4.76	5.16	1.20	●																		
	SNMG120404-VP	12.70	12.70	4.76	5.16	0.40																●		●	
	SNMG120408-VP	12.70	12.70	4.76	5.16	0.80																●		●	
	SNMG120408-SF	12.70	12.70	4.76	5.16	0.80																	●		
	SNMG120412-SF	12.70	12.70	4.76	5.16	1.20																	●		
		15.87	15.87	6.35	6.35	0.80																			
	SNMG120408-UC	19.05	19.05	6.35	7.94	1.20																		●	
	SNMG120412-UC	19.05	19.05	6.35	7.94	1.60																		●	
	SNMG120408-NL	12.70	12.70	4.76	5.16	0.80								●	●										
	SNMG120412-NL	12.70	12.70	4.76	5.16	1.20								●	●										
	SNMA120404	12.90	12.70	4.76	5.16	0.40																			
	SNMA120408	12.90	12.70	4.76	5.16	0.80				○															
	SNMA120412	12.90	12.70	4.76	5.16	1.20				○															
	SNMG120408-NK1	12.70	12.70	4.76	5.16	0.80								●	●										
	SNMG120412-NK1	12.70	12.70	4.76	5.16	1.20								●	●										
	SNMG150608-NK1	15.87	15.87	6.35	6.35	0.80								●	○										
	SNMG150612-NK1	15.87	15.87	6.35	6.35	1.20								○	○										
	SNMG150616-NK1	15.87	15.87	6.35	6.35	1.60								○	○										
	SNMG190612-NK1	19.05	19.30	6.35	7.94	1.20								○	○										
	SNMG190616-NK1	19.05	19.30	6.35	7.94	1.60								○	○										
	SNMG120408-NK2	12.70	12.70	4.76	5.16	0.80								●	●										
	SNMG120412-NK2	12.70	12.70	4.76	5.16	1.20								●	●										

● Stock ○ Available upon Order

Turning inserts

External turning

Internal turning

Grooving & parting

Threading

Milling

Boring & drilling

Tool holder

Solid carbide end mills

Solid carbide drill & taps

Technical Information

TNMG/TNMA/TNGA Triangle 60° ,w th Hole

Turning Inserts (Negative)

● continuous

◐ light Interruption

⊕ Interrupt on

Shape	OrderingCode	Dimensions(mm)					Coated-CVD				Coated-PVD		Uncoated	Cermet	Coated										
		L	D	S	d1	R	TP1115	TP1125	TP1135	TK1115	TK1125	TM1125	TM3125	TS4115	TS4125	TN9115	TP9125	TP115T	TP125T	TS7912	TH7936	TK7915	TS7911		
	TNMG160404-NF	16.50	9.52	4.76	3.18	0.40							●	○											
	TNMG160408-NF	16.50	9.52	4.76	3.18	0.80							●	○											
	TNMG160404-NFM	16.50	9.52	4.76	3.18	0.40							●												
	TNMG160408-NFM	16.50	9.52	4.76	3.18	0.80							●												
	TNMG160404-NM	16.50	9.52	4.76	3.18	0.40	○	●									●								
	TNMG160408-NM	16.50	9.52	4.76	3.18	0.80	○	●			●						●								
	TNMG160412-NM	16.50	9.52	4.76	3.18	1.20	○	●																	
	TNMG160404-SF	16.50	9.52	4.76	3.18	0.40																		●	
	TNMG160408-SF	16.50	9.52	4.76	3.18	0.80																		●	
	TNMG160404R-VP	16.50	9.52	4.76	3.18	0.40																		●	●
	TNMG160408R-VP	16.50	9.52	4.76	3.18	0.80																		●	●
	TNMG160404L-VP	16.50	9.52	4.76	3.18	0.40																		●	●
	TNMG160408L-VP	16.50	9.52	4.76	3.18	0.80																		●	●
	TNMG160404R	16.50	9.52	4.76	3.18	0.40												●							
	TNMG160408R	16.50	9.52	4.76	3.18	0.80												●							
	TNMG160404L	16.50	9.52	4.76	3.18	0.40												●							
	TNMG160408L	16.50	9.52	4.76	3.18	0.80												●							
	TNMG160408-NL	16.50	9.52	4.76	3.18	0.80								●											
	TNMG160408-NL	16.50	9.52	4.76	3.18	1.20								●											
	TNMA160404	16.50	9.52	4.76	3.18	0.40																			
	TNMA160408	16.50	9.52	4.76	3.18	0.80								●	○										
	TNMA160412	16.50	9.52	4.76	3.18	1.20								●	○										
	TNMG160404-UC	16.50	9.52	4.76	3.18	0.40																			●
	TNMG160408-UC	16.50	9.52	4.76	3.18	0.80																			●
	TNMG160412-UC	16.50	9.52	4.76	3.18	1.20																			●
	TNMG160408-NK2	16.50	9.52	4.76	3.18	0.80																			
	TNMG160412-NK2	16.50	9.52	4.76	3.18	1.20																			

● Stock ○ Available upon Order

Turning Inserts

External turning

Internal turning

Grooving & parting

Threading

Milling

Boring & drilling

Tool holder

Solid carbide end mills

Solid carbide drill & taps

Technical information

VNMG/VNMG Rhomb c 35° ,w th Hole

Turning Inserts (Negative)

● continuous ◐ light Interruption ⊕ Interruption

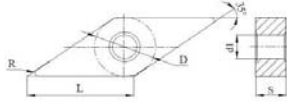

P	Steel	●	◐																	
M	Stainless Steel			●	◐															
K	Cast Iron					●	◐													
N	Non-ferrous Metal												●							
S	Heat-resistant Alloy, TiAlloy												●	◐						
H	High Hardness Materials																			

Shape	OrderingCode	Dimensions(mm)					Coated-CVD					Coated-PVD		Uncoated	Cermet		Coated								
		L	D	S	d1	R	TP1115	TP1125	TP1135	TK1115	TK1125	TM1125	TM3125	TS4115	TS4125	TN9115	TP9125	TP115T	TP125T	TS7912	TH7936	TK7915	TS7911		
	VNGG160404-NL	16.60	9.52	4.76	3.81	0.40								●	○										
	VNGG160408-NL	16.60	9.52	4.76	3.81	0.80								●	○										
	VNMG160404-NFM	16.60	9.52	4.76	3.81	0.40									●										
	VNMG160408-NFM	16.60	9.52	4.76	3.81	0.80									●										
	VNMG160404-NM	16.60	9.52	4.76	3.81	0.40	○	●										○							
	VNMG160408-NM	16.60	9.52	4.76	3.81	0.80	○	●										○							
	VNMG160412-NM	16.60	9.52	4.76	3.81	1.20	○	○																	
	VNMG160404-SF	16.60	9.52	4.76	3.81	0.40																	●		
	VNMG160408-SF	16.60	9.52	4.76	3.81	0.80																	●		
	VNMG160404-UC	16.60	9.52	4.76	3.81	0.40																		●	
	VNMG160408-UC	16.60	9.52	4.76	3.81	0.80																		●	
	VNMG160412-UC	16.60	9.52	4.76	3.81	1.20																		●	
	VNMG160404-NK2	16.60	9.52	4.76	3.81	0.40																			
	VNMG160408-NK2	16.60	9.52	4.76	3.81	0.80				●	●														
	VNMG160412-NK2	16.60	9.52	4.76	3.81	1.20				●	○														

● Stock ○ Available upon Order

Turning inserts

External turning

Internal turning

Grooving & parting

Threading

Milling

Boring & drilling

Tool holder

Solid carbide end mills

Solid carbide drill & taps

Technical information

WNMG/WNMA/WNGA

Trigon 80° ,w th Hole

Turning Inserts (Negative)

● continuous

◐ light Interruption

⊕ Interruption

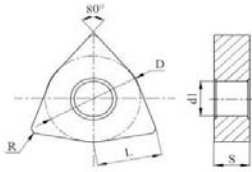

P	Steel	●	◐																	
M	Stainless Steel									●	◐									
K	Cast Iron									●	◐									
N	Non-ferrous Metal													●						
S	Heat-resistant Alloy, TiAlloy													●	◐					
H	High Hardness Materials																			

Shape	OrderingCode	Dimensions(mm)					Coated-CVD					Coated-PVD		Uncoated	Cermets		Coated								
		L	D	S	d1	R	TP1115	TP1125	TP1135	TK1115	TK1125	TM1125	TM3125	TS4115	TS4125	TN9115	TP9125	TP115T	TP125T	TS7912	TH7936	TK7915	TS7911		
	WNGG080404L-NF	8.70	12.70	4.76	5.16	0.40								●	○										
	WNGG080408L-NF	8.70	12.70	4.76	5.16	0.80								●	○										
	WNMG080404-NFM	8.70	12.70	4.76	5.16	0.40									●										
	WNMG080408-NFM	8.70	12.70	4.76	5.16	0.80									●										
	WNMG080404-NM	8.70	12.70	4.76	5.16	0.40	●																		
	WNMG080408-NM	8.70	12.70	4.76	5.16	0.80	●																		
	WNMG080404-SF	8.70	12.70	4.76	5.16	0.40																		●	
	WNMG080408-SF	8.70	12.70	4.76	5.16	0.80																		●	
	WNMG080408-VP	8.70	12.70	4.76	5.16	0.80																	●		●
	WNMG080412-VP	8.70	12.70	4.76	5.16	1.20																	●		●
	WNMG080404-NL	8.70	12.70	4.76	5.16	0.40									●	●									
	WNMG080408-NL	8.70	12.70	4.76	5.16	0.80									●	●									
	WNMA080404	8.70	12.70	4.76	5.16	0.40				●	○														
	WNMA080408	8.70	12.70	4.76	5.16	0.80				●	●														
	WNMA080412	8.70	12.70	4.76	5.16	1.20				●	●														
	WNMG080404-UC	8.70	12.70	4.76	5.16	0.40																		●	
	WNMG080408-UC	8.70	12.70	4.76	5.16	0.80																		●	
	WNMG080412-UC	8.70	12.70	4.76	5.16	1.20																		●	
	WNMG080408-NK2	8.70	12.70	4.76	5.16	0.80				●	●														
	WNMG080412-NK2	8.70	12.70	4.76	5.16	1.20				●	●														

● Stock ○ Available upon Order

Turning Inserts

External turning

Internal turning

Grooving & parting

Threading

Milling

Boring & drilling

Tool holder

Solid carbide end mills

Solid carbide drill & taps

Technical information

CNGA/CNGG

Rhomb c80° ,w th Hole

Turning Inserts (Negative)

● continuous

◐ Light Interrupt on

⊕ Interrupt on

	P	Steel																						
	M	Stainless Steel																						
	K	Cast Iron																		●	●			
	N	Non-ferrous Metal													●									
	S	Heat-resistant Alloy, T Alloy																						
	H	High Hardness Materials																		●	●			
Shape	Ordering Code	Dimensions (mm)					Coated-CVD					Coated-PVD			Uncoated	Cermets		Coated						
		L	D	S	d1	R	TP1115	TP1125	TP1135	TK1115	TK1125	TM1125	TM3125	TS4115	TS4125	TN9115	TP9125	TP115T	TP125T	TS7912	TH7936	TK7915	TS7911	
	CNGA120404-Z2	12.90	12.70	4.76	5.16	0.40														●	○			
	CNGA120408-Z2	12.90	12.70	4.76	5.16	0.80															●	○		
	CNGA120412-Z2	12.90	12.70	4.76	5.16	1.20															●	○		
	CNGG120402-NL	12.90	12.70	4.76	5.16	0.20									●									
	CNGG120404-NL	12.90	12.70	4.76	5.16	0.40									●									
	CNGG120408-NL	12.90	12.70	4.76	5.16	0.80									●									

CNGA/CNGG

Rhomb c80° ,w th Hole

Turning Inserts (Negative)

● continuous

◐ Light Interrupt on

⊕ Interrupt on

	P	Steel																						
	M	Stainless Steel																						
	K	Cast Iron																			●	●		
	N	Non-ferrous Metal														●								
	S	Heat-resistant Alloy, T Alloy																						
	H	High Hardness Materials																				●	●	
Shape	Ordering Code	Dimensions (mm)					Coated-CVD					Coated-PVD			Uncoated	Cermets		CBN	PCD					
		L	D	S	d1	R	TP1115	TP1125	TP1135	TK1115	TK1125	TM1125	TM3125	TS4115	TS4125	TN9115	TP9125	TP115T	TP125T					
	DNGA150404-Z2	12.90	12.70	4.76	5.16	0.40															●	○		
	DNGA150408-Z2	12.90	12.70	4.76	5.16	0.80															●	○		
	DNGA150412-Z2	12.90	12.70	4.76	5.16	1.20															●	○		
	DNGG150404-NL	12.90	12.70	4.76	5.16	0.40									●									
	DNGG150408-NL	12.90	12.70	4.76	5.16	0.80									●									
	DNGG150412-NL	12.90	12.70	4.76	5.16	1.20																		

● Stock ○ Available upon Order

SNGA/SNGG

Square 90° , w th Hole

Turning Inserts (Negative)

● continuous

⦿ light Interruption

⊕ Interruption

Shape	OrderingCode	Dimensions(mm)					Coated-CVD				Coated-PVD			Uncoated	Cermet	Coated									
		L	D	S	d1	R	Tp1115	TP1125	TP1135	TK1115	TK1125	TM1125	TM3125	TS4115	TS4125	TN9115	TP9125	TP115T	TP125T	TS7912	TH7936	TK7915	TS7911		
																								Steel	
	SNGA120404-Z4	12.70	12.70	4.76	5.16	0.40															●	●			
	SNGA120408-Z4	12.70	12.70	4.76	5.16	0.80																●	○		
	SNGA120412-Z4	12.70	12.70	4.76	5.16	1.20																	●	○	
	SNGG120404-NL	12.70	12.70	4.76	5.16	0.40									●										
	SNGG120408-NL	12.70	12.70	4.76	5.16	0.80									●										
	SNGG120412-NL	12.70	12.70	4.76	5.16	1.20									○										

TNGA/TNGG

Triangle 60° , with Hole

Turning Inserts (Negative)

● continuous

⦿ light Interruption

⊕ Interruption

Shape	OrderingCode	Dimensions(mm)					Coated-CVD				Coated-PVD			Uncoated	Cermet	CBN	PCD									
		L	D	S	d1	R	NP1115	NP1225	NP1135	NK1115	NK1125	NM1125	NM3125	NS4115	NS4125	NN9115	NP9125	NP115T	NP125T	NCBN115	NCBN125	NPCD115	NPCD125			
																								Steel		Stainless Steel
	TNGA160404-Z3	16.50	9.52	4.76	3.18	0.40																●	○			
	TNGA160408-Z3	16.50	9.52	4.76	3.18	0.80																	●	○		
	TNGA160412-Z3	16.50	9.52	4.76	3.18	1.20																		●	○	
	TNGG160404-NL	16.50	9.52	4.76	3.18	0.40									●											
	TNGG160408-NL	16.50	9.52	4.76	3.18	0.80									●											
	TNGG160412-NL	16.50	9.52	4.76	3.18	1.20									○											

● Stock ○ Available upon Order

- Turning Inserts
- External turning
- Internal turning
- Grooving & parting
- Threading
- Milling
- Boring & drilling
- Tool holder
- Solid carbide end mills
- Solid carbide drill & taps
- Technical information

VNGA/VNGG Rhomb c 35° ,w th Hole



Turning Inserts (Negative)

● continuous

◐ Light Interrupt on

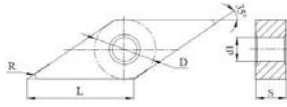
⊕ Interrupt on



Shape	Order ngCode	D mens ons(mm)					Coated-CVD					Coated-PVD		Uncoated	Cermet		Coated							
		L	D	S	d1	R	TP1115	TP125	TP1135	TK1115	TK1125	TM1125	TM3125	TS4115	TS4125	TN9115	TP9125	TP115T	TP125T	TS7912	TH7936	TK7915	TS7911	
	VNGA160404-Z2	16.60	9.52	4.76	3.81	0.40														●	○			
	VNGA160408-Z2	16.60	9.52	4.76	3.81	0.80														●	○			
	VNGG160402-NL	16.60	9.52	4.76	3.81	0.20									○									
	VNGG160404-NL	16.60	9.52	4.76	3.81	0.40									●									
	VNGG160408-NL	16.60	9.52	4.76	3.81	0.80									●									

WNGA/WNGG Tr gon 80° ,w th Hole



Turning Inserts (Negative)

● continuous

◐ Light Interrupt on

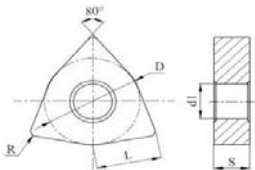
⊕ Interrupt on



Shape	Order ngCode	D mens ons(mm)					Coated-CVD					Coated-PVD		Uncoated	Cermet		Coated							
		L	D	S	d1	R	NP1115	NP125	NP1135	NK1115	NK1125	NM1125	NM3125	NS4115	NS4125	NN9115	NP9125	NP115T	NP125T	NCBN115	NCBN125	NPCD115	NPCD125	
	WNGA080404-Z3	16.60	9.52	4.76	3.18	0.40															●	○		
	WNGA080408-Z3	16.60	9.52	4.76	3.18	0.80															●	○		
	WNGA080412-Z3	16.60	9.52	4.76	3.18	1.20															●	○		
	WNGG080404-NL	16.60	9.52	4.76	3.18	0.40									●									
	WNGG080408-NL	16.60	9.52	4.76	3.18	0.80									●									
	WNGG080412-NL	16.60	9.52	4.76	3.18	1.20									○									

● Stock ○ Available upon Order

Turning inserts

External turning

Internal turning

Grooving & parting

Threading

Milling

Boring & drilling

Tool holder

Solid carbide end mills

Solid carbide drill & taps

Technical information

CCMT/CCGW/CCGT

Rhomb c 80° , w th Hole

Turning Inserts (Negative)

● continuous ◐ light Interruption ⊕ Interruption

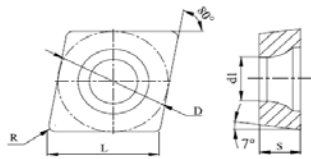

Shape	OrderingCode	Dimensions(mm)					Coated-CVD					Coated-PVD		Uncoated	Cermet	Coated									
		L	D	S	d1	R	TP1115	TP1125	TP1135	TK1115	TK1125	TM1125	TM3125	T S4115	T S4125	TN9115	TP9125	TP115T	TP125T	TS7912	TH7936	TK7915	TS7911		
																								P	M
	CCGT030102L-F	3.5	3.5	1.4	1.9	0.2	●	●																	
	CCGT030104L-F	3.5	3.5	1.4	1.9	0.4																			
	CCGT040102L-F	4.3	4.3	1.8	2.3	0.2																			
	CCGT040104L-F	4.3	4.3	1.8	2.3	0.4																			
	CCGT060602L-F	6.35	6.35	2.38	2.8	0.2																			
	CCGT060604L-F	6.35	6.35	2.38	2.8	0.4																			
	CCGT09T302L-F	9.525	9.525	3.97	4.4	0.2																			
	CCGT09T304L-F	9.525	9.525	3.97	4.4	0.4																			
	CCMT060204-NF	6.5	6.35	2.38	2.8	0.4																			
	CCMT060208-NF	6.5	6.35	2.38	2.8	0.8																			
	CCMT09T304-NF	9.7	9.52	3.97	4.4	0.4																			
	CCMT09T308-NF	9.7	9.52	3.97	4.4	0.8																			
	CCMT120404-NF	12.9	12.7	4.76	5.56	0.4									○										
	CCMT120408-NF	12.9	12.7	4.76	5.56	0.8									○										
	CCMT060204-NM	6.5	6.35	2.38	2.8	0.4	●	○																	
	CCMT060208-NM	6.5	6.35	2.38	2.8	0.8	●	○																	
	CCMT09T304-NM	9.7	9.52	3.97	4.4	0.4	●	○																	
	CCMT09T308-NM	9.7	9.52	3.97	4.4	0.8	●	○																	
	CCMT120404-NM	12.9	12.7	4.76	5.56	0.4	●	○																	
	CCMT120408-NM	12.9	12.7	4.76	5.56	0.4	●	○																	
	CCMT060204-VP	6.5	6.35	3.38	2.8	0.4																●		●	
	CCMT060208-VP	6.5	6.35	3.97	2.8	0.8																●		●	
	CCMT09T304-VP	9.7	9.52	3.97	4.4	0.4																●		●	
	CCMT09T308-VP	9.7	9.52	3.97	4.4	0.8																●		●	
	CCMT120404-VP	12.9	12.7	4.76	5.56	0.4																●		●	
	CCMT120408-NR	12.9	12.7	4.76	5.56	0.4																●		●	
	CCGW060202-Z2	6.5	6.35	2.38	2.8	0.2																●	○		
	CCGW060204-Z2	6.5	6.35	2.38	2.8	0.4																●	○		
	CCGW09T304-Z2	9.7	9.52	3.97	4.4	0.4																●	○		
	CCGW09T308-Z2	9.7	9.52	3.97	4.4	0.8																●	○		
	CCGT060202 -UC	6.5	6.35	2.38	2.8	0.2																	●		
	CCGT060204 -UC	6.5	6.35	2.38	2.8	0.4																	●		
	CCGT09T304 -UC	9.7	9.52	3.97	4.4	0.4																	●		
	CCGT09T308 -UC	9.7	9.52	3.97	4.4	0.8																	●		
	CCMT 060204 SF	6.5	6.35	2.38	2.8	0.4																	●		
	CCMT 060208 SF	6.5	6.35	2.38	2.8	0.8																	●		
	CCMT 09T304 SF	9.7	9.52	3.97	4.4	0.4																	●		
	CCMT 09T308 SF	9.7	9.52	3.97	4.4	0.8																	●		
	CCMT 120404 SF	12.9	12.7	4.76	5.56	0.4																	●		
	CCMT 120408 SF	12.9	12.7	4.76	5.56	0.8																	●		

● Stock ○ Available upon Order

CCGT

Rhomb c 80° ,w th Hole

Turning Inserts (Negative)

● continuous ◐ Light Interrupt on ⊕ Interrupt on

		P Steel																					
		M Stainless Steel																					
		K Cast Iron																					
		N Non-ferrous Metal																					
		S Heat-resistant Alloy, T Alloy													●								
		H High Hardness Materials																					
Shape	Ordering Code	Dimensions (mm)					Coated-CVD					Coated-PVD				Uncoated		Cermets		Coated			
		L	D	S	d1	R	TP1115	TP1125	TP1135	TK1115	TK1125	TM1125	TM3125	TS4115	TS4125	TN9115	TP9125	TP115T	TP125T	TS7912	TH7936	TK7915	TS7911
	CCGT060202-NL	6.5	6.35	2.38	2.8	0.2									●								
	CCGT060204-NL	6.5	6.35	2.38	2.8	0.4									●								
	CCGT060208-NL	6.5	6.35	2.38	2.8	0.8									○								
	CCGT09T302-NL	9.7	9.52	3.97	4.4	0.2									●								
	CCGT09T304-NL	9.7	9.52	3.97	4.4	0.4									●								
	CCGT09T308-NL	9.7	9.52	3.97	4.4	0.8									●								
	CCGT120402-NL	12.9	12.7	4.76	5.56	0.4									○								
	CCGT120404-NL	12.9	12.7	4.76	5.56	0.4									●								
	CCGT120408-NL	12.9	12.7	4.76	5.56	0.4									●								

SCMT/SCGT

Rhomb c 80° ,w th Hole

Turning Inserts (Negative)

● continuous ◐ Light Interrupt on ⊕ Interrupt on

		P Steel																			●	●	
		M Stainless Steel																					●
		K Cast Iron																				●	
		N Non-ferrous Metal																					●
		S Heat-resistant Alloy, T Alloy																					
		H High Hardness Materials																					
Shape	Ordering Code	Dimensions (mm)					Coated-CVD					Coated-PVD				Uncoated		Cermets		CBN		PCD	
		L	D	S	d1	R	NP1115	NP1225	NP1135	NK1115	NK1125	NM1125	NM3125	NS4115	NS4125	NN9115	NP9125	NP115T	NP125T	NCBN115	NCBN125	NPCD115	NPCD125
	SCMT09T304-NM	9.52	9.52	3.97	4.4	0.4	●	○		●								○					
	SCMT09T308-NM	9.52	9.52	3.97	4.4	0.8	●	○		●								○					
	SCMT120404-NM	12.7	12.7	4.76	5.56	0.4	●	○		●								○					
	SCMT120408-NM	12.7	12.7	4.76	5.56	0.8	●	○		●								○					
	SCMT09T304-NR	9.52	9.52	3.97	4.4	0.4	○	●															
	SCMT09T308-NR	9.52	9.52	3.97	4.4	0.8	○	●															
	SCMT120404-NR	12.7	12.7	4.76	5.56	0.4	○	●															
	SCMT120408-NR	12.7	12.7	4.76	5.56	0.8	○	●															
	SCGT09T304-NL	9.52	9.52	3.97	4.4	0.4																	
	SCGT09T308-NL	9.52	9.52	3.97	4.4	0.8																	
	SCGT120404-NL	12.7	12.7	4.76	5.56	0.4																	
	SCGT120408-NL	12.7	12.7	4.76	5.56	0.8																	

● Stock ○ Available upon Order

Turning inserts

External turning

Internal turning

Grooving & parting

Threading

Milling

Boring & drilling

Tool holder

Solid carbide end mills

Solid carbide drill & taps

Technical information

DCGT/DCMT Rhombic 55° ,with Hole

Turning Inserts (Negative)

● continuous ◐ light Interruption ⊕ Interruption

Shape	OrderingCode	Dimensions(mm)					Coated-CVD				Coated-PVD				Uncoated		Cermet		Coated				
		L	D	S	d1	R	TP1115	TP1125	TP1135	TK1115	TK1125	TM1125	TM3125	TS4115	TS4125	TN9115	TP9125	TP115T	TP125T	TS7912	TH7936	TK7915	TS7911
							○	○	○	○	○	○	○	○	○	○	○	○	○	○	○	○	○
	DCMT070202-SF	7.80	6.35	2.38	2.80	0.20																	●
	DCMT070204-SF	7.80	6.35	2.38	2.80	0.40																	●
	DCMT11T304-SF	11.60	9.25	3.97	4.40	0.40																	●
	DCMT11T308-SF	11.60	9.25	3.97	4.40	0.80																	●
	DCGT070202-NF	7.80	6.35	2.38	2.80	0.20								●									
	DCGT070204-NF	7.80	6.35	2.38	2.80	0.40								●									
	DCGT11T302-NF	11.60	9.25	3.97	4.40	0.20								●									
	DCGT11T304-NF	11.60	9.25	3.97	4.40	0.40								●									
	DCMT070202-	7.80	6.35	2.38	2.80	0.20	○	○															
	DCMT070204-	7.80	6.35	2.38	2.80	0.40	●	○	●														
	DCMT11T304-	11.60	9.25	3.97	4.40	0.40	●	○	●														
	DCMT11T308-	11.60	9.25	3.97	4.40	0.80	●	○	●														
	DCGW070202-Z2	7.80	6.35	2.38	2.80	0.20														●	○		
	DCGW070204-Z2	11.60	9.25	3.97	4.40	0.20														●	○		
	DCGW11T304-Z2	11.60	9.25	3.97	4.40	0.40														●	○		
	DCGW11T308-Z2	11.60	9.25	3.97	4.40	0.80														●	○		
	DCGT070202L-Z1	7.80	6.35	2.38	2.80	0.20																●	○
	DCGT070204L-Z1	7.80	6.35	2.38	2.80	0.40																●	○
	DCGT11T302L-Z1	11.60	9.25	3.97	4.40	0.20																●	○
	DCGT11T304L-Z1	11.60	9.25	3.97	4.40	0.80																●	○
	DCMT070202-VP	7.80	6.35	2.38	2.80	0.20															●		●
	DCMT070204-VP	7.80	6.35	2.38	2.80	0.40															●		●
	DCMT11T304-VP	11.60	9.25	3.97	4.40	0.40															●		●
	DCMT11T308-VP	11.60	9.25	3.97	4.40	0.80															●		●
	DCGT070204-NL	7.80	6.35	2.38	2.80	0.40									●								
	DCGT11T302-NL	11.60	9.25	3.97	4.40	0.20									●								
	DCGT11T304-NL	11.60	9.25	3.97	4.40	0.40									●								
	DCGT11T308-NL	11.60	9.25	3.97	4.40	0.80									●								

● Stock ○ Available upon Order

- Turning Inserts
- External turning
- Internal turning
- Grooving & parting
- Threading
- Milling
- Boring & drilling
- Tool holder
- Solid carbide end mills
- Solid carbide drill & taps
- Technical information

TPGT/TCMT/TCGT/TCGW

Rhomb c 55° ,w th Hole

Turning Inserts (Negative)

● continuous

◐ light Interruption

⊕ Interruption

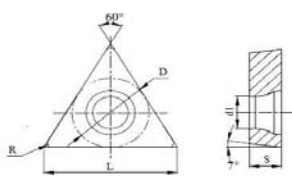

P	Steel	●	◐																	
M	Stainless Steel										◐	●								
K	Cast Iron																			●
N	Non-ferrous Metal																			●
S	Heat-resistant Alloy, TiAlloy																			●
H	High Hardness Materials																			◐

Shape	OrderingCode	Dimensions(mm)					Coated-CVD					Coated-PVD		Uncoated		Cermert		Coated						
		L	D	S	d1	R	TP1115	TP1125	TP1135	TK1115	TK1125	TM1125	TM3125	TS4115	TS4125	TN9115	TP9125	TP115T	TP125T	TS7912	TH7936	TK7915	TS7911	
	TBGT060102L-F	6	3.97	1.59	2.3	0.2																		
	TBGT060104L-F	6	3.97	1.59	2.3	0.4																		
	TPGH080202L-F	8	4.76	2.38	2.3	0.2																		
	TPGH080204L-F	8	4.76	2.38	2.3	0.4																		
	TPGH090202L-F	9	5.56	2.38	3	0.2																		
	TPGH090204L-F	9	5.56	2.38	3	0.4																		
	TPGH110302L-F	11	6.35	3.18	3.3	0.2																		
	TPGH110304L-F	11	6.35	3.18	3.3	0.4																		
	TCMT090204-NF	9.6	5.56	2.38	2.5	0.4																		
	TCMT110204-NF	11	6.35	2.38	2.8	0.4																		
	TCMT110208-NF	11	6.35	2.38	2.8	0.8																		
	TCMT16T304-NF	16.5	9.52	3.97	4.4	0.4																		
	TCMT16T308-NF	16.5	9.52	3.97	4.4	0.8																		
	TCMT090204-NP	9.6	5.56	2.38	2.5	0.4	●	○		●														
	TCMT110204-NM	11	6.35	2.38	2.8	0.4	●	○		●														
	TCMT110208-NM	11	6.35	2.38	2.8	0.8	●	○		●														
	TCGW110204-Z3	11	6.35	2.38	2.8	0.4																●	○	
	TCGW110208-Z3	11	6.35	2.38	2.8	0.8																●	○	
	TCGW16T304-Z3	16.5	9.52	3.97	4.4	0.4																●	○	
	TCGW16T308-Z3	16.5	9.52	3.97	4.4	0.8																●	○	
	TCMT090204-VP	11	6.35	3.18	3.4	0.2																		●
	TCMT110204-VP	11	6.35	3.18	3.4	0.4																		●
	TCMT110208-VP	16.5	9.52	3.18	4.4	0.2																		●
	TCMT16T304-VP	16.5	9.52	3.18	4.4	0.4																		●
	TCMT16T308-VP	16.5	9.52	3.18	4.4	0.8																		●
	TCMT16T308-VP	16.5	9.52	3.18	4.4	0.8																		●
	TCGT090202-NL	9.6	5.56	2.38	2.5	0.2																		
	TCGT090204-NL	9.6	5.56	2.38	2.5	0.4																		
	TCGT110202-NL	11	6.35	2.38	2.8	0.2																		
	TCGT110204-NL	11	6.35	2.38	2.8	0.4																		
	TCGT110208-NL	11	6.35	2.38	2.8	0.8																		
	TCGT16T302-NL	16.5	9.52	3.97	4.4	0.2																		
	TCGT16T304-NL	16.5	9.52	3.97	4.4	0.4																		
	TCGT16T308-NL	16.5	9.52	3.97	4.4	0.8																		
	TCMW16T304	16.5	9.52	3.97	4.4	0.4																		○
	TCMW16T308	16.5	9.52	3.97	4.4	0.8																		○

● Stock ○ Available upon Order

Turning inserts

External turning

Internal turning

Grooving & parting

Threading

Milling

Boring & drilling

Tool holder

Solid carbide end mills

Solid carbide drill & taps

Technical information

VBGT/VBMT/VCMT/VBGX/VCGX Rhomb c 35° ,w th Hole

Turning Inserts (Negative)

● continuous

◐ light Interruption

⊕ Interruption

Shape	OrderingCode	Dimensions(mm)					Coated-CVD				Coated-PVD		Uncoated	Cermet		Coated									
		L	D	S	d1	R	TP1115	TP1125	TP1135	TK1115	TK1125	TM1125	TM3125	TS4115	TS4125	TN9115	TP9125	TP115T	TP125T	TS7912	TH7936	TK7915	TS7911		
	VBMT070202 -VP	7.6	4.35	2.18	2.8	0.2																			
	VBMT070204 -VP	7.6	4.35	2.18	2.8	0.4																			
	VBMT110304 -VP	11.6	6.35	3.18	2.8	0.8																			
	VBMT110308 -VP	11.6	6.35	3.18	2.8	0.2																			
	VBMT160404-NF	16.6	9.52	4.76	4.4	0.4																			
	VBMT160408-NF	16.6	9.52	4.76	4.4	0.8																			
	VBMT110302-NF	11.6	6.35	3.18	2.8	0.2																			
	VBMT110304-NF	11.6	6.35	3.18	2.8	0.4																			
	VBMT110308-NF	11.6	6.35	3.18	2.8	0.8																			
	VBMT160302-NF	16.6	9.52	4.76	4.4	0.2																			
	VBMT160304-NF	16.6	9.52	4.76	4.4	0.4																			
	VBMT160308-NF	16.6	9.52	4.76	4.4	0.8																			
	VCMT160302-NF	16.6	9.52	4.76	4.4	0.2																			
	VCMT160304-NF	16.6	9.52	4.76	4.4	0.4																			
	VCMT160308-NF	16.6	9.52	4.76	4.4	0.8																			
		VBMT160404-NM	16.6	9.52	4.76	4.4	0.4	●	○		●														
VBMT160408-NM		16.6	9.52	4.76	4.4	0.8	●	○		●															
VCMT110304-NM		11.6	6.35	3.18	2.8	0.4	●	○		●															
VCMT110308-NM		11.6	6.35	3.18	2.8	0.8	●	○		●															
VCMT160404-NM		16.6	9.52	4.76	4.4	0.4	●	○		●															
VCMT160408-NM		16.6	9.52	4.76	4.4	0.8	●	○		●															
	VCGT110302-NL	11.6	6.35	3.18	2.8	0.2									○										
	VCGT110304-NL	11.6	6.35	3.18	2.8	0.4									●										
	VCGT110308-NL	11.6	6.35	3.18	2.8	0.8									●										
	VCGT160402-NL	16.6	9.52	4.76	4.4	0.2									○										
	VCGT160404-NL	16.6	9.52	4.76	4.4	0.4									●										
	VCGT160408-NL	16.6	9.52	4.76	4.4	0.8									●										
	VCGW110302-Z2	11.6	6.35	3.18	2.8	0.2																●	○		
	VCGW110304-Z2	11.6	6.35	3.18	2.8	0.4																●	○		
	VCGW110308-Z2	11.6	6.35	3.18	2.8	0.8																●	○		
	VCGW160402-Z2	16.6	9.52	4.76	4.4	0.2																●	○		
	VCGW160404-Z2	16.6	9.52	4.76	4.4	0.4																●	○		
	VCGT160408-Z2	16.6	9.52	4.76	4.4	0.8																●	○		
	VCGT110302-Z1	11.6	6.35	3.18	2.8	0.2																	●	○	
	VCGT110304-Z1	11.6	6.35	3.18	2.8	0.4																	●	○	
	VCGT110308-Z1	11.6	6.35	3.18	2.8	0.8																	●	○	
	VCGT160402-Z1	16.6	9.52	4.76	4.4	0.2																	●	○	
	VCGT160404-Z1	16.6	9.52	4.76	4.4	0.4																	●	○	
	VCGT160408-Z1	16.6	9.52	4.76	4.4	0.8																	●	○	

● Stock ○ Available upon Order

Turning Inserts

External turning

Internal turning

Grooving & parting

Threading

Milling

Boring & drilling

Tool holder

Solid carbide end mills

Solid carbide drill & taps

Technical information

WBG

Rhomb c 55° , with Hole

Turning Inserts (Negative)

● continuous ● light Interruption ⊕ Interruption

Shape	OrderingCode	Dimensions(mm)					Coated-CVD					Coated-PVD		Uncoated		Cermet		Coated						
		L	D	S	d1	R	TP1115	TP1125	TP1135	TK1115	TK1125	TM1125	TM3125	TS4115	TS4125	TN9115	TP9125	TP115T	TP125T	TS7912	TH7936	TK7915	TS7911	
	WBG060102L-F	3.97	3.97	1.59	2.3	0.2								●				●						
	WBG060104L-F	3.97	3.97	1.59	2.3	0.4								●				●						
	WBG080202L-F	4.76	4.76	2.38	2.3	0.2								●				●						
	WBG080204L-F	4.76	4.76	2.38	2.3	0.4								●				●						

KNUX

Rhombic 55° , with Hole

Turning Inserts (Negative)

● continuous ● light Interruption ⊕ Interruption

Shape	OrderingCode	Dimensions(mm)					Coated-CVD					Coated-PVD		Uncoated		Cermet		CBN		PCD				
		L	D	S	d1	R	NP1115	NP1225	NP1135	NK1115	NK1125	NM1125	NM3125	NS4115	NS4125	NN9115	NF9125	NP115T	NP125T	NCBN115	NCBN125	NPCD115	NPCD125	
	KNUX160405L11	16	16.15	9.525	4.76	0.5		●																
	KNUX160410L11	16	16.15	9.525	4.76	1.0		●																
	KNUX160405L12	16	16.15	9.525	4.76	0.5		●																
	KNUX160410L12	16	16.15	9.525	4.76	1.0		●																
	KNUX160405R11	16	16.15	9.525	4.76	0.5		●																
	KNUX160410R11	16	16.15	9.525	4.76	1.0		●																
	KNUX160405R12	16	16.15	9.525	4.76	0.5		●																
	KNUX160410R12	16	16.15	9.525	4.76	1.0		●																

● Stock ○ Available upon Order

Turning inserts

External turning

Internal turning

Grooving & parting

Threading

Milling

Boring & drilling

Tool holder

Solid carbide end mills

Solid carbide drill & taps

Technical information

RCMT/RCGT



Rhomb c 55° ,w th Hole

Turning Inserts (Negative)

● continuous

◐ light Interruption

⊕ Interruption

Shape	OrderingCode	Dimensions(mm)					Coated-CVD					Coated-PVD		Uncoated	Cermet		Coated							
		L	D	S	d1	R	TP1115	TP1125	TP1135	TK1115	TK1125	TM1125	TM3125	TS4115	TS4125	TN9115	TP9125	TP115T	TP125T	TS7912	TH7936	TK7915	TS7911	
	RCMTX0803MO	8.0	3.18	3.4			●							○										
	RCMT1003MO	10	3.18	3.6			●							○										
	RCMT1204MO	12	4.76	4.4			●							○										
	RCMT1606MO	16	6.35	5.5			●							○										
	RCMT2006MO	20	6.35	6.5			●							○										
	RCMT2507MO	25	7.94	7.2			●							○										
	RCMT3209MO	32	9.525	9.5			●							○										
	RCGT0602MO-NL	6.0	6.0	2.38	2.5	3								●										
	RCGT0803MO-NL	8.0	8.0	3.18	3.4	4								●										
	RCGT1003MO-NL	10	10	3.18	4.4	5								●										
	RCGT1204MO-NL	12	12	4.76	5.5	6								●										

● Stock ○ Available upon Order

Turning Inserts

External turning

Internal turning

Grooving & parting

Threading

Milling

Boring & drilling

Tool holder

Solid carbide end mills

Solid carbide drill & taps

Technical information

EXTERNAL TURNING TOOLS



Toolholder Clamping System

D-Holder Type

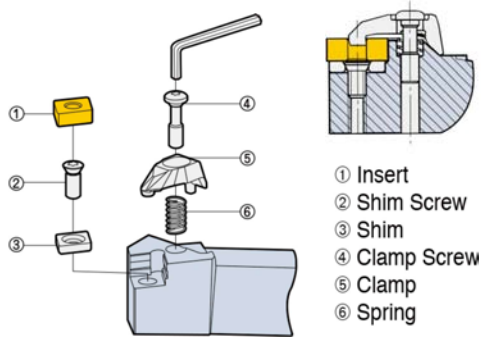

M-Multi Lock Type

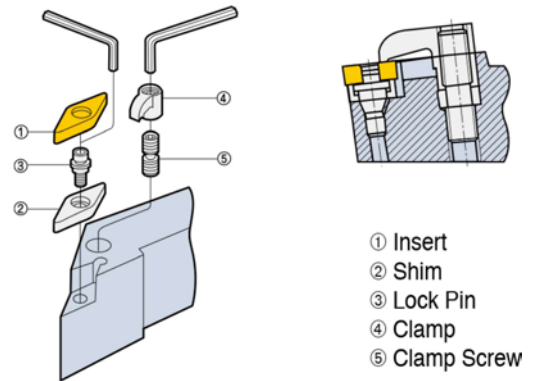

S-Screw Clamp Type

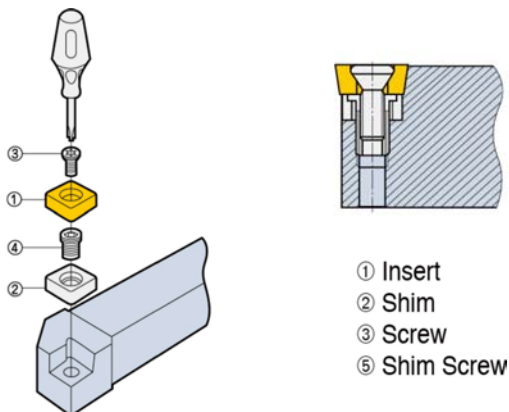

W-Wedge Clamp Type

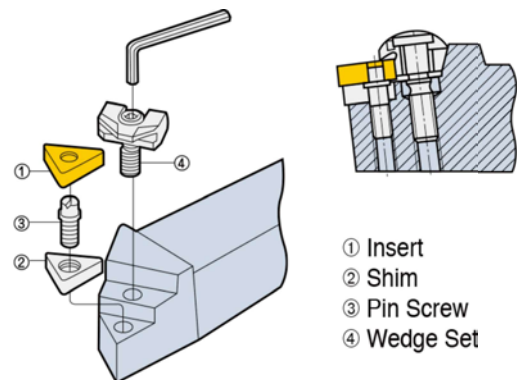

B-Bao Clamp Holder

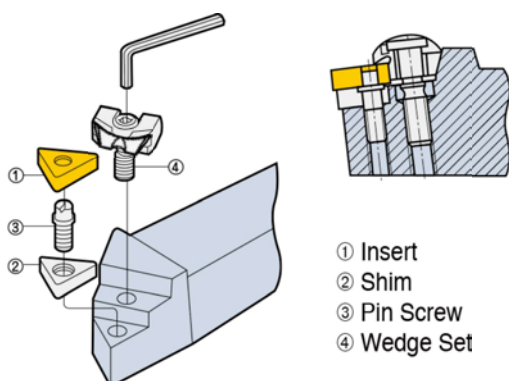

P-Hook Lever Type

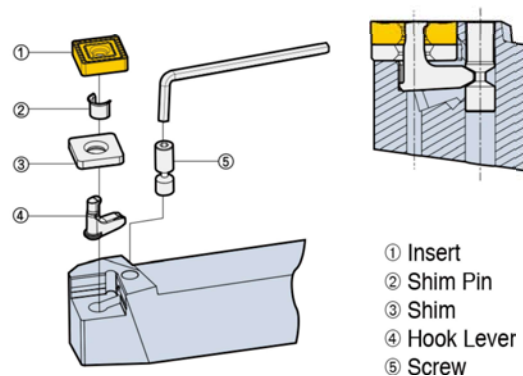

Turning inserts

External turning

Internal turning

Grooving & parting

Threading

Milling

Boring & drilling

Tool holder

Solid carbide end mills

Solid carbide drill & taps

Technical information

External Turning Toolholders Identification System

M

C

L

N

R





①

















②

③







④





⑤

Method of Holding		
	Double Clamp Type	D
	Wedge Lock Type Heavy Cutting Double Clamp Type	M
	Lever Lock Type	P
	Wedge lock holding	B
	Screw-on Type	S

Cutting Edge Angle		
A	90°	
B	75°	
D	45°	
E	60°	
F	91°	
G	90°	
U	93°	
K	75°	
L	95°	
N	63°	
P	62.5°	
Q	108°	
S	45°	
T	60°	
V	72.5°	
Z	93°	

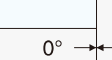
Hand of Tool	
R	Right Hand
L	Left Hand
N	Left Right

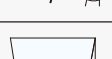
Insert Shape		
C		80° Rhombic
D		55° Rhombic
R		Round
S		Square
T		Triangle
V		35° Rhombic
W		Trigon

Insert Clearance	
N	
P	
C	
B	
E	
D	

Turning inserts

External turning

Internal turning

Grooving & parting

Threading

Milling

Boring & drilling

Tool holder

Solid carbide end mills

Solid carbide drill & taps

Technical information

External Turning Toolholders Identification System

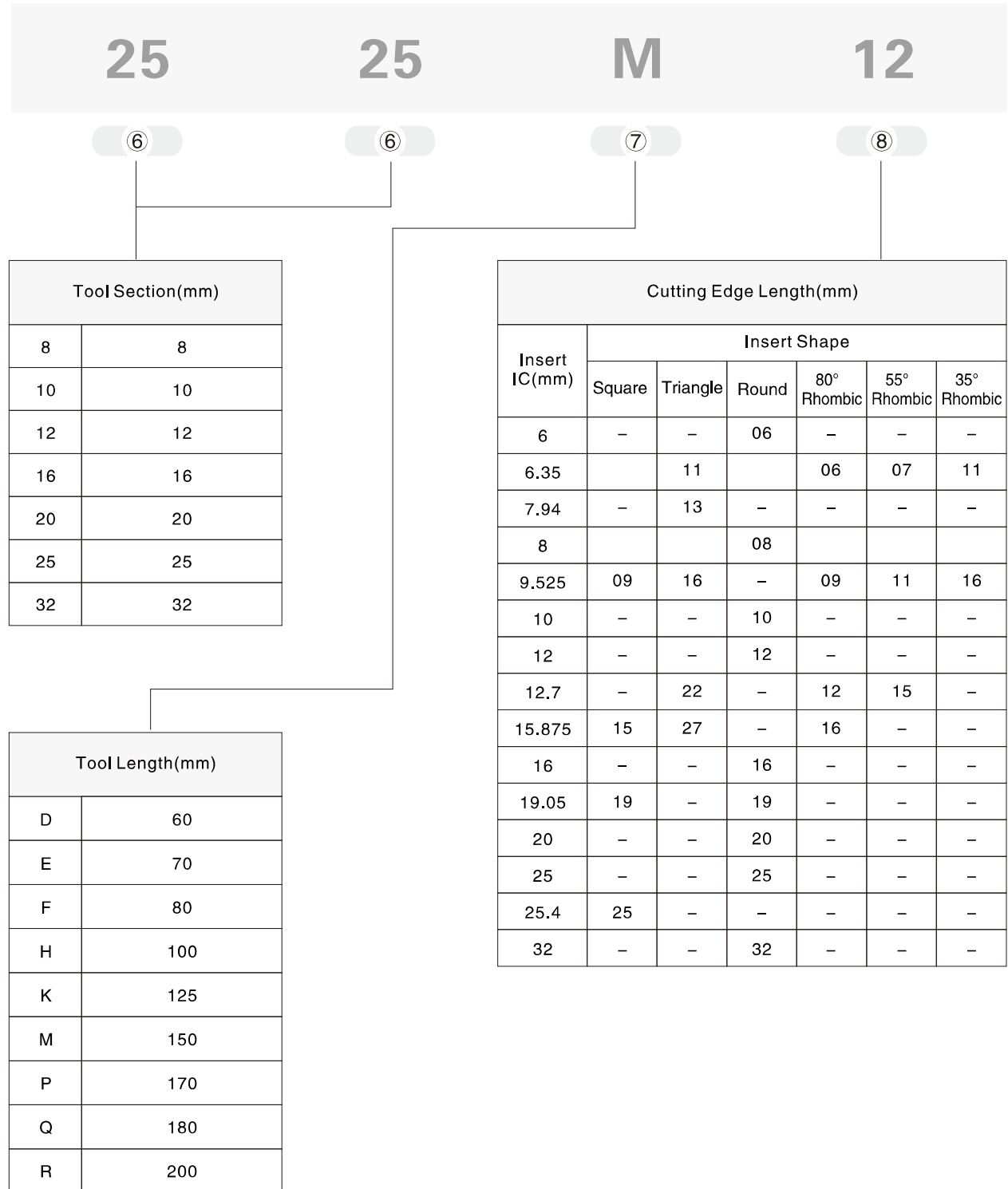

Turning inserts

External turning

Internal turning

Grooving & parting

Threading

Milling

Boring & drilling

Tool holder

Solid carbide end mills

Solid carbide drill & taps

Technical information

MCLNR/L



P039

PCLNR/L



P039

DCLNR/L



P040

BCLNR/L



P040

MCBNR/L



P041

PCBNR/L



P041

MCKNR/L



P042

PCKNR/L



P042

MCMNN / MCMNN-100



P043

MDJNR/L



P043

DDJNR/L



P044

PDJNR/L



P044

MDQNR/L



P045

DDQNR/L



P045

PDPNN



P046

DDPNN



P046

MSBNR/L



P047

PSBNR/L



P047

MSKNR/L



P048

PSKNR/L



P048

MSDNN/PSDNN



P049

MSSNR/L



P050

PSSNR/L



P050

MTJNR/L



P051

PTJNR/L



P051

DTJNR/L



P052

WTJNR/L



P052

BTJNR/L



P053

MTQNR/L



P053

DTQNR/L



P054

WTQNR/L



P054

MTFNR/L



P055

PTFNR/L



P055

MTGNR/L



P056

PTGNR/L



P056

MTENN/PTENN



P057

WTENN



P058

MVJNR/L



P058

DVJNR/L



P059

BVJNR/L



P059

MVQNR/L



P060

DVQNR/L



P060

MVUNR/L



P061

DVUNR/L



P061

MVVNN/DVVNN



P062

MWLNR/L



P063

PWLNR/L



P063

DWLNR/L



P064

Turning inserts

External turning

Internal turning

Grooving & parting

Threading

Milling

Boring & drilling

Tool holder

Solid carbide end mills

Solid carbide drill & taps

Technical information

Turning inserts

External turning

Internal turning

Grooving & parting

Threading

Milling

Boring & drilling

Tool holder

Solid carbide end mills

Solid carbide drill & taps

Technical information

BWLNR/L



P064

SCLCR/L



P065

SCKCR/L



P065

SCBCR/L



P066

SCMCN



P066

SDJCR/L



P067

SDQCR/L



P067

SDFCR/L



P068

SDACR/L



P068

SDNCN



P069

SSBCR/L



P069

SSKCR/L



P070

SSSCR/L



P070

STGCR/L



P071

STFCR/L



P071

SVJCR/L



P072

SVQCR/L



P072

SVJBR/L



P073

SVQBR/L



P073

SVUCR/L



P074

SVVCN



P074

SRACR/L CRACR/L



P075

SRGCR/L



P076

SRDCN/CRDCN



P077

MCLNR/L

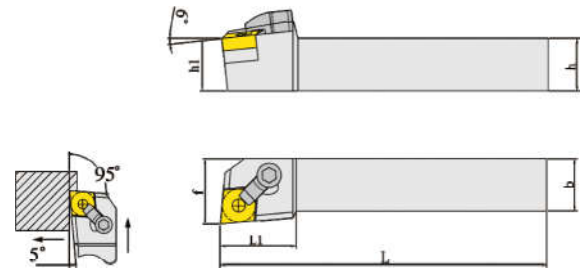

Ordering Code	Stock		Dimensions(mm)						Insert	Pad	Pin	Pressing plate	Screw	Wrench
	R	L	h	b	L	L1	h1	f						
MCLNR/L1616H12	●	●	16	16	100	34	16	20	CN**1204	CN-M1204	MXD0617	MYB1814	ST0625	L2.5 L3.0
MCLNR/L2020K12	●	●	20	20	125	34	20	25						
MCLNR/L2525M12	●	●	25	25	150	34	25	32						
MCLNR/L3232P12	●	●	32	32	170	40	32	40						

PCLNR/L

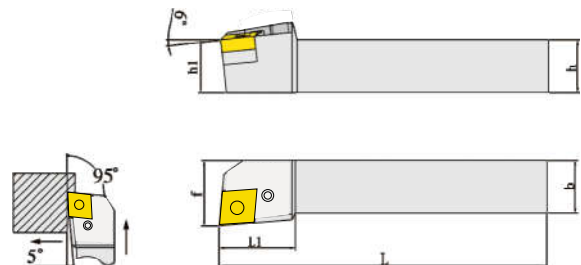

Ordering Code	Stock		Dimensions(mm)						Insert	Pad	Level	Shim	Screw	Wrench
	R	L	h	b	L	L1	h1	f						
PCLNR/L1616H12	○	○	16	16	100	28	16	20	CN**1204	CN-P1203	GGX0514	DPX0606	NLJ0820	L3.0
PCLNR/L2020K12	●	●	20	20	125	28	20	25						
PCLNR/L2525M12	●	●	25	25	150	28	25	32						
PCLNR/L3232P12	●	●	32	32	170	30	32	40						
PCLNR/L2525M16	●	●	25	25	150	33	25	32	CN**1606	CN-P1604	GGX0617	DPX0808	NLJ0821	L4.0
PCLNR/L3232P16	●	●	32	32	170	33	32	40						
PCLNR/L3232P19	●	●	32	32	170	36	32	40	CN**1906	CN-P1904	GGX0820	DPX0909	NLJ1027	
PCLNR/L4040S19	●	●	40	40	250	40	40	50						
PCLNR/L4040S25	●	●	40	40	250	47	40	50	CN**2509	CN-P2506	GGX0925	DPX1312	NLJ1237	
PCLNR/L5050T25	●	●	50	50	300	47	50	60						

● Stock ○ Available upon Order

Turning inserts

External turning

Internal turning

Grooving & parting

Threading

Milling

Boring & drilling

Tool holder

Solid carbide end mills

Solid carbide drill & taps

Technical information

Turning inserts

External turning

Internal turning

Grooving & parting

Threading

Milling

Boring & drilling

Tool holder

Solid carbide end mills

Solid carbide drill & taps

Technical information

DCLNR/L



Ordering Code	Stock		Dimensions(mm)						Insert	Pad	Pin	Pressing plate	Screw	Spring	Wrench
	R	L	h	b	L	L1	h1	f							
DCLNR/L1616H12	○	○	16	16	100	32	16	20	CN**1204	CN-D1204	DXD0614	DYB2214	DGD0520	DTN0814	L4.0
DCLNR/L2020K12	●	●	20	20	125	32	20	25							
DCLNR/L2525M12	●	●	25	25	150	32	25	32							
DCLNR/L3232P12	●	●	32	32	170	35	32	40							

BCLNR/L

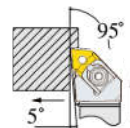

Ordering Code	Stock		Dimensions(mm)						Insert	Pad	Pin	Pressing plate	Screw	Spring	Wrench
	R	L	h	b	L	L1	h1	f							
BCLNR/L2020K12	●	●	20	20	125	32	20	25	CN**1204	CN-B1204	CTM6-S	BC12	BCS08	CR07	L3.0 L4.0
BCLNR/L2525M12	●	●	25	25	150	32	25	32							
BCLNR/L3232P12	●	●	32	32	170	35	32	40							

● Stock ○ Available upon Order

External turning tools

MCBNR/L

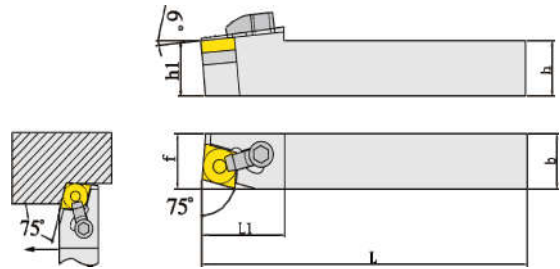

Ordering Code	Stock		Dimensions(mm)						Insert	Pad	Pin	Pressing plate	Screw	Wrench
	R	L	h	b	L	L1	h1	f						
MCBNR/L1616H12			16	16	100	34	16	20	CN**1204	CN-M1204	MXD0617	MYB1814	ST0625	L2.5 L3.0
MCBNR/L2020K12	●	●	20	20	125	34	20	25						
MCBNR/L2525M12	●	●	25	25	150	34	25	32						
MCBNR/L3232P12	●	●	32	32	170	40	32	40						

PCBNR/L

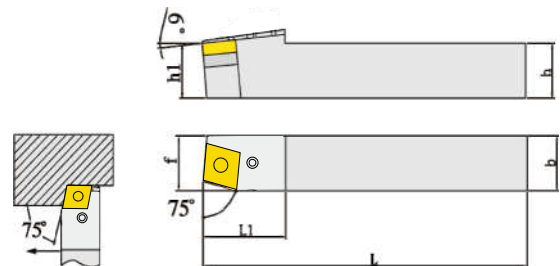

Ordering Code	Stock		Dimensions(mm)						Insert	Pad	Level	Shim	Screw	Wrench
	R	L	h	b	L	L1	h1	f						
PCBNR/L1616H12			16	16	100	28	16	20	CN**1204	CN-P1203	GGX0514	DPX0606	NLJ0820	L3.0
PCBNR/L2020K12	●	●	20	20	125	28	20	25						
PCBNR/L2525M12	●	●	25	25	150	28	25	32						
PCBNR/L3232P12	●	●	32	32	170	30	32	40						
PCBNR/L2525M16	●	●	25	25	150	33	25	32	CN**1606	CN-P1604	GGX0617	DPX0808	NLJ0821	L4.0
PCBNR/L3232P16	●	●	32	32	170	33	32	40						
PCBNR/L3232P19	●	●	32	32	170	36	32	40	CN**1906	CN-P1904	GGX0820	DPX0909	NLJ1027	
PCBNR/L4040S19	●	●	40	40	250	40	40	50						
PCBNR/L4040S25	●	●	40	40	250	47	40	50	CN**2509	CN-P2506	GGX0925	DPX1312	NLJ1237	
PCBNR/L5050T25	●	●	50	50	300	47	50	60						

● Stock ○ Available upon Order

Turning inserts

External turning

Internal turning

Grooving & parting

Threading

Milling

Boring & drilling

Tool holder

Solid carbide end mills

Solid carbide drill & taps

Technical information

Turning inserts

External turning

Internal turning

Grooving & parting

Threading

Milling

Boring & drilling

Tool holder

Solid carbide end mills

Solid carbide drill & taps

Technical information

MCKNR/L

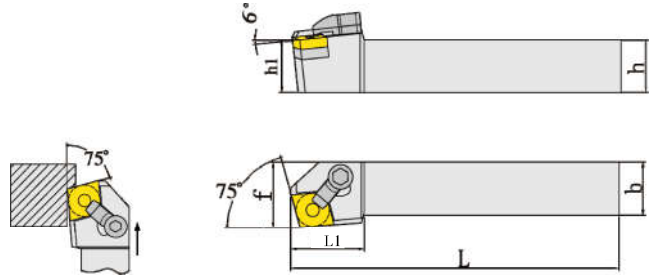

Ordering Code	Stock		Dimensions(mm)						Insert	Pad	Pin	Pressingplate	Screw	Wrench
	R	L	h	b	L	L1	h1	f						
MCKNR/L1616H12	○	○	16	16	100	32	16	20	CN**1204	CN-M1204	MXD0617	MYB1814	ST0625	L2.5 L3.0
MCKNR/L2020K12	●	●	20	20	125	32	20	25						
MCKNR/L2525M12	●	●	25	25	150	32	25	32						
MCKNR/L3232P12	●	●	32	32	170	35	32	40						

PCKNR/L

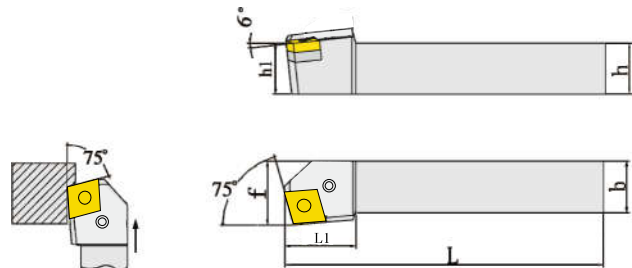

Ordering Code	Stock		Dimensions(mm)						Insert	Pad	Level	Shim	Screw	Wrench
	R	L	h	b	L	L1	h1	f						
PCKNR/L1616H12	○	○	16	16	100	28	16	20	CN**1204	CN-P1203	GGX0514	DPX0606	NLJ0820	L3.0
PCKNR/L2020K12	●	●	20	20	125	28	20	25						
PCKNR/L2525M12	●	●	25	25	150	28	25	32						
PCKNR/L3232P12	●	●	32	32	170	30	32	40						
PCKNR/L2525M16	●	●	25	25	150	33	25	32	CN**1606	CN-P1604	GGX0617	DPX0808	NLJ0821	L4.0
PCKNR/L3232P16	●	●	32	32	170	33	32	40						
PCKNR/L3232P19	●	●	32	32	170	36	32	40	CN**1906	CN-P1904	GGX0820	DPX0909	NLJ1027	
PCKNR/L4040S19	●	●	40	40	250	40	40	50						
PCKNR/L4040S25	●	●	40	40	250	47	40	50	CN**2509	CN-P2506	GGX0925	DPX1312	NLJ1237	L5.0
PCKNR/L5050T25	●	●	50	50	300	47	50	60						

● Stock ○ Available upon Order

MCMNN / MCMNN-100

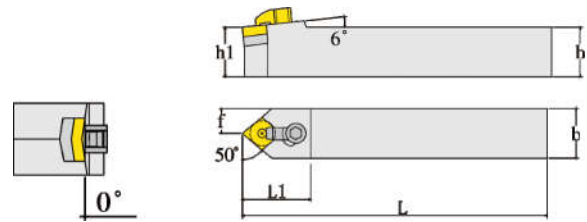

Ordering Code	Stock		Dimensions(mm)					Insert	Pad	Pin	Pressingplate	Screw	Wrench	
	○	●	h	b	L	L1	h1							f
MCMNN1616H12	○		16	16	100	35	16	8	CN**1204	CN-M1204	MXD0617	MYB1814	ST0625	L2.5 L3.0
MCMNN2020K12	●		20	20	125	35	20	10						
MCMNN2525M12	●		25	25	150	35	25	12.5						
MCMNN3232P12	●		32	32	170	35	32	40						
MCMNN2020K12-100	●		20	20	125	35	20	10						
MCMNN2525M12-100	●		25	25	150	35	25	12.5						
MCMNN3232P12-100	●		32	32	170	35	32	40						

MDJNR/L

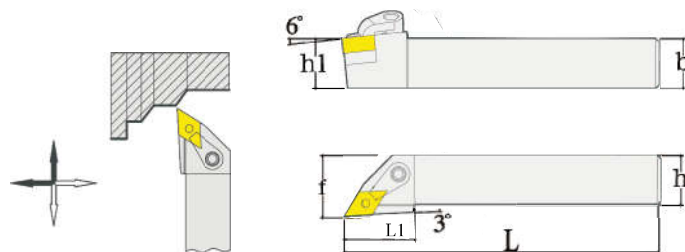

Ordering Code	Stock		Dimensions(mm)					Insert	Pad	Pin	Pressingplate	Screw	Wrench	
	R	L	h	b	L	L1	h1							f
MDJNR/L1616H11	●	●	16	16	100	32	16	20	DN**1104	DN-M1104	MXD0513	MYB2214	ST0625	L2.0 L3.0
MDJNR/L2020K11	●	●	20	20	125	32	20	25						
MDJNR/L2525M11	●	●	25	25	150	32	25	32						
MDJNR/L2020K1504	●	●	20	20	125	38	20	25	DN**1504	DN-M1506	MXD0619	MYB2214	ST0626	L2.5 L3.0
MDJNR/L2525M1504	●	●	25	25	150	38	25	32						
MDJNR/L3232P1504	●	●	32	32	170	38	32	40	DN**1506	DN-M1504	MXD0619	MYB2214	ST0626	L2.5 L3.0
MDJNR/L2020K1506	●	●	20	20	125	28	20	25						
MDJNR/L2525M1506	●	●	25	25	150	38	25	32						
MDJNR/L3232P1506	●	●	32	32	170	38	32	40						

● Stock ○ Available upon Order

Turning inserts

External turning

Internal turning

Grooving & parting

Threading

Milling

Boring & drilling

Tool holder

Solid carbide end mills

Solid carbide drill & taps

Technical information

Turning inserts

External turning

Internal turning

Grooving & parting

Threading

Milling

Boring & drilling

Tool holder

Solid carbide end mills

Solid carbide drill & taps

Technical information

DDJNR/L

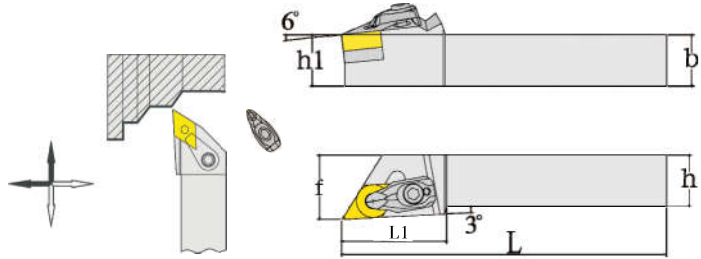

Ordering Code	Stock		Dimensions(mm)						Insert	Pad	Pin	Pressing plate	Screw	Spring	Wrench
	R	L	h	b	L	L1	h1	f							
DDJNR/L1616H11	○	○	16	16	100	32	16	20	DN**1104	DN-D1103	DXD0512	DYB2313	DGD0520	DTN0814	L4.0
DDJNR/L2020K11	○	○	20	20	125	32	20	25							
DDJNR/L2525M11	○	○	25	25	150	32	25	32							
DDJNR/L2020K1504	●	●	20	20	125	38	20	25	DN**1504	DN-D1506	DXD0614	DYB2514	DGD0520	DTN0814	L4.0
DDJNR/L2525M1504	●	●	25	25	150	38	25	32							
DDJNR/L3232P1504	●	●	32	32	170	38	32	40							
DDJNR/L2020K1506	●	●	20	20	125	38	20	25	DN**1506	DN-D1504	DXD0614	DYB2515	DGD0520	DTN0814	L4.0
DDJNR/L2525M1506	●	●	25	25	150	38	25	32							
DDJNR/L3232P1506	●	●	32	32	170	38	32	40							

PDJNR/L

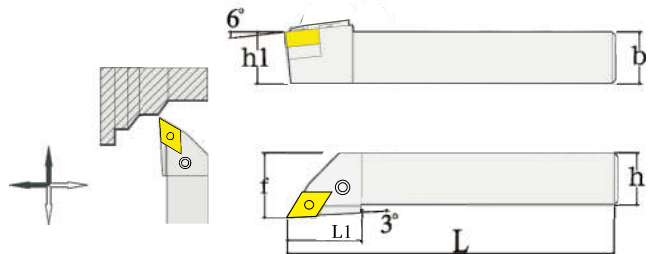

Ordering Code	Stock		Dimensions(mm)						Insert	Pad	Level	Shim	Screw	Wrench
	R	L	h	b	L	L1	h1	f						
PDJNR/L1616H11	●	●	16	16	100	32	16	20	DN**1104	DN-P1103	GGX0312	DPX0505	NLJ0618	L3.0
PDJNR/L2020K11	●	●	20	20	125	32	20	25						
PDJNR/L2525M11	●	●	25	25	150	32	25	32						
PDJNR/L2020K1504	●	●	20	20	125	38	20	25	DN**1504	DN-P1503	GGX0514	DPX0606	NLJ0820	L3.0
PDJNR/L2525M1504	●	●	25	25	150	38	25	32						
PDJNR/L3232P1504	●	●	32	32	170	38	32	40						
PDJNR/L2020K1506	●	●	20	20	125	28	20	25	DN**1506	DN-P1503	GGX0514D	DPX0606	NLJ0821	L3.0
PDJNR/L2525M1506	●	●	25	25	150	38	25	32						
PDJNR/L3232P1506	●	●	32	32	170	38	32	40						

● Stock ○ Available upon Order

MDQNR/L

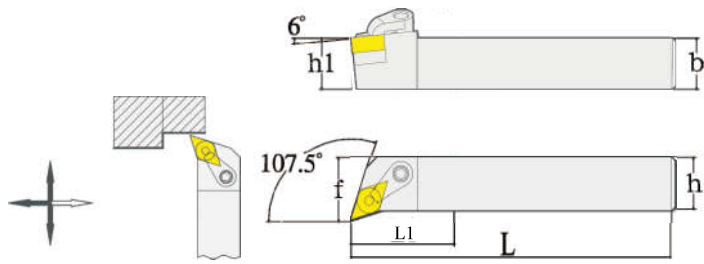

Ordering Code	Stock		Dimensions(mm)						Insert	Pad	Pin	Pressingplate	Screw	Wrench
	R	L	h	b	L	L1	h1	f						
MDQNR/L1616H11	○	○	16	16	100	32	16	20	DN**1104	DN-M1104	MXD0513	MYB2214	ST0625	L2.0 L3.0
MDQNR/L2020K11	○	○	20	20	125	32	20	25						
MDQNR/L2525M11	○	○	25	25	150	32	25	32						
MDQNR/L2020K1504	●	●	20	20	125	38	20	25	DN**1504	DN-M1506	MXD0619	MYB2214	ST0626	L2.5 L3.0
MDQNR/L2525M1504	●	●	25	25	150	38	25	32						
MDQNR/L3232P1504	●	●	32	32	170	38	32	40						
MDQNR/L2020K1506	●	●	20	20	125	28	20	25	DN**1506	DN-M1504	MXD0619	MYB2214	ST0626	L2.5 L3.0
MDQNR/L2525M1506	●	●	25	25	150	38	25	32						
MDQNR/L3232P1506	●	●	32	32	170	38	32	40						

DDQNR/L

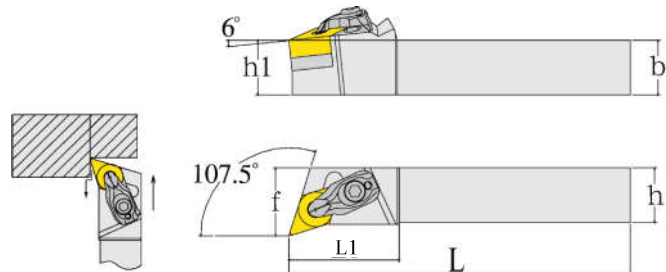

Ordering Code	Stock		Dimensions(mm)						Insert	Pad	Pin	Pressingplate	Screw	Spring	Wrench
	R	L	h	b	L	L1	h1	f							
DDQNR/L1616H11	○	○	16	16	100	32	16	20	DN**1104	DN-D1103	DXD0512	DYB2313	DGD0520	DTN0814	L4.0
DDQNR/L2020K11	○	○	20	20	125	32	20	25							
DDQNR/L2525M11	○	○	25	25	150	32	25	32							
DDQNR/L2020K1504	●	●	20	20	125	38	20	25	DN**1504	DN-D1506	DXD0614	DYB2514	DGD0520	DTN0814	L4.0
DDQNR/L2525M1504	●	●	25	25	150	38	25	32							
DDQNR/L3232P1504	●	●	32	32	170	38	32	40							
DDQNR/L2020K1506	●	●	20	20	125	38	20	25	DN**1506	DN-D1504	DXD0614	DYB2515	DGD0520	DTN0814	L4.0
DDQNR/L2525M1506	●	●	25	25	150	38	25	32							
DDQNR/L3232P1506	●	●	32	32	170	38	32	40							

● Stock ○ Available upon Order

Turning inserts

External turning

Internal turning

Grooving & parting

Threading

Milling

Boring & drilling

Tool holder

Solid carbide end mills

Solid carbide drill & taps

Technical information

Turning inserts

External turning

Internal turning

Grooving & parting

Threading

Milling

Boring & drilling

Tool holder

Solid carbide end mills

Solid carbide drill & taps

Technical information

PDPNN

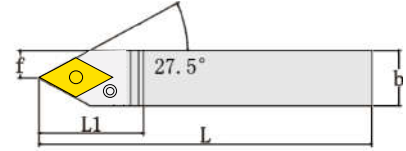
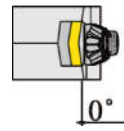

Ordering Code	Stock	Dimensions(mm)						Insert	Pad	Level	Shim	Screw	Wrench
		h	b	L	L1	h1	f						
PDPNN1616H11	○	16	16	100	32	16	20	DN**1104	DN-P1103	GGX0312	DPX0505	NLJ0618	L3.0
PDPNN2020K11	○	20	20	125	32	20	25						
PDPNN2525M11	○	25	25	150	32	25	32						
PDPNN2020K1504	●	20	20	125	38	20	25	DN**1504	DN-P1503	GGX0514	DPX0606	NLJ0820	L3.0
PDPNN2525M1504	●	25	25	150	38	25	32						
PDPNN3232P1504	●	32	32	170	38	32	40						
PDPNN2020K1506	●	20	20	125	28	20	25	DN**1506	DN-P1503	GGX0514D	DPX0606	NLJ0821	L3.0
PDPNN2525M1506	●	25	25	150	38	25	32						
PDPNN3232P1506	●	32	32	170	38	32	40						

DDPNN

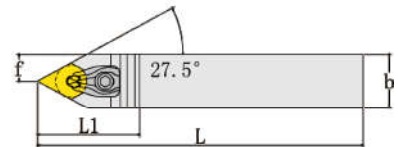
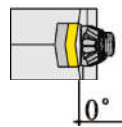

Ordering Code	Stock		Dimensions(mm)						Insert	Pad	Pin	Pressingplate	Screw	Spring	Wrench
	R	L	h	b	L	L1	h1	f							
DDPNN1616H11	●	●	16	16	100	32	16	20	DN**1104	DN-D1103	DXD0512	DYB2313	DGD0520	DTN0814	L4.0
DDPNN2020K11	●	●	20	20	125	32	20	25							
DDPNN2525M11	●	●	25	25	150	32	25	32							
DDPNN2020K1504	●	●	20	20	125	38	20	25	DN**1504	DN-D1506	DXD0614	DYB2514	DGD0520	DTN0814	L4.0
DDPNN2525M1504	●	●	25	25	150	38	25	32							
DDPNN3232P1504	●	●	32	32	170	38	32	40							
DDPNN2020K1506	●	●	20	20	125	38	20	25	DN**1506	DN-D1504	DXD0614	BYB2514	DGD0520	DTN0814	L4.0
DDPNN2525M1506	●	●	25	25	150	38	25	32							
DDPNN3232P1506	●	●	32	32	170	38	32	40							

● Stock ○ Available upon Order

MSBNR/L

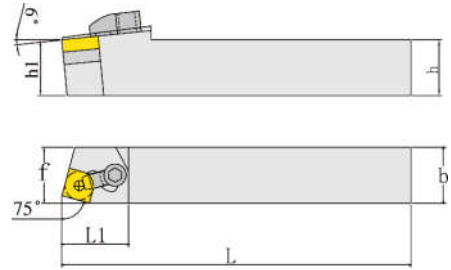
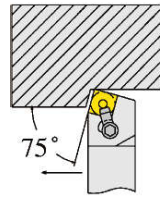

Ordering Code	Stock		Dimensions(mm)						Insert	Pad	Pin	Pressingplate	Screw	Wrench
	R	L	h	b	L	L1	h1	f						
MSBNR/L1616H12			16	16	100	34	16	20	SN**1204	SN-M1204	MXD0617	MYB1814	ST0625	L2.5 L3.0
MSBNR/L2020K12	●	●	20	20	125	34	20	25						
MSBNR/L2525M12	●	●	25	25	150	34	25	32						
MSBNR/L3232P12	●	●	32	32	170	40	32	40						

PSBNR/L

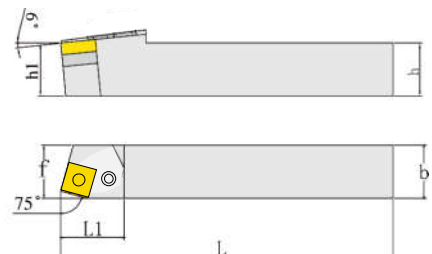
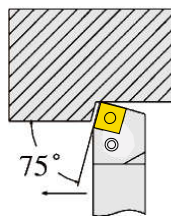

Ordering Code	Stock		Dimensions(mm)						Insert	Pad	Level	Shim	Screw	Wrench
	R	L	h	b	L	L1	h1	f						
PSBNR/L1616H12			16	16	100	28	16	20	SN**1204	SN-P1203	GGX0514	DPX0606	NLJ0820	L3.0
PSBNR/L2020K12	●	●	20	20	125	28	20	25						
PSBNR/L2525M12	●	●	25	25	150	28	25	32						
PSBNR/L3232P12	●	●	32	32	170	30	32	40						
PSBNR/L2525M15	●	●	25	25	150	33	25	32	SN**1506	SN-P1504	GGX0617	DPX0808	NLJ0821	L4.0
PSBNR/L3232P15	●	●	32	32	170	33	32	40						
PSBNR/L3232P19	●	●	32	32	170	36	32	40	SN**1906	SN-P1904	GGX0820	DPX0909	NLJ1027	
PSBNR/L4040S19	●	●	40	40	250	40	40	50						
PSBNR/L4040S25	●	●	40	40	250	47	40	50	SN**2509	SN-P2506	GGX0925	DPX1312	NLJ1237	
PSBNR/L5050T25	●	●	50	50	300	47	50	60						

● Stock ○ Available upon Order

Turning inserts

External turning

Internal turning

Grooving & parting

Threading

Milling

Boring & drilling

Tool holder

Solid carbide end mills

Solid carbide drill & taps

Technical information

Turning inserts

External turning

Internal turning

Grooving & parting

Threading

Milling

Boring & drilling

Tool holder

Solid carbide end mills

Solid carbide drill & taps

Technical information

MSKNR/L

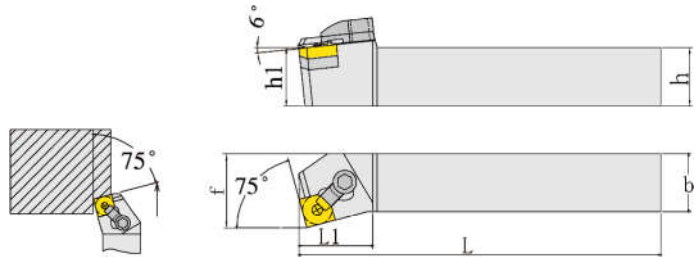

Ordering Code	Stock		Dimensions(mm)						Insert	Pad	Pin	Pressingplate	Screw	Wrench
	R	L	h	b	L	L1	h1	f						
MSKNR/L1616H12			16	16	100	34	16	20	SN**1204	SN-M1204	MXD0617	MYB1814	ST0625	L2.5 L3.0
MSKNR/L2020K12	●	●	20	20	125	34	20	25						
MSKNR/L2525M12	●	●	25	25	150	34	25	32						
MSKNR/L3232P12	●	●	32	32	170	40	32	40						

PSKNR/L

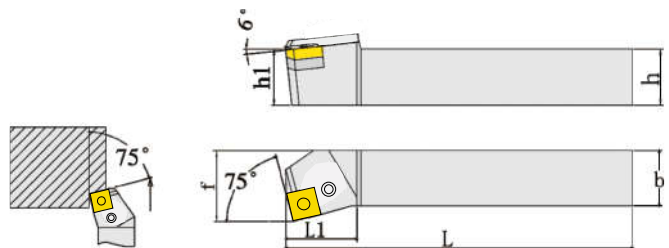

Ordering Code	Stock		Dimensions(mm)						Insert	Pad	Level	Shim	Screw	Wrench
	R	L	h	b	L	L1	h1	f						
PSKNR/L1616H12			16	16	100	28	16	20	SN**1204	SN-P1203	GGX0514	DPX0606	NLJ0820	L3.0
PSKNR/L2020K12	●	●	20	20	125	28	20	25						
PSKNR/L2525M12	●	●	25	25	150	28	25	32						
PSKNR/L3232P12	●	●	32	32	170	30	32	40						
PSKNR/L2525M15	●	●	25	25	150	33	25	32	SN**1506	SN-P1504	GGX0617	DPX0808	NLJ0821	L4.0
PSKNR/L3232P15	●	●	32	32	170	33	32	40						
PSKNR/L3232P19	●	●	32	32	170	36	32	40	SN**1906	SN-P1904	GGX0820	DPX0909	NLJ1027	
PSKNR/L4040S19	●	●	40	40	250	40	40	50						
PSKNR/L4040S25	●	●	40	40	250	47	40	50	SN**2509	SN-P2506	GGX0925	DPX1312	NLJ1237	L5.0
PSKNR/L5050T25	●	●	50	50	300	47	50	60						

● Stock ○ Available upon Order

MSDNN

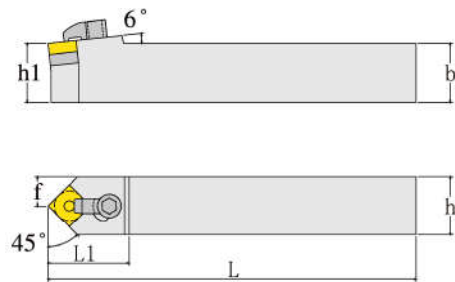
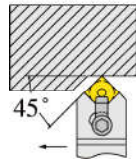

Ordering Code	Stock	Dimensions(mm)						Insert	Pad	Pin	Pressingplate	Screw	Wrench
		h	b	L	L1	h1	f						
MSDNN1616H12	○	16	16	100	34	16	20	SN**1204	SN-M1204	MXD0617	MYB1814	ST0625	L2.5 L3.0
MSDNN2020K12	●	20	20	125	34	20	25						
MSDNN2525M12	●	25	25	150	34	25	32						
MSDNN3232P12	●	32	32	170	40	32	40						

PSDNN

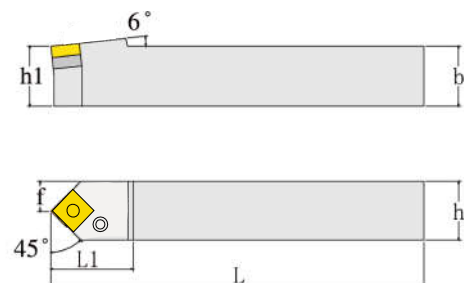
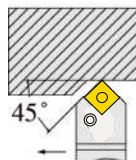

Ordering Code	Stock	Dimensions(mm)						Insert	Pad	Level	Shim	Screw	Wrench
		h	b	L	L1	h1	f						
PSDNN2020K12	●	20	20	125	28	20	25	SN**1204	SN-P1203	GGX0514	DPX0606	NLJ0820	L3.0
PSDNN2525M12	●	25	25	150	28	25	32						
PSDNN3232P12	●	32	32	170	30	32	40						
PSDNN2525M15	●	25	25	150	33	25	32	SN**1506	SN-P1504	GGX0617	DPX0808	NLJ0821	L4.0
PSDNN3232P15	●	32	32	170	33	32	40						
PSDNN3232P19	●	32	32	170	36	32	40	SN**1906	SN-P1904	GGX0820	DPX0909	NLJ1027	L5.0
PSDNN4040S19	●	40	40	250	40	40	50						
PSDNN4040S25	●	40	40	250	47	40	50	SN**2509	SN-P2506	GGX0925	DPX1312	NLJ1237	L5.0
PSDNN5050T25	●	50	50	300	47	50	60						

● Stock ○ Available upon Order

Turning inserts

External turning

Internal turning

Grooving & parting

Threading

Milling

Boring & drilling

Tool holder

Solid carbide end mills

Solid carbide drill & taps

Technical information

Turning inserts

External turning

Internal turning

Grooving & parting

Threading

Milling

Boring & drilling

Tool holder

Solid carbide end mills

Solid carbide drill & taps

Technical information

MSSNR/L

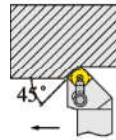

Ordering Code	Stock		Dimensions(mm)						Insert	Pad	Pin	Pressingplate	Screw	Wrench
	R	L	h	b	L	L1	h1	f						
MSSNR/L1616H12	○	○	16	16	100	34	16	20	SN**1204	SN-M1204	MXD0617	MYB1814	ST0625	L2.5 L3.0
MSSNR/L2020K12	●	●	20	20	125	34	20	25						
MSSNR/L2525M12	●	●	25	25	150	34	25	32						
MSSNR/L3232P12	●	●	32	32	170	40	32	40						

PSSNR/L

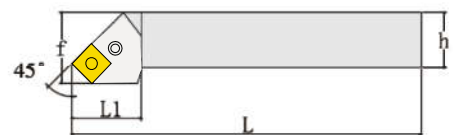
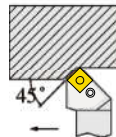

Ordering Code	Stock		Dimensions(mm)						Insert	Pad	Level	Shim	Screw	Wrench
	R	L	h	b	L	L1	h1	f						
PSSNR/L1616H12	○	○	16	16	100	28	16	20	SN**1204	SN-P1203	GGX0514	DPX0606	NLJ0820	L3.0
PSSNR/L2020K12	●	●	20	20	125	28	20	25						
PSSNR/L2525M12	●	●	25	25	150	28	25	32						
PSSNR/L3232P12	●	●	32	32	170	30	32	40						
PSSNR/L2525M15	●	●	25	25	150	33	25	32	SN**1506	SN-P1504	GGX0617	DPX0808	NLJ0821	L4.0
PSSNR/L3232P15	●	●	32	32	170	33	32	40						
PSSNR/L3232P19	●	●	32	32	170	36	32	40	SN**1906	SN-P1904	GGX0820	DPX0909	NLJ1027	
PSSNR/L4040S19	●	●	40	40	250	40	40	50						
PSSNR/L4040S25	●	●	40	40	250	47	40	50	SN**2509	SN-P2506	GGX0925	DPX1312	NLJ1237	L5.0
PSSNR/L5050T25	●	●	50	50	300	47	50	60						

● Stock ○ Available upon Order

MTJNR/L

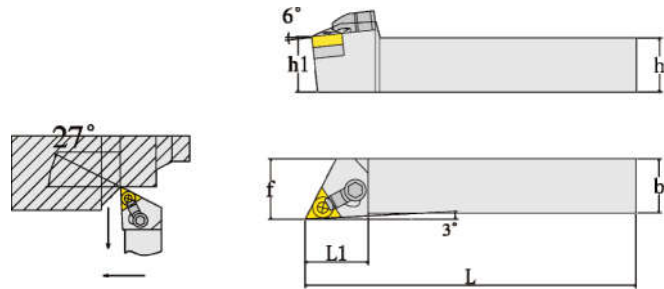

Ordering Code	Stock		Dimensions(mm)						Insert	Pad	Pin	Pressingplate	Screw	Wrench
	R	L	h	b	L	L1	h1	f						
MTJNR/L1616H16	●	●	16	16	100	30	16	20	TN**1604	TN-M1603	MXD0513	MYB1814	ST0625	L2.0 L3.0
MTJNR/L2020K16	●	●	20	20	125	33	20	25						
MTJNR/L2525M16	●	●	25	25	150	33	25	32						
MTJNR/L3232P16	●	●	32	32	170	37	32	40						

PTJNR/L

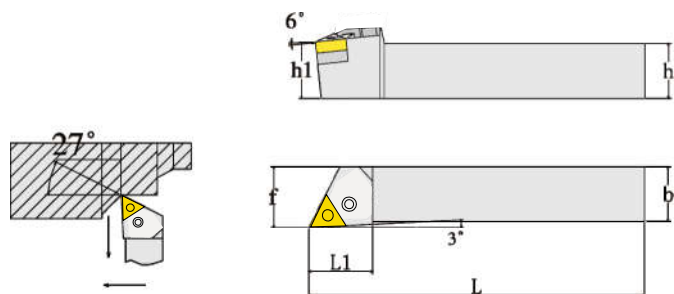

Ordering Code	Stock		Dimensions(mm)						Insert	Pad	Level	Shim	Screw	Wrench
	R	L	h	b	L	L1	h1	f						
PTJNR/L1616H16	○	○	16	16	100	22	16	20	TN**1604	TN-P1603	GGX0310	DPX0505	NLJ0618	L3.0
PTJNR/L2020K16	●	●	20	20	125	22	20	25						
PTJNR/L2525M16	●	●	25	25	150	28	25	32						
PTJNR/L3232P16	●	●	32	32	170	32	32	40						

● Stock ○ Available upon Order

Turning inserts

External turning

Internal turning

Grooving & parting

Threading

Milling

Boring & drilling

Tool holder

Solid carbide end mills

Solid carbide drill & taps

Technical information

Turning inserts

External turning

Internal turning

Grooving & parting

Threading

Milling

Boring & drilling

Tool holder

Solid carbide end mills

Solid carbide drill & taps

Technical information

DTJNR/L

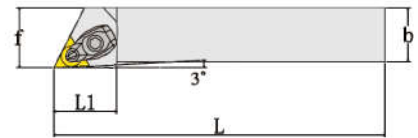
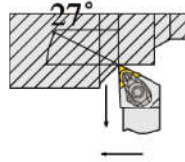

Ordering Code	Stock		Dimensions(mm)						Insert	Pad	Pin	Pressingplate	Screw	Spring	Wrench
	R	L	h	b	L	L1	h1	f							
DTJNR/L1616H16	○	○	16	16	100	32	16	20	TN**1604	TN-D1603	DXD0512	DYB2313	DGD0520	DTN0814	L4.0
DTJNR/L2020K16	●	●	20	20	125	32	20	25							
DTJNR/L2525M16	●	●	25	25	150	32	25	32							
DTJNR/L3232P16	●	●	32	32	170	35	32	40							

WTJNR/L

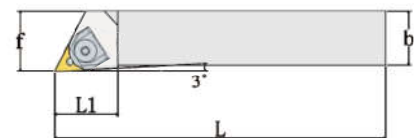
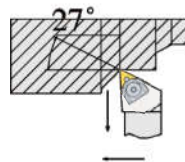

Ordering Code	Stock		Dimensions(mm)						Insert	Pad	Pin	Pressingplate	Screw	Spring	Wrench
	R	L	h	b	L	L1	h1	f							
WTJNR/L1616H16	○	○	16	16	100	32	16	20	TN**1604	TN-W1603	WXD0513	WYB1816	DGD0526	DTN0814	L2.5 L4.0
WTJNR/L2020K16	●	●	20	20	125	32	20	25							
WTJNR/L2525M16	●	●	25	25	150	32	25	32							
WTJNR/L3232P16	●	●	32	32	170	35	32	40							

● Stock ○ Available upon Order

BTJNR/L

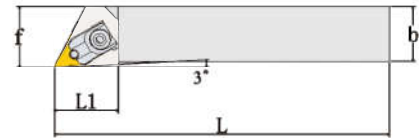
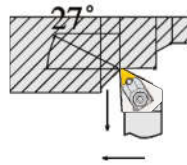

Ordering Code	Stock		Dimensions(mm)						Insert	Pad	Pin	Pressingplate	Screw	Spring	Wrench
	R	L	h	b	L	L1	h1	f							
BTJNR/L1616H16	●	●	16	16	100	30	16	20	TN**1604	TN-B1603	CTM5-S	BT16-N	BCS06	CR05	L2.5/3.0
BTJNR/L2020K16	●	●	20	20	125	33	20	25				BT16	BCS08	CR07	L3.0
BTJNR/L2525M16	●	●	25	25	150	33	25	32				L4.0			
BTJNR/L3232P16	●	●	32	32	170	37	32	40							

MTQNR/L

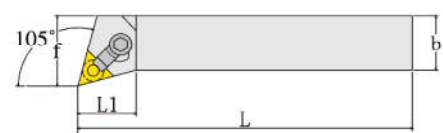
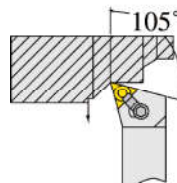

Ordering Code	Stock		Dimensions(mm)						Insert	Pad	Pin	Pressingplate	Screw	Wrench	
	R	L	h	b	L	L1	h1	f							
MTQNR/L1616H16	●	●	16	16	100	30	16	20	TN**1604	TN-M1603	MXD0513	MYB1814	ST0625	L2.0	
MTQNR/L2020K16	●	●	20	20	125	30	20	25							L3.0
MTQNR/L2525M16	●	●	25	25	150	30	25	32							
MTQNR/L3232P16	●	●	32	32	170	32	32	40							

● Stock ○ Available upon Order

Turning inserts

External turning

Internal turning

Grooving & parting

Threading

Milling

Boring & drilling

Tool holder

Solid carbide end mills

Solid carbide drill & taps

Technical information

DTQNR/L

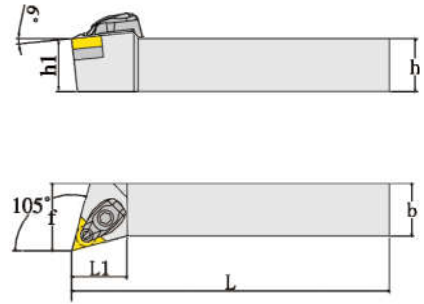
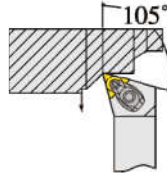

Ordering Code	Stock		Dimensions(mm)						Insert	Pad	Pin	Pressingplate	Screw	Spring	Wrench
	R	L	h	b	L	L1	h1	f							
DTQNR/L1616H16	○	○	16	16	100	32	16	20	TN**1604	TN-D1603	DXD0512	DYB2313	DGD0520	DTN0814	L4.0
DTQNR/L2020K16	●	●	20	20	125	32	20	25							
DTQNR/L2525M16	●	●	25	25	150	32	25	32							
DTQNR/L3232P16	●	●	32	32	170	35	32	40							

WTQNR/L

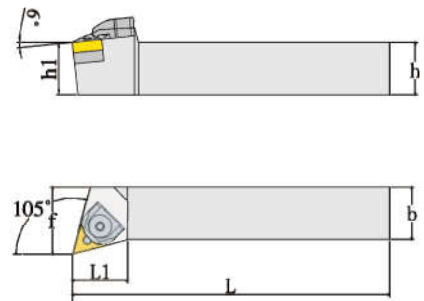
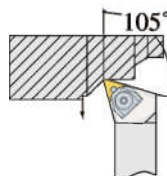

Ordering Code	Stock		Dimensions(mm)						Insert	Pad	Pin	Pressingplate	Screw	Spring	Wrench
	R	L	h	b	L	L1	h1	f							
WTQNR/L1616H16	●	●	16	16	100	32	16	20	TN**1604	TN-W1603	WXD0513	WYB1816	DGD0526	DTN0814	L2.5 L4.0
WTQNR/L2020K16	●	●	20	20	125	32	20	25							
WTQNR/L2525M16	●	●	25	25	150	32	25	32							
WTQNR/L3232P16	●	●	32	32	170	35	32	40							

● Stock ○ Available upon Order

MTFNR/L

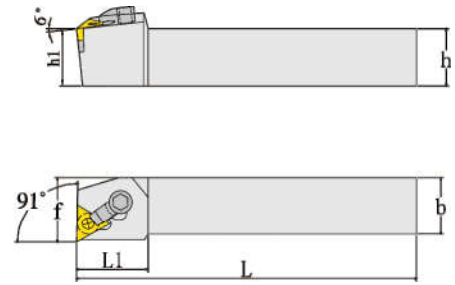
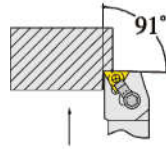

Ordering Code	Stock		Dimensions(mm)						Insert	Pad	Pin	Pressing plate	Screw	Wrench
	R	L	h	b	L	L1	h1	f						
MTFNR/L1616H16	●	●	16	16	100	32	16	20	TN**1604	TN-M1603	MXD0513	MYB1814	ST0625	L2.0 L3.0
MTFNR/L2020K16	●	●	20	20	125	32	20	25						
MTFNR/L2525M16	●	●	25	25	150	32	25	32						
MTFNR/L3232P16	●	●	32	32	170	35	32	40						

PTFNR/L

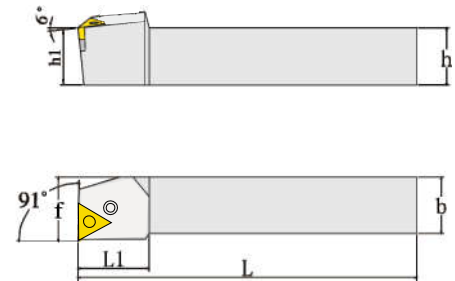
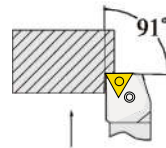

Ordering Code	Stock		Dimensions(mm)						Insert	Pad	Level	Shim	Screw	Wrench
	R	L	h	b	L	L1	h1	f						
PTFNR/L1616H16	○	○	16	16	100	22	16	20	TN**1604	TN-P1603	GGX0310	DPX0505	NLJ0618	L3.0
PTFNR/L2020K16	●	●	20	20	125	22	20	25						
PTFNR/L2525M16	●	●	25	25	150	28	25	32						
PTFNR/L3232P16	●	●	32	32	170	32	32	40						

● Stock ○ Available upon Order

Turning inserts

External turning

Internal turning

Grooving & parting

Threading

Milling

Boring & drilling

Tool holder

Solid carbide end mills

Solid carbide drill & taps

Technical information

MTGNR/L

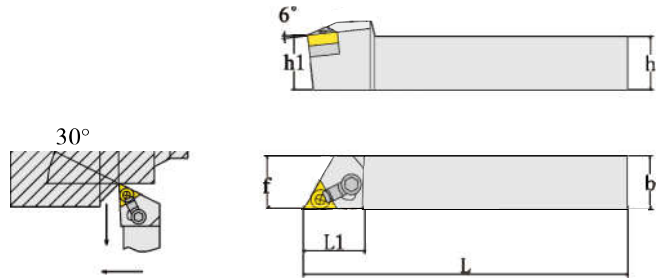

Ordering Code	Stock		Dimensions(mm)						Insert	Pad	Pin	Pressing plate	Screw	Wrench
	R	L	h	b	L	L1	h1	f						
MTGNR/L1616H16	●	●	16	16	100	32	16	20	TN**1604	TN-M1603	MXD0513	MYB1814	ST0625	L2.0 L3.0
MTGNR/L2020K16	●	●	20	20	125	32	20	25						
MTGNR/L2525M16	●	●	25	25	150	32	25	32						
MTGNR/L3232P16	●	●	32	32	170	35	32	40						

PTGNR/L

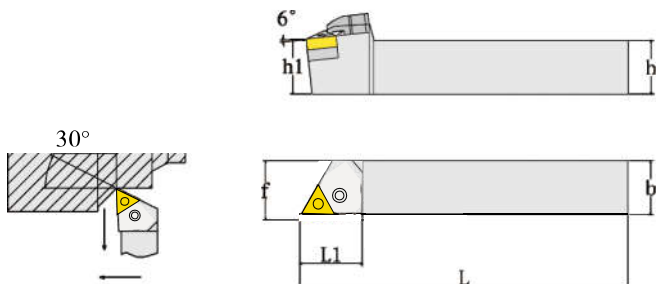

Ordering Code	Stock		Dimensions(mm)						Insert	Pad	Level	Shim	Screw	Wrench
	R	L	h	b	L	L1	h1	f						
PTGNR/L1616H16	○	○	16	16	100	22	16	20	TN**1604	TN-P1603	GGX0310	DPX0505	NLJ0618	L3.0
PTGNR/L2020K16	●	●	20	20	125	22	20	25						
PTGNR/L2525M16	●	●	25	25	150	28	25	32						
PTGNR/L3232P16	●	●	32	32	170	32	32	40						

● Stock ○ Available upon Order

MTENN

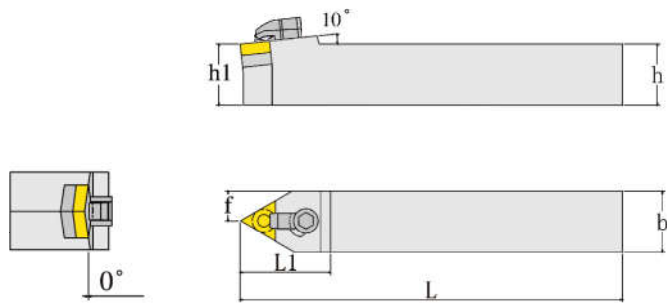

Ordering Code	Stock	Dimensions(mm)						Insert	Pad	Pin	Pressing plate	Screw	Wrench
		h	b	L	L1	h1	f						
MTENN1616H16	●	16	16	100	32	16	20						
MTENN2020K16	●	20	20	125	32	20	25						
MTENN2525M16	●	25	25	150	32	25	32						
MTENN3232P16	●	32	32	170	35	32	40						

PTENN

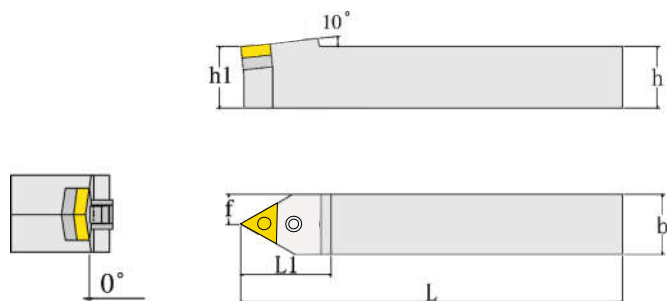

Ordering Code	Stock	Dimensions(mm)						Insert	Pad	Level	Shim	Screw	Wrench
		h	b	L	L1	h1	f						
PTENN1616H16	○	16	16	100	22	16	20						
PTENN2020K16	●	20	20	125	22	20	25						
PTENN2525M16	●	25	25	150	28	25	32						
PTENN3232P16	●	32	32	170	32	32	40						

● Stock ○ Available upon Order

Turning inserts

External turning

Internal turning

Grooving & parting

Threading

Milling

Boring & drilling

Tool holder

Solid carbide end mills

Solid carbide drill & taps

Technical information

WTENN

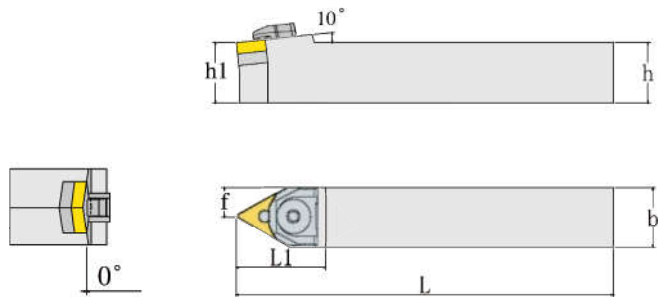

Ordering Code	Stock	Dimensions(mm)							Insert	Pad	Pin	Pressing plate	Screw	Spring	Wrench
		h	b	L	L1	h1	f								
WTENN1616H16	●	16	16	100	35	16	20	TN**1604	TN-W1603	WXD0513	WYB1816	DGD0526	DTN0814	L2.5 L4.0	
WTENN2020K16	●	20	20	125	35	20	25								
WTENN2525M16	●	25	25	150	35	25	32								
WTENN3232P16	●	32	32	170	38	32	40								

MVJNR/L

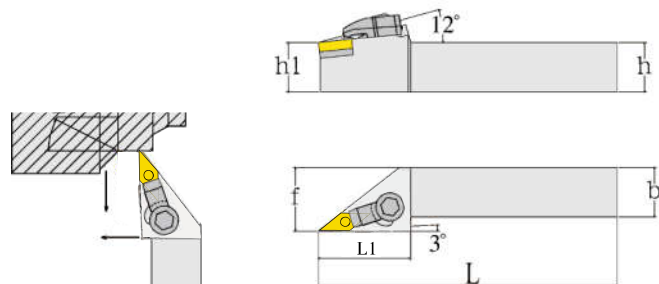





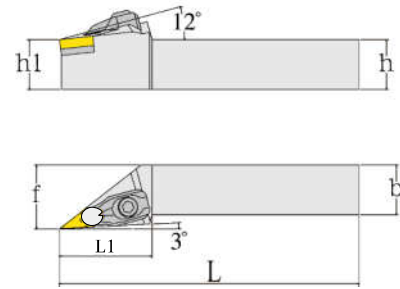
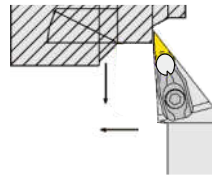

Ordering Code	Stock		Dimensions(mm)							Insert	Pad	Pin	Pressing plate	Screw	Wrench
	R	L	h	b	L	L1	h1	f							
MVJNR/L1616H16	●	●	16	16	100	36	16	20	VN**1604	VN-M1603	MXD0513	MYB2614	ST0625	L2.5 L3.0	
MVJNR/L2020K16	●	●	20	20	125	36	20	25							
MVJNR/L2525M16	●	●	25	25	150	42	25	32							
MVJNR/L3232P16	●	●	32	32	170	45	32	40							

● Stock ○ Available upon Order







DVJNR/L

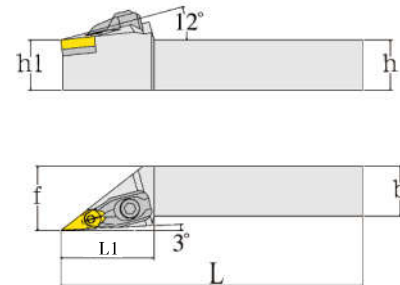
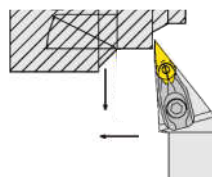

Ordering Code	Stock		Dimensions(mm)						Insert	Pad	Pin	Pressing plate	Screw	Spring	Wrench	
	R	L	h	b	L	L1	h1	f								
DVJNR/L1616H16	○	○	16	16	100	45	16	20	      	VN**1604	VN-D1603	DXD0512	DYB2914	DGD0520	DTN0814	L4.0
DVJNR/L2020K16	●	●	20	20	125	45	20	25								
DVJNR/L2525M16	●	●	25	25	150	45	25	32								
DVJNR/L3232P16	●	●	32	32	170	48	32	40								

BVJNR/L



Ordering Code	Stock		Dimensions(mm)						Insert	Pad	Pin	Pressing plate	Screw	Spring	Wrench	
	R	L	h	b	L	L1	h1	f								
BVJNR/L1616H16	○	○	16	16	100	45	16	20	      	VN**1604	VN-B1603	CTM5-S	BV16	BCS06	CR05	L2.5 L3.0
BVJNR/L2020K16	●	●	20	20	125	45	20	25								
BVJNR/L2525M16	●	●	25	25	150	45	25	32								
BVJNR/L3232P16	●	●	32	32	170	48	32	40								

● Stock ○ Available upon Order

Turning inserts

External turning

Internal turning

Grooving & parting

Threading

Milling

Boring & drilling

Tool holder

Solid carbide end mills

Solid carbide drill & taps

Technical information

Turning inserts

External turning

Internal turning

Grooving & parting

Threading

Milling

Boring & drilling

Tool holder

Solid carbide end mills

Solid carbide drill & taps

Technical information

MVQNR/L

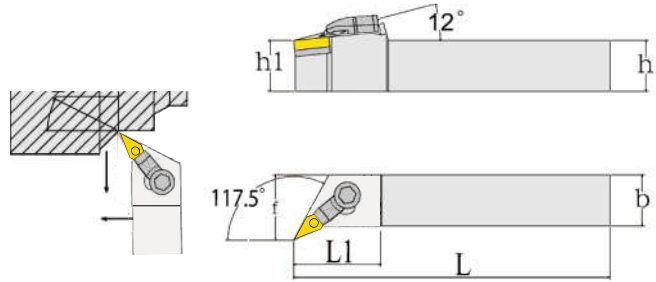

Ordering Code	Stock		Dimensions(mm)						Insert	Pad	Pin	Pressing plate	Screw	Wrench
	R	L	h	b	L	L1	h1	f						
MVQNR/L1616H16	●	●	16	16	100	36	16	20	VN**1604	VN-M1603	MXD0513	MYB2614	ST0625	L2.5 L3.0
MVQNR/L2020K16	●	●	20	20	125	36	20	25						
MVQNR/L2525M16	●	●	25	25	150	42	25	32						
MVQNR/L3232P16	●	●	32	32	170	45	32	40						

DVQNR/L

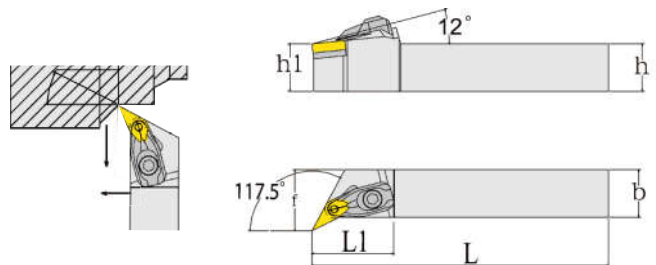

Ordering Code	Stock		Dimensions(mm)						Insert	Pad	Pin	Pressing plate	Screw	Spring	Wrench
	R	L	h	b	L	L1	h1	f							
DVQNR/L1616H16	○	○	16	16	100	44	16	20	VN**1604	VN-D1603	DXD0512	DYB2914	DGD0520	DTN0814	L4.0
DVQNR/L2020K16	●	●	20	20	125	44	20	25							
DVQNR/L2525M16	●	●	25	25	150	46	25	32							
DVQNR/L3232P16	●	●	32	32	170	46	32	40							

● Stock ○ Available upon Order

MVUNR/L

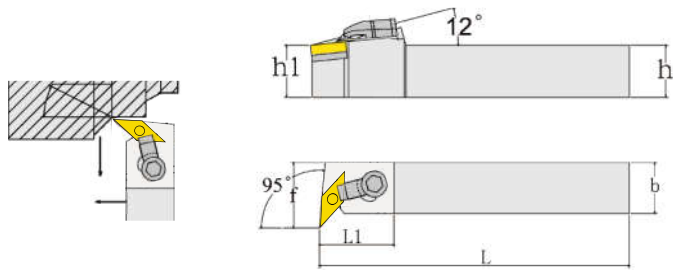

Ordering Code	Stock		Dimensions(mm)						Insert	Pad	Pin	Pressingplate	Screw	Wrench
	R	L	h	b	L	L1	h1	f						
MVUNR/L1616H16	●	●	16	16	100	36	16	20	VN**1604	VN-M1603	MXD0513	MYB2614	ST0625	L2.5 L3.0
MVUNR/L2020K16	●	●	20	20	125	36	20	25						
MVUNR/L2525M16	●	●	25	25	150	42	25	32						
MVUNR/L3232P16	●	●	32	32	170	45	32	40						

DVUNR/L

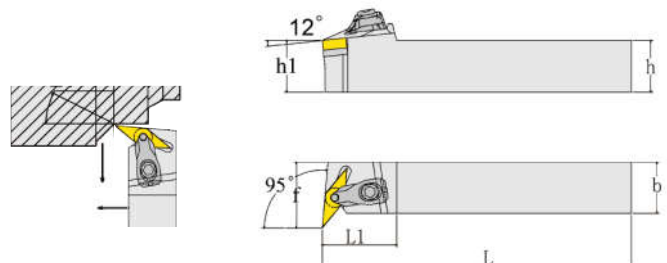

Ordering Code	Stock		Dimensions(mm)						Insert	Pad	Pin	Pressingplate	Screw	Spring	Wrench
	R	L	h	b	L	L1	h1	f							
DVUNR/L1616H16	○	○	16	16	100	38	16	20	VN**1604	VN-D1603	DXD0512	DYB2914	DGD0520	DTN0814	L4.0
DVUNR/L2020K16	●	●	20	20	125	38	20	25							
DVUNR/L2525M16	●	●	25	25	150	45	25	32							
DVUNR/L3232P16	●	●	32	32	170	45	32	40							

● Stock ○ Available upon Order

Turning inserts

External turning

Internal turning

Grooving & parting

Threading

Milling

Boring & drilling

Tool holder

Solid carbide end mills

Solid carbide drill & taps

Technical information

Turning inserts

External turning

Internal turning

Grooving & parting

Threading

Milling

Boring & drilling

Tool holder

Solid carbide end mills

Solid carbide drill & taps

Technical information

MVVNN

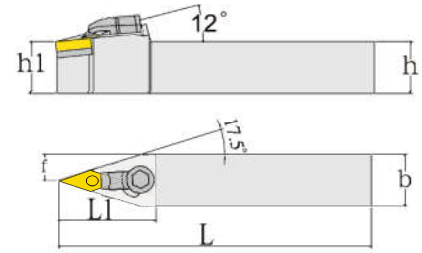
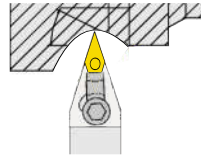

Ordering Code	Stock	Dimensions(mm)						Insert	Pad	Pin	Pressing plate	Screw	Wrench
		h	b	L	L1	h1	f						
MVVNN1616H16	●	16	16	100	48	16	20	VN**1604	VN-M1603	MXD0513	MYB2614	ST0625	L2.5 L3.0
MVVNN2020K16	●	20	20	125	48	20	25						
MVVNN2525M16	●	25	25	150	48	25	32						
MVVNN3232P16	●	32	32	170	48	32	40						

DVVNN

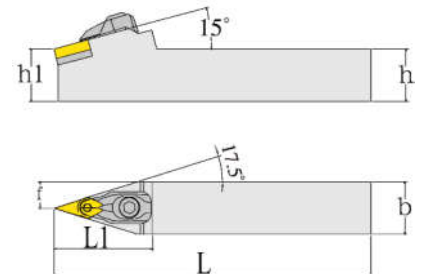
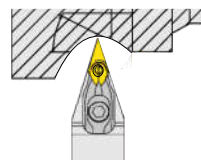

Ordering Code	Stock	Dimensions(mm)						Insert	Pad	Pin	Pressing plate	Screw	Spring	Wrench
		h	b	L	L1	h1	f							
DVVNN1616H16	●	16	16	100	48	16	20	VN**1604	VN-D1603	DXD0512	DYB2914	DGD0520	DTN0814	L4.0
DVVNN2020K16	●	20	20	125	48	20	25							
DVVNN2525M16	●	25	25	150	48	25	32							
DVVNN3232P16	●	32	32	170	48	32	40							

● Stock ○ Available upon Order

MWLNR/L

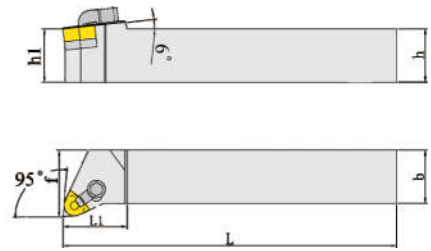
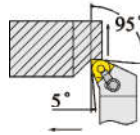

Ordering Code	Stock		Dimensions(mm)						Insert	Pad	Pin	Pressing plate	Screw	Wrench
	R	L	h	b	L	L1	h1	f						
MWLNR/L1616H06	●	●	16	16	100	25	16	20	WN**0604	WN-M0603	MXD0513	MYB1814	ST0625	L2.0 L3.0
MWLNR/L2020K06	●	●	20	20	125	25	20	25						
MWLNR/L2525M06	●	●	25	25	150	28	25	32						
MWLNR/L1616H08	●	●	32	32	170	30	32	40	WN**0804	WN-M0804	MXD0617	MYB1814	ST0625	L2.5 L3.0
MWLNR/L2020K08	●	●	20	20	125	30	20	25						
MWLNR/L2525M08	●	●	25	25	150	30	25	32						
MWLNR/L3232P08	●	●	32	32	170	30	32	40						

PWLNR/L

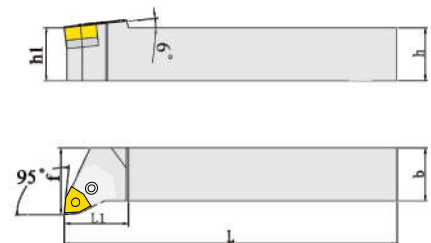
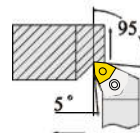

Ordering Code	Stock		Dimensions(mm)						Insert	Pad	Level	Shim	Screw	Wrench
	R	L	h	b	L	L1	h1	f						
PWLNR/L1616H06	●	●	16	16	100	20	16	20	WN**0604	WN-P0602	GGX0310	DPX0505	NLJ0618	L3.0
PWLNR/L2020K06	●	●	20	20	125	25	20	25						
PWLNR/L2525M06	●	●	25	25	150	25	25	32						
PWLNR/L1616H08	●	●	16	16	100	26	16	20	WN**0804	WN-P0803	GGX0514	DPX0606	NLJ0820	L3.0
PWLNR/L2020K08	●	●	20	20	125	26	20	25						
PWLNR/L2525M08	●	●	25	25	150	26	25	32						
PWLNR/L3232P08	●	●	32	32	170	30	32	40						

● Stock ○ Available upon Order

Turning inserts

External turning

Internal turning

Grooving & parting

Threading

Milling

Boring & drilling

Tool holder

Solid carbide end mills

Solid carbide drill & taps

Technical information

Turning inserts

External turning

Internal turning

Grooving & parting

Threading

Milling

Boring & drilling

Tool holder

Solid carbide end mills

Solid carbide drill & taps

Technical information

DWLNR/L

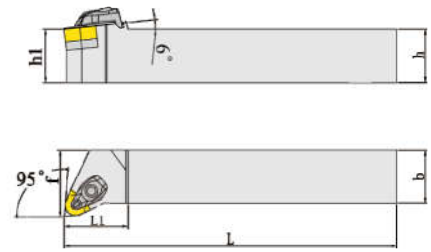
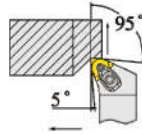

Ordering Code	Stock		Dimensions(mm)						Insert	Pad	Pin	Pressingplate	Screw	Spring	Wrench
	R	L	h	b	L	L1	h1	f							
DWLNR/L1616H06	●	●	16	16	100	28	16	20	WN**0604	WN-D0603	DXD0512	DYB2313	DGD0520	DTN0814	L4.0
DWLNR/L2020K06	●	●	20	20	125	28	20	25							
DWLNR/L2525M06	●	●	25	25	150	30	25	32							
DWLNR/L1616H08	●	●	16	16	100	30	16	20	WN**0804	WN-D0804	DXD0614	DYB2214	DGD0520	DTN0814	L4.0
DWLNR/L2020K08	●	●	20	20	125	32	20	25							
DWLNR/L2525M08	●	●	25	25	150	32	25	32							
DWLNR/L3232P08	●	●	32	32	170	35	32	40							

BWLNR/L

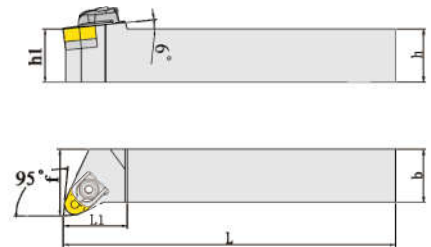
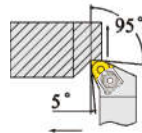

Ordering Code	Stock		Dimensions(mm)						Insert	Pad	Pin	Pressingplate	Screw	Spring	Wrench
	R	L	h	b	L	L1	h1	f							
BWLNR/L1616H06	○	○	16	16	100	28	16	20	WN**0604	WN-B0603	CTM5-S	BW06	BCS06	CR05	L2.5 L3.0
BWLNR/L2020K06	○	○	20	20	125	28	20	25							
BWLNR/L2525M06	○	○	25	25	150	30	25	32							
BWLNR/L1616H08	●	●	16	16	100	30	16	20	WN**0804	WN-B0804	CTM6-S	BW08	BCS08	CR07	L3.0 L4.0
BWLNR/L2020K08	●	●	20	20	125	32	20	25							
BWLNR/L2525M08	●	●	25	25	150	32	25	32							
BWLNR/L3232P08	●	●	32	32	170	35	32	40							

● Stock ○ Available upon Order

SCLCR/L

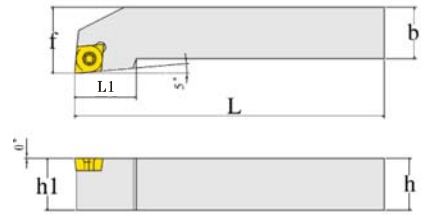

Ordering Code	Stock		Dimensions(mm)						Insert	Screw	Wrench
	R	L	h	b	L	L1	h1	f			
SCLCR/L1010H06	●	●	10	10	100	15	10	12	CC**0602	M2.5*6	T-8
SCLCR/L1212H06	●	●	12	12	100	15	12	16			
SCLCR/L1212H09	●	●	12	12	100	20	12	16	CC**09T3	M3.5*8	T-15
SCLCR/L1616H09	●	●	16	16	100	20	16	20			
SCLCR/L2020K09	●	●	20	20	125	22	20	25			
SCLCR/L2525M09	●	●	25	25	150	22	25	32	CC**1204	M5*12	T-20
SCLCR/L2020K12	●	●	20	20	125	22	20	25			
SCLCR/L2525M12	●	●	25	25	150	28	25	32			
SCLCR/L3232P12	○	○	32	32	170	28	32	40			

SCKCR/L

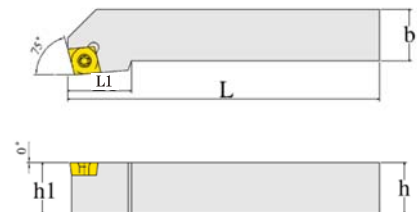





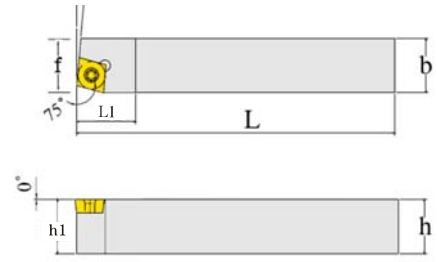
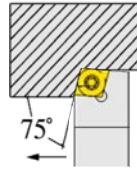

Ordering Code	Stock		Dimensions(mm)						Insert	Screw	Wrench
	R	L	h	b	L	L1	h1	f			
SCKCR/L1212H09	●	●	12	12	100	20	12	16	CC**09T3	M3.5*8	T-15
SCKCR/L1616H09	●	●	16	16	100	22	16	20			
SCKCR/L2020K09	●	●	20	20	125	22	20	25			
SCKCR/L2525M09	●	●	25	25	150	22	25	32	CC**1204	M5*12	T-20
SCKCR/L2020K12	●	●	20	20	125	22	20	25			
SCKCR/L2525M12	●	●	25	25	150	22	25	32			
SCKCR/L3232P12	○	○	32	32	170	28	32	40			

● Stock ○ Available upon Order







SCBCR/L

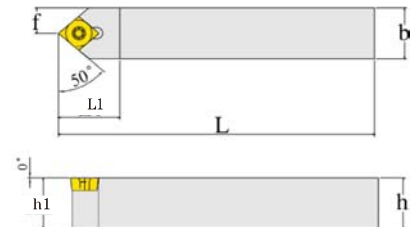
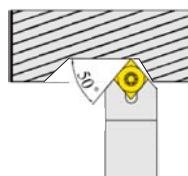

Order ng Code	Stock		Dimensions(mm)						Insert	Screw	Wrench
	R	L	h	b	L	L1	h1	f			
SCBCR/L1616H09	●	●	16	16	100	22	16	20			T-15
SCBCR/L2020K09	●	●	20	20	125	22	20	25			
SCBCR/L2525M09	●	●	25	25	150	22	25	32			
SCBCR/L2020K12	●	●	20	20	125	22	20	25			T-20
SCBCR/L2525M12	●	●	25	25	150	28	25	32			

SCMCN



Order ng Code	Stock	Dimensions(mm)						Insert	Screw	Wrench
		h	b	L	L1	h1	f			
SCMCN1010H06	○	10	10	100	15	10	12			T-8
SCMCN1212H06	○	12	12	100	15	12	16			
SCMCN1212H09	●	12	12	100	20	12	16			T-15
SCMCN1616H09	●	16	16	100	20	16	20			
SCMCN2020K09	●	20	20	125	22	20	25			
SCMCN2525M09	○	25	25	150	22	25	32			

● Stock ○ Available upon Order

SDJCR/L

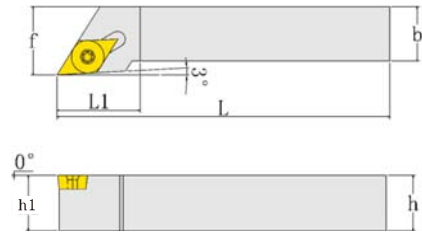

Ordering Code	Stock		Dimensions(mm)						Insert	Screw	Wrench
	R	L	h	b	L	L1	h1	f			
SDJCR/L1010H07	●	●	10	10	100	16	10	12	DC**0702	M2.5*6	T-8
SDJCR/L1212H07	●	●	12	12	100	16	12	16			
SDJCR/L1616H07	●	●	16	16	100	20	16	20	DC**11T3	M3.5*8	T-15
SDJCR/L1212H11	●	●	12	12	100	22	12	16			
SDJCR/L1616H11	●	●	16	16	100	22	16	20			
SDJCR/L2020K11	●	●	20	20	125	25	20	25	DC**11T3	M3.5*8	T-15
SDJCR/L2525M11	●	●	25	25	150	32	25	32			
SDJCR/L3232P11	●	●	32	32	170	32	32	40			

SDQCR/L

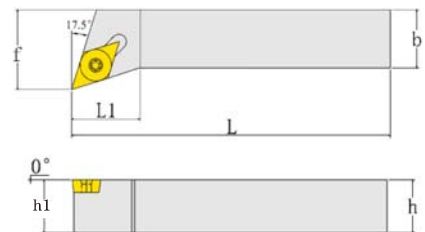

Ordering Code	Stock		Dimensions(mm)						Insert	Screw	Wrench
	R	L	h	b	L	L1	h1	f			
SDQCR/L1010H07	●	●	10	10	100	16	10	12	DC**0702	M2.5*6	T-8
SDQCR/L1212H07	●	●	12	12	100	16	12	16			
SDQCR/L1212H11	●	●	12	12	100	18	12	16	DC**11T3	M3.5*8	T-15
SDQCR/L1616H11	●	●	16	16	100	22	16	20			
SDQCR/L2020K11	●	●	20	20	125	22	20	25			
SDQCR/L2525M11	●	●	25	25	150	22	25	32			

● Stock ○ Available upon Order

Turning inserts

External turning

Internal turning

Grooving & parting

Threading

Milling

Boring & drilling

Tool holder

Solid carbide end mills

Solid carbide drill & taps

Technical information

Turning inserts

External turning

Internal turning

Grooving & parting

Threading

Milling

Boring & drilling

Tool holder



Solid carbide end mills

Solid carbide drill & taps

Technical information

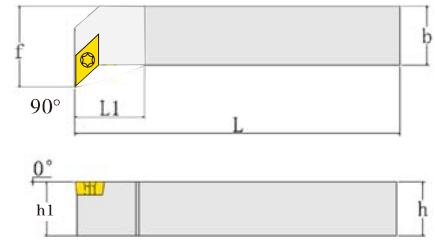

SDFCR/L

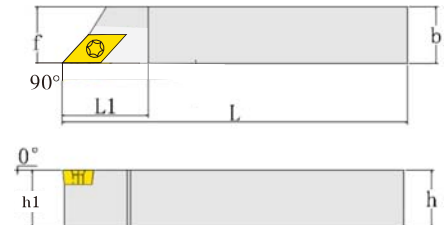

Order ng Code	Stock		Dimensions(mm)						Insert	Screw	Wrench
	R	L	h	b	L	L1	h1	f			
SDFCR/L1212H07	●	●	12	12	100	16	12	16	DC**0702	M2.5*6	T-8
SDFCR/L1616H11	●	●	16	16	100	18	16	20			
SDFCR/L2020K11	●	●	20	20	125	22	20	25			
SDFCR/L2525M11	●	●	25	25	150	22	25	32			
SDFCR/L3232P11	●	●	32	32	170	32	32	40			

SDACR/L



Order ng Code	Stock		Dimensions(mm)						Insert	Screw	Wrench
	R	L	h	b	L	L1	h1	f			
SDACR/L0808H07	●	●	8	8	100	15	8	8	DC**0702	M2.5*6	T-8
SDACR/L1010H07	●	●	10	10	100	15	10	12			
SDACR/L1212H07	●	●	12	12	100	15	12	16			
SDACR/L1616H07	●	●	16	16	100	20	16	20	DC**11T3	M3.5*8	T-15
SDACR/L1212H11	●	●	12	12	100	22	12	16			
SDACR/L1616H11	●	●	16	16	100	22	16	20	DC**11T3	M3.5*8	T-15
SDACR/L2020K11	●	●	20	20	125	22	20	25			
SDACR/L2525M11	●	●	25	25	150	22	25	32			

● Stock ○ Available upon Order

SDNCN

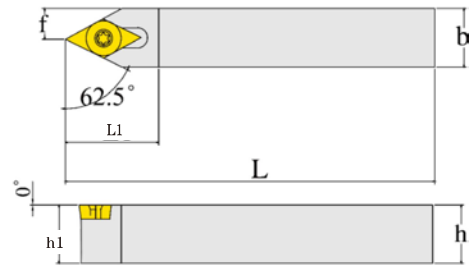

Ordering Code	Stock		Dimensions(mm)						Insert	Screw	Wrench
	R	L	h	b	L	L1	h1	f			
SDNCN0808H07	●	●	8	8	100	16	8	8	DC**0702	M2.5*6	T-8
SDNCN1010H07	●	●	10	10	100	16	10	12			
SDNCN1212H07	●	●	12	12	100	18	12	16	DC**11T3	M3.5*8	T-15
SDNCN1616H07	●	●	16	16	100	22	16	20			
SDNCN1212H11	●	●	12	12	100	22	12	16			
SDNCN1616H11	●	●	16	16	100	27	16	20	DC**11T3	M3.5*8	T-15
SDNCN2020K11	●	●	20	20	125	27	20	25			
SDNCN2525M11	●	●	25	25	150	27	25	32			

SSBCR/L

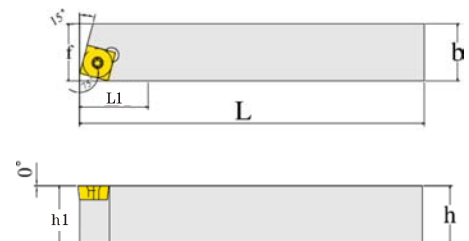

Ordering Code	Stock		Dimensions(mm)						Insert	Screw	Wrench
	R	L	h	b	L	L1	h1	f			
SSBCR/L1212H09	●	●	12	12	100	16	12	16	SC**09T3	M3.5*8	T-15
SSBCR/L1616H09	●	●	16	16	100	20	16	20			
SSBCR/L2020H09	●	●	20	20	125	20	20	25			
SSBCR/L2020K12	●	●	20	20	125	20	20	25	SC**1204	M5*12	T-20
SSBCR/L2525M12	●	●	25	25	150	25	25	32			

● Stock ○ Available upon Order

Turning inserts

External turning

Internal turning

Grooving & parting

Threading

Milling

Boring & drilling

Tool holder

Solid carbide end mills

Solid carbide drill & taps

Technical information

SSKCR/L

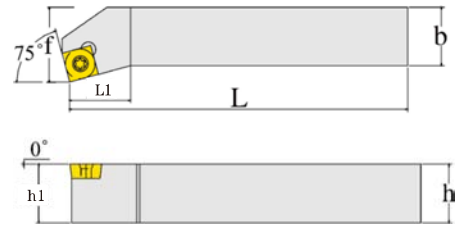

Order ng Code	Stock		Dimensions(mm)						Insert	Screw	Wrench
	R	L	h	b	L	L1	h1	f			
SSKCR/L1212H09	●	●	12	12	100	16	12	16	SC**09T3	M3.5*8	T-15
SSKCR/L1616H09	●	●	16	16	100	18	16	20			
SSKCR/L2020H09	●	●	20	20	125	22	20	25			
SSKCR/L2020K12	●	●	20	20	125	22	20	25	SC**1204	M5*12	T-20
SSKCR/L2525M12	●	●	25	25	150	30	25	32			

SSSCR/L

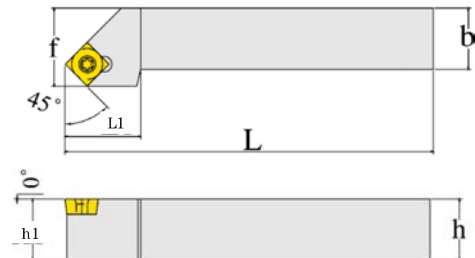

Order ng Code	Stock		Dimensions(mm)						Insert	Screw	Wrench
	R	L	h	b	L	L1	h1	f			
SSSCR/L1212H09	●	●	12	12	100	16	12	16	SC**09T3	M3.5*8	T-15
SSSCR/L1616H09	●	●	16	16	100	18	16	20			
SSSCR/L2020H09	●	●	20	20	125	22	20	25			
SSSCR/L2020K12	●	●	20	20	125	22	20	25	SC**1204	M5*12	T-20
SSSCR/L2525M12	●	●	25	25	150	30	25	32			

● Stock ○ Available upon Order

Turning inserts

External turning

Internal turning

Grooving & parting

Threading

Milling

Boring & drilling

Tool holder

Solid carbide end mills

Solid carbide drill & taps

Technical information

STGCR/L

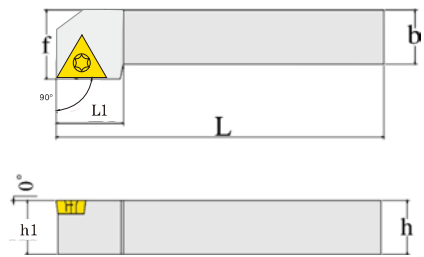

Ordering Code	Stock		Dimensions(mm)						Insert	Screw	Wrench
	R	L	h	b	L	L1	h1	f			
STGCR/L1212H11	●	●	12	12	100	18	12	16	TC**1102	M2.5*6	T-8
STGCR/L1616H11	●	●	16	16	100	20	16	20			
STGCR/L2020K16	●	●	20	20	125	30	20	25	TC**16T3	M3.5*8	T-15
STGCR/L2525M16	●	●	25	25	150	30	25	32			

STFCR/L

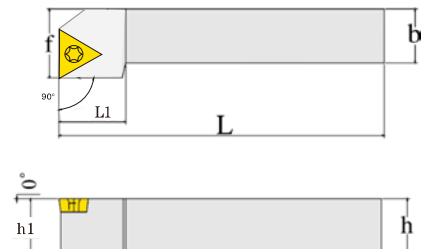

Ordering Code	Stock		Dimensions(mm)						Insert	Screw	Wrench
	R	L	h	b	L	L1	h1	f			
STFCR/L1212H11	●	●	12	12	100	18	12	16	TC**1102	M2.5*6	T-8
STFCR/L1616H11	●	●	16	16	100	20	16	20			
STFCR/L2020K16	●	●	20	20	125	30	20	25	TC**16T3	M3.5*8	T-15
STFCR/L2525M16	●	●	25	25	150	30	25	32			

● Stock ○ Available upon Order

Turning inserts

External turning

Internal turning

Grooving & parting

Threading

Milling

Boring & drilling

Tool holder

Solid carbide end mills

Solid carbide drill & taps

Technical information

SVJCR/L

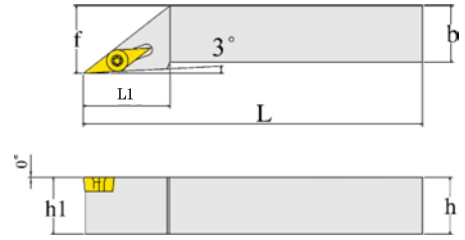

Order ng Code	Stock		Dimensions(mm)						Insert	Screw	Wrench
	R	L	h	b	L	L1	h1	f			
SVJCR/L1212H11	●	●	12	12	100	25	12	16	VC**1103	M2.5*6	T-8
SVJCR/L1616H11	●	●	16	16	100	28	16	20			
SVJCR/L2020K11	●	●	20	20	125	35	20	25			
SVJCR/L2525M11	●	●	25	25	150	32	25	32	VC**1604	M3.5*8	T-15
SVJCR/L1616H16	●	●	16	16	100	32	16	20			
SVJCR/L2020K16	●	●	20	20	125	35	20	25			
SVJCR/L2525M16	●	●	25	25	150	38	25	32			
SVJCR/L3232P16	●	●	32	32	170	45	32	40			

SVQCR/L

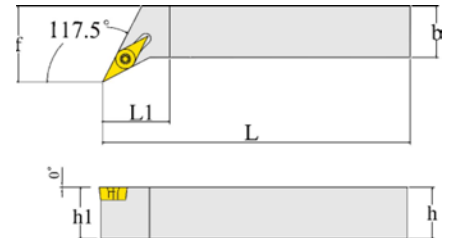

Order ng Code	Stock		Dimensions(mm)						Insert	Screw	Wrench
	R	L	h	b	L	L1	h1	f			
SVQCR/L1616H11	●	●	16	16	100	35	16	20	VC**1103	M2.5*6	T-8
SVQCR/L2020K11	●	●	20	20	125	35	20	25			
SVQCR/L1616H16	●	●	16	16	100	35	16	20	VC**1604	M3.5*8	T-15
SVQCR/L2020K16	●	●	20	20	125	35	20	25			
SVQCR/L2525M16	●	●	25	25	150	35	25	32			
SVQCR/L3232P16	●	●	32	32	170	35	32	40			

● Stock ○ Available upon Order

SVJBR/L

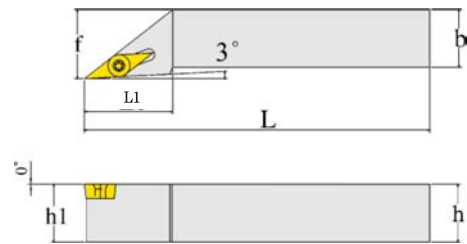

Ordering Code	Stock		Dimensions(mm)						Insert	Screw	Wrench
	R	L	h	b	L	L1	h1	f			
SVJBR/L1212H11	●	●	12	12	100	25	12	16	VB**1103	M2.5*6	T-8
SVJBR/L1616H11	●	●	16	16	100	28	16	20			
SVJBR/L2020K11	●	●	20	20	125	35	20	25			
SVJBR/L2525M11	●	●	25	25	150	32	25	32	VB**1604	M3.5*8	T-15
SVJBR/L1616H16	●	●	16	16	100	32	16	20			
SVJBR/L2020K16	●	●	20	20	125	35	20	25			
SVJBR/L2525M16	●	●	25	25	150	38	25	32			
SVJBR/L3232P16	●	●	32	32	170	45	32	40			

SVQBR/L

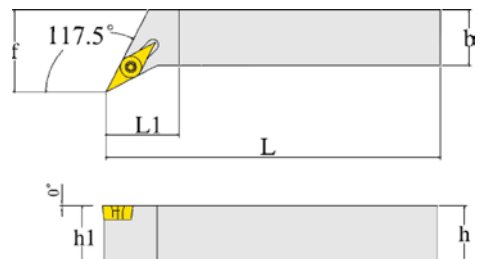

Ordering Code	Stock		Dimensions(mm)						Insert	Screw	Wrench
	R	L	h	b	L	L1	h1	f			
SVQBR/L1616H11	●	●	16	16	100	35	16	20	VB**1103	M2.5*6	T-8
SVQBR/L2020K11	●	●	20	20	125	35	20	25			
SVQBR/L1616H16	●	●	16	16	100	35	16	20	VB**1604	M3.5*8	T-15
SVQBR/L2020K16	●	●	20	20	125	35	20	25			
SVQBR/L2525M16	●	●	25	25	150	35	25	32			
SVQBR/L3232P16	●	●	32	32	170	35	32	40			

● Stock ○ Available upon Order

Turning inserts

External turning

Internal turning

Grooving & parting

Threading

Milling

Boring & drilling

Tool holder

Solid carbide end mills

Solid carbide drill & taps

Technical information

SVUC(B)R/L

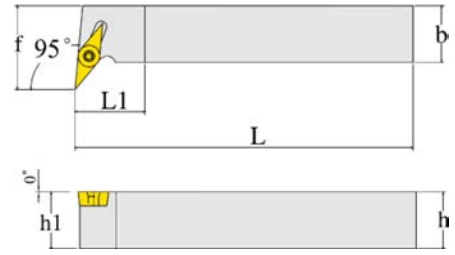

Order ng Code	Stock		Dimensions(mm)						Insert	Screw	Wrench
	R	L	h	b	L	L1	h1	f			
SVUCR/L1616H11	●	●	16	16	100	16	16	20	VC**1103	M2.5*6	T-8
SVUCR/L2020K11	●	●	20	20	125	16	20	25			
SVUCR/L1616H16	○	○	16	16	100	16	16	20	VC**1604	M3.5*8	T-15
SVUCR/L2020K16	●	●	20	20	125	16	20	25			
SVUCR/L2525M16	●	●	25	25	150	16	25	32			
SVUBR/L1616H11	●	●	16	16	100	16	16	20	VB**1103	M2.5*6	T-8
SVUBR/L2020K11	●	●	20	20	125	16	20	25			
SVUBR/L1616H16	○	○	16	16	100	16	16	20	VB**1604	M3.5*8	T-15
SVUBR/L2020K16	●	●	20	20	125	16	20	25			
SVUBR/L2525M16	●	●	25	25	150	16	25	32			

SVVC(B)N

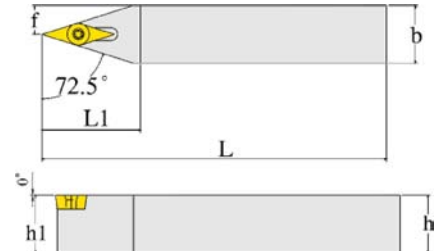

Order ng Code	Stock		Dimensions(mm)						Insert	Screw	Wrench
			h	b	L	L1	h1	f			
SVVCN1616H11	●		16	16	100	28	16	20	VC**1103	M2.5*6	T-8
SVVCN2020K11	●		20	20	125	35	20	25			
SVVCN1616H16	●		16	16	100	32	16	20	VC**1604	M3.5*8	T-15
SVVCN2020K16	●		20	20	125	35	20	25			
SVVCN2525M16	●		25	25	150	38	25	32			
SVVBN1616H11	●		16	16	100	28	16	20	VB**1103	M2.5*6	T-8
SVVBN2020K11	●		20	20	125	35	20	25			
SVVBN1616H16	●		16	16	100	32	16	20	VB**1604	M3.5*8	T-15
SVVBN2020K16	●		20	20	125	35	20	25			
SVVBN2525M16	●		25	25	150	38	25	32			

● Stock ○ Available upon Order

Turning inserts

External turning

Internal turning

Grooving & parting

Threading

Milling

Boring & drilling

Tool holder

Solid carbide end mills

Solid carbide drill & taps

Technical information

SRACR/L

CRACR/L

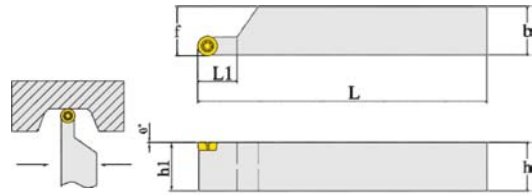

Ordering Code	Stock		Dimensions(mm)						Insert	Screw	Wrench
	R	L	h	b	L	L1	h1	f			
SRACR/L1616H06	●	●	16	16	100	15	16	20	RC**0602	M2.5*6	T-8
SRACR/L2020K06	●	●	20	20	125	20	20	25			
SRACR/L2525M06	●	●	25	25	150	25	25	32			
SRACR/L1616H08	●	●	16	16	100	15	16	20	RC**0803	M3.0*10	T-10
SRACR/L2020K08	●	●	20	20	125	20	20	25			
SRACR/L2525M08	●	●	25	25	150	20	25	32			
SRACR/L3232P08	●	●	32	32	170	25	32	40	RC**10T3	M3.5*10	T-15
SRACR/L1616H10	●	●	16	16	100	15	16	20			
SRACR/L2020K10	●	●	20	20	125	20	20	25			
SRACR/L2525M10	●	●	25	25	150	20	25	32	RC**1204	M3.5*10	T-15
SRACR/L3232P10	●	●	32	32	170	25	32	40			
SRACR/L2020K12	●	●	20	20	125	20	20	25			
SRACR/L2525M12	●	●	25	25	150	20	25	32	RC**1606	M5*12	T-20
SRACR/L3232P12	●	●	32	32	170	25	32	40			
SRACR/L4040P12	●	●	40	40	200	32	40	50			
SRACR/L2525M16	●	●	25	25	150	20	25	32	RC**2006	M5*12	T-20
SRACR/L3232P16	●	●	32	32	170	25	32	40			
SRACR/L4040R16	●	●	40	40	200	32	40	50			
SRACR/L3232P20	●	●	32	32	170	25	32	40	RC**2006	M5*12	T-20
SRACR/L4040R20	●	●	40	40	200	32	40	50			

Ordering Code	Stock		Dimensions(mm)						Insert	Pressingplate	Screw	Screw	Wrench
	R	L	h	b	L	L1	h1	f					
CRACR/L3232P12	●	●	32	32	170	25	32	40	RC**1204	M5*12	NLJ0522	M3.5*10	T-15 L4.0
CRACR/L4040R12	●	●	40	40	200	32	40	50					
CRACR/L3232P16	●	●	32	32	170	25	32	40	RC**1606	M5*12	T-20	M5*12	T-19 L4.0
CRACR/L4040R16	●	●	40	40	200	32	40	50					
CRACR/L3232P20	●	●	32	32	170	25	32	40	RC**2006	M5*12	T-20	M5*12	T-20 L4.0
CRACR/L4040R20	●	●	40	40	200	32	40	50					

● Stock ○ Available upon Order

Turning inserts

External turning

Internal turning

Grooving & parting

Threading

Milling

Boring & drilling

Tool holder



Solid carbide end mills

Solid carbide drill & taps

Technical information

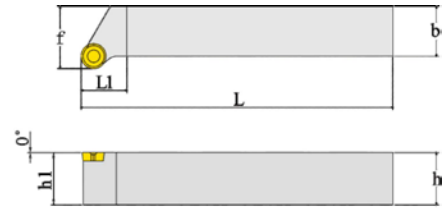
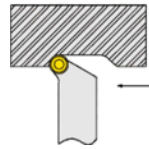
SRGCR/L



Order ng Code	Stock		Dimensions(mm)						Insert	Screw	Wrench
	R	L	h	b	L	L1	h1	f			
SRGCR/L1616H06	●	●	16	16	100	15	16	20	RC**0602	M2.5*6	T-8
SRGCR/L2020K06	●	●	20	20	125	20	20	25			
SRGCR/L2525M06	●	●	25	25	150	25	25	32			
SRGCR/L1616H08	●	●	16	16	100	15	16	20	RC**0803	M3.0*10	T-10
SRGCR/L2020K08	●	●	20	20	125	20	20	25			
SRGCR/L2525M08	●	●	25	25	150	20	25	32			
SRGCR/L3232P08	●	●	32	32	170	25	32	40	RC**10T3	M3.5*10	T-15
SRGCR/L1616H10	●	●	16	16	100	15	16	20			
SRGCR/L2020K10	●	●	20	20	125	20	20	25			
SRGCR/L2525M10	●	●	25	25	150	20	25	32	RC**1204	M3.5*10	T-15
SRGCR/L3232P10	●	●	32	32	170	25	32	40			
SRGCR/L2020K12	●	●	20	20	125	20	20	25			
SRGCR/L2525M12	●	●	25	25	150	20	25	32	RC**1606	M5*12	T-20
SRGCR/L3232P12	●	●	32	32	170	25	32	40			
SRGCR/L4040P12	●	●	40	40	200	32	40	50			
SRGCR/L2525M16	●	●	25	25	150	20	25	32	RC**2006	M5*12	T-20
SRGCR/L3232P16	●	●	32	32	170	25	32	40			
SRGCR/L4040R16	●	●	40	40	200	32	40	50			
SRGCR/L3232P20	●	●	32	32	170	25	32	40	RC**2006	M5*12	T-20
SRGCR/L4040R20	●	●	40	40	200	32	40	50			

● Stock ○ Available upon Order

- Turning inserts
- External turning
- Internal turning
- Grooving & parting
- Threading
- Milling
- Boring & drilling
- Tool holder
- Solid carbide end mills
- Solid carbide drill & taps
- Technical information

SRDCN

CRDCN

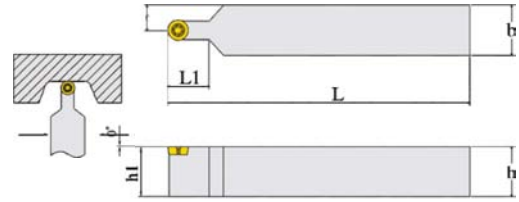

Ordering Code	Stock		Dimensions(mm)						Insert	Screw	Wrench
	R	L	h	b	L	L1	h1	f			
SRDCN1616H06	●	●	16	16	100	15	16	20	RC**0602	M2.5*6	T-8
SRDCN2020K06	●	●	20	20	125	20	20	25			
SRDCN2525M06	●	●	25	25	150	25	25	32			
SRDCN1616H08	●	●	16	16	100	15	16	20	RC**0803	M3.0*10	T-10
SRDCN2020K08	●	●	20	20	125	20	20	25			
SRDCN2525M08	●	●	25	25	150	20	25	32			
SRDCN3232P08	●	●	32	32	170	25	32	40	RC**10T3	M3.5*10	T-15
SRDCN1616H10	●	●	16	16	100	15	16	20			
SRDCN2020K10	●	●	20	20	125	20	20	25			
SRDCN2525M10	●	●	25	25	150	20	25	32	RC**1204	M3.5*10	T-15
SRDCN3232P10	●	●	32	32	170	25	32	40			
SRDCN2020K12	●	●	20	20	125	20	20	25			
SRDCN2525M12	●	●	25	25	150	20	25	32	RC**1606	M5*12	T-20
SRDCN3232P12	●	●	32	32	170	25	32	40			
SRDCN4040P12	●	●	40	40	200	32	40	50			
SRDCN2525M16	●	●	25	25	150	20	25	32	RC**2006	M5*12	T-20
SRDCN3232P16	●	●	32	32	170	25	32	40			
SRDCN4040R16	●	●	40	40	200	32	40	50			
SRDCN3232P20	●	●	32	32	170	25	32	40	RC**2006	M5*12	T-20
SRDCN4040R20	●	●	40	40	200	32	40	50			

Ordering Code	Stock		Dimensions(mm)						Insert	Pressingplate	Screw	Screw	Wrench
	R	L	h	b	L	L1	h1	f					
CRDCN3232P12	●	●	32	32	170	25	32	40	RC**1204	M5*12	NLJ0522	M3.5*10	T-15 L4.0
CRDCN4040R12	●	●	40	40	200	32	40	50					
CRDCN3232P16	●	●	32	32	170	25	32	40	RC**1606	M5*12	T-20	M5*12	T-19 L4.0
CRDCN4040R16	●	●	40	40	200	32	40	50					
CRDCN3232P20	●	●	32	32	170	25	32	40	RC**2006	M5*12	T-20	M5*12	T-20 L4.0
CRDCN4040R20	●	●	40	40	200	32	40	50					

● Stock ○ Available upon Order

Turning inserts

External turning

Internal turning

Grooving & parting

Threading

Milling

Boring & drilling

Tool holder

Solid carbide end mills

Solid carbide drill & taps

Technical information

INTERNAL TURNING TOOLS

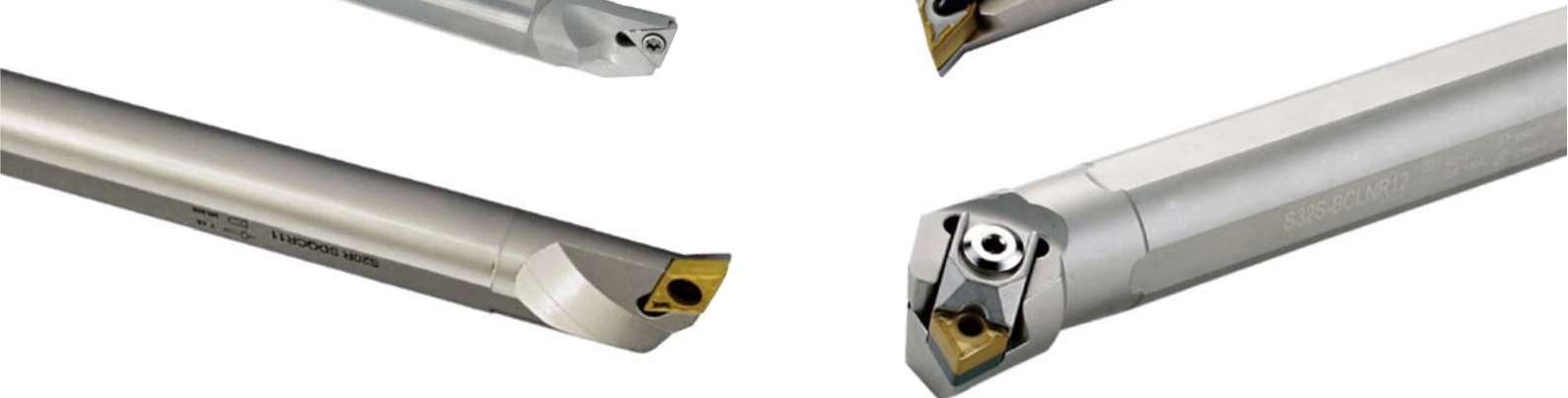

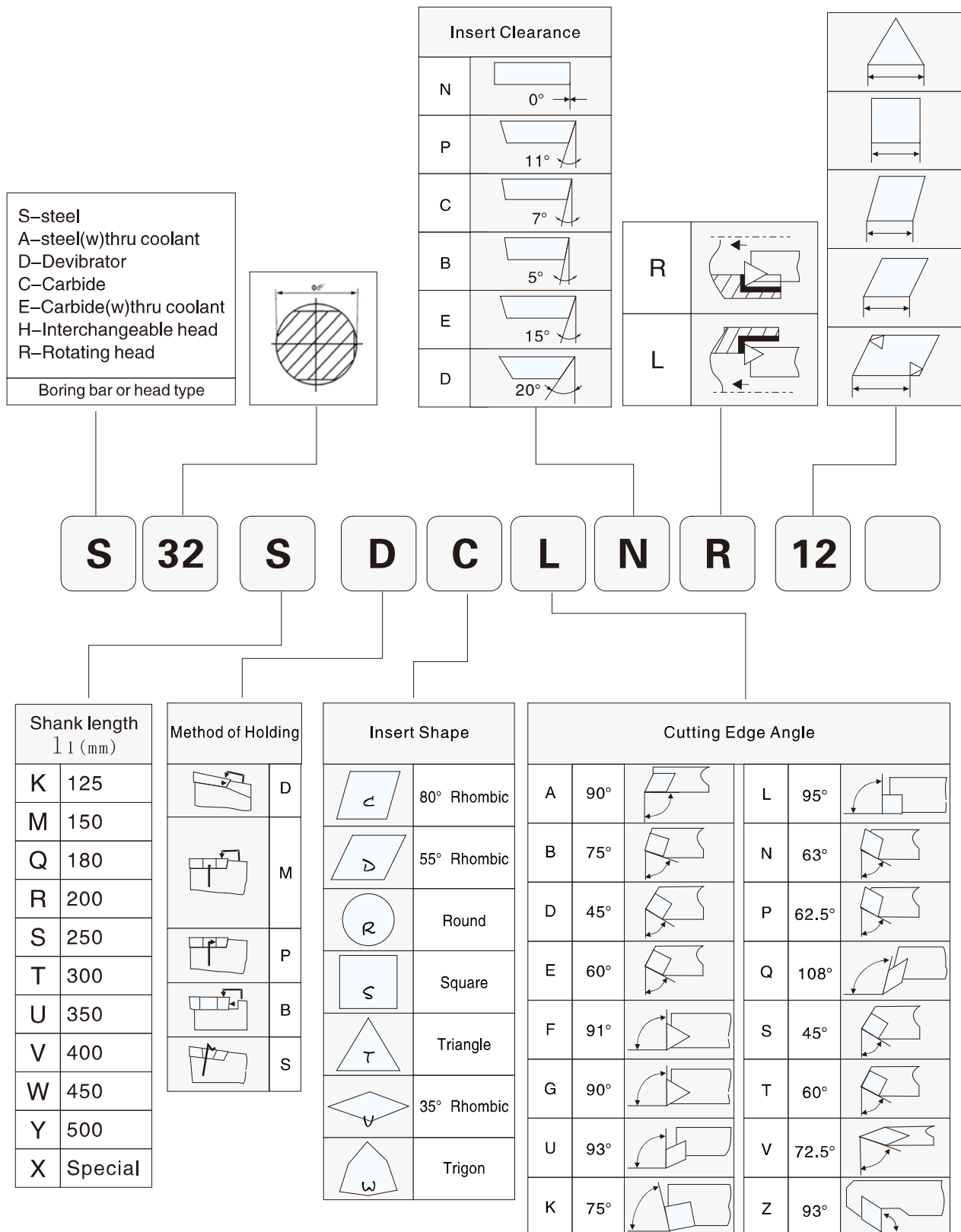

Turning inserts

External turning

Internal turning

Grooving & parting

Threading

Milling

Boring & drilling

Tool holder

Solid carbide end mills

Solid carbide drill & taps

Technical information

SMCLNR/L**



P083

SPCLNR/L**



P083

SDCLNR/L**



P084

SBCLNR/L**



P084

SMCKNR/L**



P085

SMCWNR/L**



P085

SMSKNR/L**



P086

SDDUNR/L**



P086

SPDUNR/L**



P087

SDDQNR/L**



P087

SDDZNR/L**



P088

SMTQNR/L**



P088

SMTJNR/L**



P089

SMTFNR/L**



P089

SPTUNR/L**



P090

SMTUNR/L**



P090

SDTUNR/L**



P091

SMTWNR/L**



P091

SMWLNR/L**



P092

SPWLNR/L**



P092

SDWLNR/L**



P093

SDVXNR/L**



P093

SDVQNR/L**



P094

SDVUNR/L**



P094

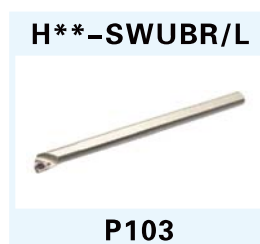
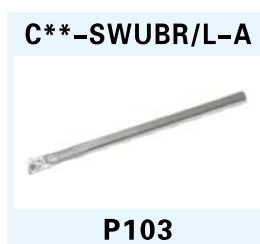
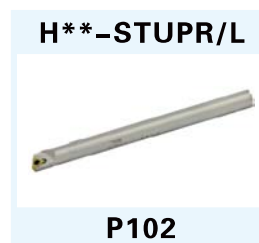

- Turning inserts
- External turning
- Internal turning
- Grooving & parting
- Threading
- Milling
- Boring & drilling
- Tool holder
- Solid carbide end mills
- Solid carbide drill & taps
- Technical information

Turning inserts

External turning

Internal turning

Grooving & parting

Threading

Milling

Boring & drilling

Tool holder

Solid carbide end mills

Solid carbide drill & taps

Technical information

S -SDQCR/L**



P106

S -SDUCR/L**



P107

S -SDZCR/L**



P107

S -SDWCR/L**



P108

S -SSSCR/L**



P108

S -SSKCR/L**



P109

S -STFCR/L**



P109

S -STUCR/L**



P110

S -STWCR/L**



P110

S -SVQB(C)R/L**



P111

S -SVUB(C)R/L**



P111

S -SVXB(C)R/L**



P112

S -SVZB(C)R/L**



P112

S -SVWCR/L**



P113

S -SWLCR/L**



P113

S**MCLNR/L

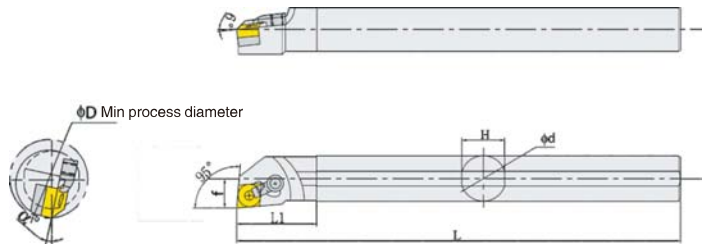

Ordering Code	Stock		Dimensions(mm)							Insert	Shim	Pin	Clamp	Screw	Wrench
	R	L	D	d	L	L1	H	f	a°						
S20Q-MCLNR/L12	●	●	25	20	180	45	18	13	15	CN**1204	※	MXD0614	MYB1811	ST0620	L2.5 L3.0
S20R-MCLNR/L12	●	●	25	20	200	45	18	13	15						
S25R-MCLNR/L12	●	●	32	25	200	45	23	16.5	12						
S25S-MCLNR/L12	●	●	32	25	250	45	23	16.5	12						
S32S-MCLNR/L12	●	●	40	32	250	50	29	22.5	17		CN-M1204	MXD0617	MYB1814	ST0625	
S32T-MCLNR/L12	●	●	40	32	300	50	29	22.5	17						
S40T-MCLNR/L12	●	●	50	40	300	55	37	26	15						
S40U-MCLNR/L12	●	●	50	40	350	55	37	26	15						

S**PCLNR/L

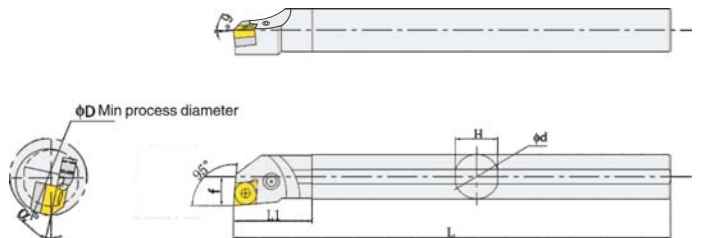

Ordering Code	Stock		Dimensions(mm)							Insert	Shim	Pin	Clamp	Screw	Wrench
	R	L	D	d	L	L1	H	f	a°						
S20R-PCLNR/L09	●	●	25	20	200	32	16	13	15	CN**0903	※	GGX0310A	※	NLJ0615	L3.0
S25S-PCLNR/L12	●	●	32	25	250	40	20	17	12			GGX0514A		NLJ0816	
S32T-PCLNR/L12	●	●	40	32	300	50	32	22	17	CN**1204	CN-P1203	GGX0514	DPX0803	NLJ0820	
S40U-PCLNR/L12	●	●	50	40	350	55	40	27	15						

● Stock ○ Available upon Order

Turning inserts

External turning

Internal turning

Grooving & parting

Threading

Milling

Boring & drilling

Tool holder

Solid carbide end mills

Solid carbide drill & taps

Technical information

Turning inserts

External turning

Internal turning

Grooving & parting

Threading

Milling

Boring & drilling

Tool holder

Solid carbide end mills

Solid carbide drill & taps

Technical information

S**DCLNR/L

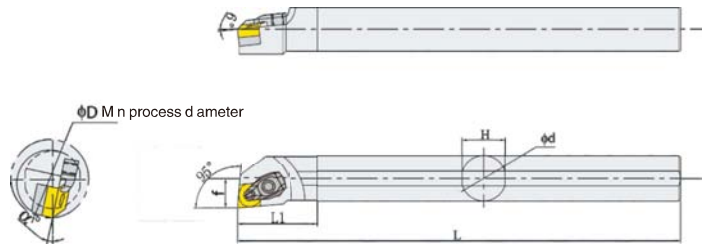

Order ng Code	Stock		D mens ons(mm)							Insert	Sh m	P n	Clamp	Screw	Spr ng	Wrench
	R	L	D	d	L	L1	H	f	a°							
S20R-DCLNR/L12	●	●	25	20	200	32	16	13	15	CN**1204	※	※	DYB2214	DGD0520	DTN0814	L4.0
S25S-DCLNR/L12	●	●	32	25	250	40	20	17	12							
S32T-DCLNR/L12	●	●	40	32	300	50	32	22	17							
S40U-DCLNR/L12	●	●	50	40	350	55	40	27	15							

S**BCLNR/L

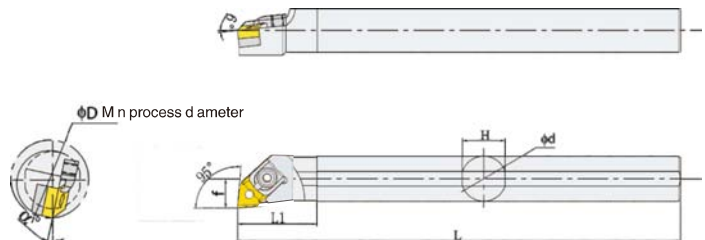

Order ng Code	Stock		D mens ons(mm)							Insert	Sh m	P n	Clamp	Screw	Spr ng	Wrench
	R	L	D	d	L	L1	H	f	a°							
S32S-BCLNR/L12	●	●	40	32	250	50	32	22	17	CN**1204	CN-B1204	CTM6-S	BC12	BCS08	CR07	L3.0 L4.0
S32T-BCLNR/L12	●	●	40	32	300	50	32	22	17							
S40U-BCLNR/L12	●	●	50	40	350	55	40	27	15							

● Stock ○ Available upon Order

S**MCKNR/L

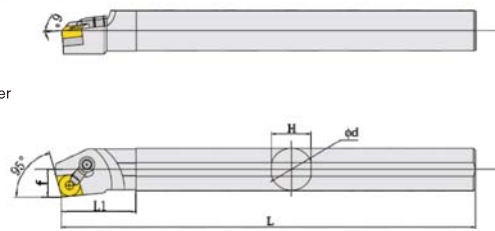
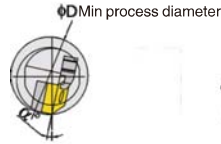

Ordering Code	Stock		Dimensions(mm)							Insert	Shim	Pin	Clamp	Screw	Wrench
	R	L	D	d	L	L1	H	f	a°						
S20Q-MCKNR/L12	●	●	25	20	180	45	18	13	15	CN**1204	※	MXD0614	MYB1811	ST0620	L2.5 L3.0
S20R-MCKNR/L12	●	●	25	20	200	45	18	13	15						
S25R-MCKNR/L12	●	●	32	25	200	45	23	16.5	12						
S25S-MCKNR/L12	●	●	32	25	250	45	23	16.5	12						
S32S-MCKNR/L12	●	●	40	32	250	50	29	22.5	17						
S32T-MCKNR/L12	●	●	40	32	300	50	29	22.5	17				CN-M1204	MXD0617	

S**MCWNR/L

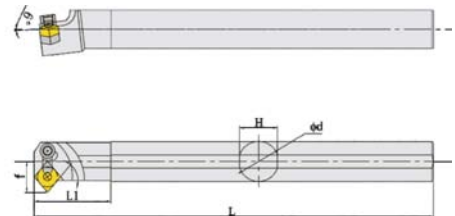

Ordering Code	Stock		Dimensions(mm)							Insert	Shim	Pin	Clamp	Screw	Wrench
	R	L	D	d	L	L1	H	f	a°						
S20R-MCWNR/L12	●	●	30	20	200	45	18	13	15	CN**1204	※	MXD0614	MYB1811	ST0620	L2.5 L3.0
S25S-MCWNR/L12	●	●	32	25	250	45	23	16.5	12						
S32T-MCWNR/L12	●	●	40	32	300	50	29	22.5	17				CN-M1204	MXD0617	

● Stock ○ Available upon Order

Turning inserts

External turning

Internal turning

Grooving & parting

Threading

Milling

Boring & drilling

Tool holder

Solid carbide end mills

Solid carbide drill & taps

Technical information

SMSKNR/L**

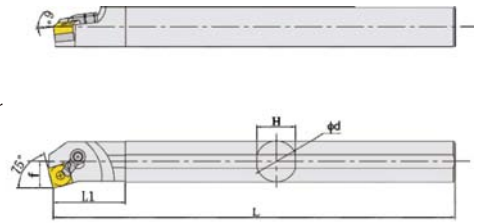
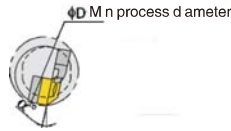

Order ng Code	Stock		D mens ons(mm)							Insert	Sh m	P n	Clamp	Screw	Wrench
	R	L	D	d	L	L1	H	f	a°						
S20R-MSKNR/L12	●	●	25	20	200	45	18	13	15	SN**1204	※	MXD0614	MYB1811	ST0620	L2.5 L3.0
S25S-MSKNR/L12	●	●	32	25	250	45	23	16.5	12		CN-M1204	MXD0617	MYB1814	ST0625	
S32T-MSKNR/L12	●	●	40	32	300	50	29	22.5	17						

SDDUNR/L**

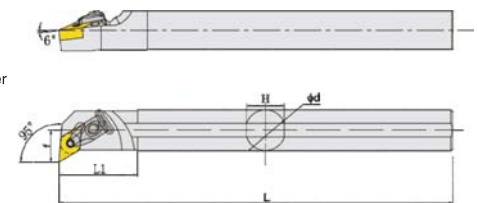
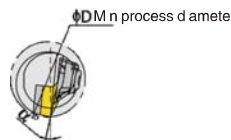

Order ng Code	Stock		D mens ons(mm)							Insert	Sh m	P n	Clamp	Screw	Wrench	Wrench
	R	L	D	d	L	L1	H	f	a°							
S25S-DDUNR/L1504	●	●	32	25	250	40	23	17	12	DN**1504	※	※	DYB2514	DGD0520	DTN0814	L4.0
S32T-DDUNR/L1504	●	●	40	32	300	50	29	22.5	17		DN-D1506	DXD0614				
S40U-DDUNR/L1504	●	●	50	40	350	55	37	26	15		DN-D1504					
S32T-DDUNR/L1506	●	●	42	32	300	50	29	22.5	17	DN**1506	DN-D1504					
S40U-DDUNR/L1506	●	●	50	40	350	55	37	26	15							

● Stock ○ Availab e upon Order

S**PDUNR/L

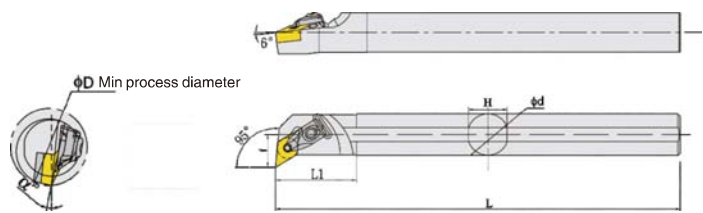

Ordering Code	Stock		Dimensions(mm)							Insert	Shim	Lever	Shim pin	Screw	Wrench
	R	L	D	d	L	L1	H	f	a°						
S20R-PDUNR/L11	●	●	25	20	200	30	18	13	15	DN**1104	※	GGX0310A	※	NLJ0617	L3.0
S25S-PDUNR/L1506	●	●	32	25	250	35	23	17	12	DN**1506	DN-P1503	GGX0514A	※	NLJ0816	
S32T-PDUNR/L1506	●	●	40	32	300	40	30	22	17			GGX0514D	DPX0606	NLJ0820	
S40U-PDUNR/L1506	●	●	50	40	350	50	37	27	15						

S**DDQNR/L

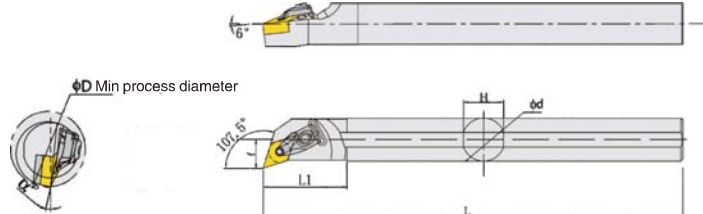

Ordering Code	Stock		Dimensions(mm)							Insert	Shim	Pin	Clamp	Screw	Wrench	Wrench
	R	L	D	d	L	L1	H	f	a°							
S25S-DDQNR/L1504	●	●	32	25	250	40	23	17	12	DN**1504	※	※	DYG0614	DYG0520	DTN0814	L4.0
S32T-DDQNR/L1504	●	●	40	32	300	50	29	22.5	17		DN-D1506					
S40U-DDQNR/L1504	●	●	50	40	350	55	37	26	15	DN**1506	DN-D1504					
S32T-DDQNR/L1506	●	●	40	32	300	50	29	22.5	17							
S40U-DDQNR/L1506	●	●	50	40	350	55	37	26	15							

● Stock ○ Available upon Order

Turning inserts

External turning

Internal turning

Grooving & parting

Threading

Milling

Boring & drilling

Tool holder

Solid carbide end mills

Solid carbide drill & taps

Technical information

SDDZNR/L**

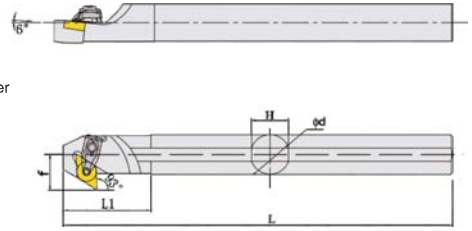
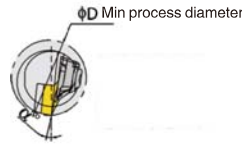

Order ng Code	Stock		Dimensions(mm)							Insert	Sh m	Pin	Clamp	Screw	Spring	Wrench
	R	L	D	d	L	L1	H	f	a°							
S25S-DDZNR/L1504	○	○	32	25	250	40	23	17	12	DN**1504	※	※	DYB2514	DGD0520	DTN0814	L4.0
S32T-DDZNR/L1504	●	●	40	32	300	50	29	22.5	17		DN-D1506	DXD0614				
S40U-DDZNR/L1504	●	●	50	40	350	55	37	26	15	DN**1506	DN-D1504					
S32T-DDZNR/L1506	●	●	40	32	300	50	29	22.5	17							
S40U-DDZNR/L1506	●	●	50	40	350	55	37	26	15							

SMTQNR/L**

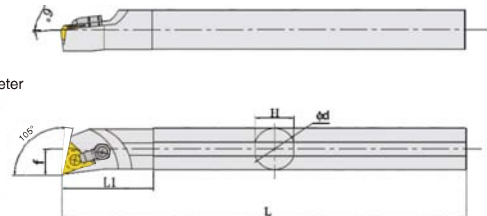
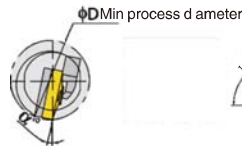

Order ng Code	Stock		Dimensions(mm)							Insert	Sh m	P n	Clamp	Screw	Wrench
	R	L	D	d	L	L1	H	f	a°						
S20R-MTQNR/L16	●	●	25	20	200	40	18	12.5	15	TN**1604	※	MXD0511	MYB1811	ST0622	L2.0 L3.0
S25S-MTQNR/L16	●	●	32	25	250	45	23	16	12		※		MXD0513	MYB1814	
S32T-MTQNR/L16	●	●	41	32	300	54	29	22.5	17		TN-M1603				

● Stock ○ Available upon Order

- Turning inserts
- External turning
- Internal turning
- Grooving & parting
- Threading
- Milling
- Boring & drilling
- Tool holder
- Solid carbide end mills
- Solid carbide drill & taps
- Technical information

S**MTJNR/L

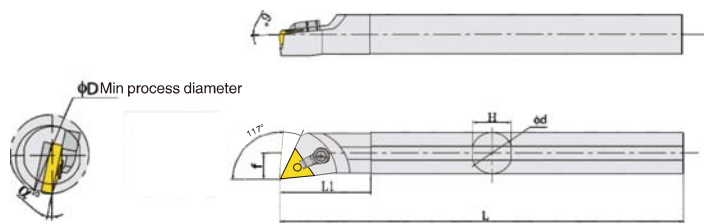

Ordering Code	Stock		Dimensions(mm)							Insert	Shim	Pin	Clamp	Screw	Wrench
	R	L	D	d	L	L1	H	f	a°						
S20Q-MTJNR/L16	●	●	25	20	180	40	18	13	15	TN**1604	※	MXD0511	MYB1811	ST0620	L2.0 L3.0
S20R-MTJNR/L16	●	●	25	20	200	40	18	13	15						
S25R-MTJNR/L16	●	●	32	25	200	45	23	16.5	12						
S25S-MTJNR/L16	●	●	32	25	250	45	23	16.5	12						
S32S-MTJNR/L16	●	●	41	32	250	54	29	22.5	17						
S32T-MTJNR/L16	●	●	41	32	300	54	29	22.5	17						
										TN-M1603	MXD0513	MYB1814	ST0625		

S**MTFNR/L

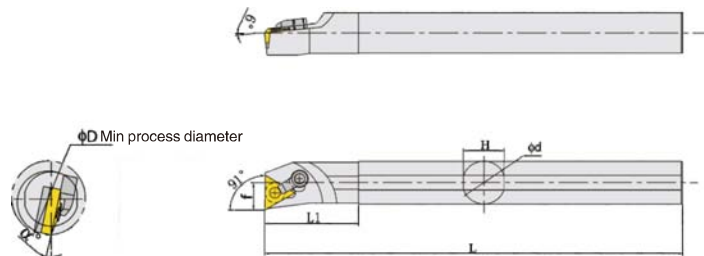

Ordering Code	Stock		Dimensions(mm)							Insert	Shim	Pin	Clamp	Screw	Wrench
	R	L	D	d	L	L1	H	f	a°						
S16Q-MTFNR/L16	●	●	20	16	180	38	15	11	15	TN**1604	※	MXD0511	MYB1811	ST0620	L2.0 L3.0
S20Q-MTFNR/L16	●	●	25	20	180	45	18	13	15						
S20R-MTFNR/L16	●	●	25	20	200	45	18	13	15						
S25R-MTFNR/L16	●	●	32	25	200	45	23	16.5	12						
S25S-MTFNR/L16	●	●	32	25	250	45	23	16.5	12						
S32S-MTFNR/L16	●	●	41	32	250	50	29	22.5	17						
S32T-MTFNR/L16	●	●	41	32	300	50	29	22.5	17	TN-M1603	MXD0513	MYB1814	ST0625		

● Stock ○ Available upon Order

Turning inserts

External turning

Internal turning

Grooving & parting

Threading

Milling

Boring & drilling

Tool holder

Solid carbide end mills

Solid carbide drill & taps

Technical information

Turning inserts

External turning

Internal turning

Grooving & parting

Threading

Milling

Boring & drilling

Tool holder

Solid carbide end mills

Solid carbide drill & taps

Technical information

S**PTUNR/L

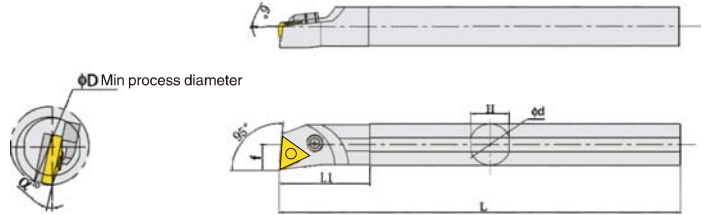

Order ng Code	Stock		Dimensions(mm)							Insert	Sh m	Lever	Shim pin	Screw	Wrench
	R	L	D	d	L	L1	H	f	a°						
S20R-PTUNR/L16	●	●	25	20	200	33	18	13	15	TN**1604	※	GGX0310A	※	NLJ0615	L2.5
S25S-PTUNR/L16	●	●	32	25	250	42	23	17	12						
S32T-PTUNR/L16	●	●	44	32	300	50	30	22	17						
S40T-PTUNR/L16	●	●	54	40	300	55	37	27	15						

S**MTUNR/L

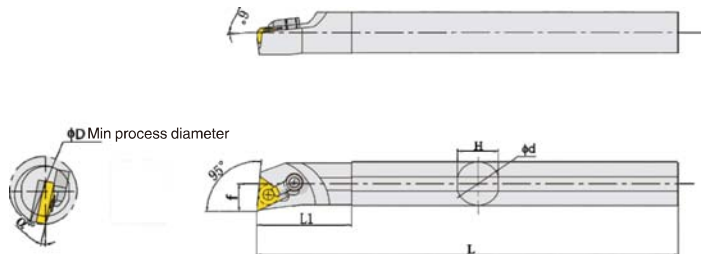

Order ng Code	Stock		Dimensions(mm)							Insert	Sh m	P n	Clamp	Screw	Wrench
	R	L	D	d	L	L1	H	f	a°						
S16Q-MTUNR/L16	○	○	20	16	180	38	15	11	15	TN**1604	※	MXD0511	MYB1811	ST0620	L2.0 L3.0
S20Q-MTUNR/L16	●	●	25	20	180	45	18	13	15						
S20R-MTUNR/L16	●	●	25	20	200	45	18	13	15						
S25R-MTUNR/L16	●	●	32	25	200	45	23	16.5	12						
S25S-MTUNR/L16	●	●	32	25	250	45	23	16.5	12						
S32S-MTUNR/L16	●	●	41	32	250	50	29	22.5	17						
S32T-MTUNR/L16	●	●	41	32	300	50	29	22.5	17						

● Stock ○ Available upon Order

S**DTUNR/L

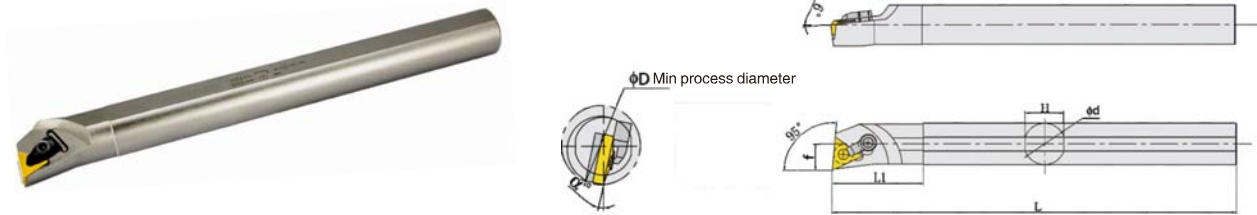

Ordering Code	Stock		Dimensions(mm)							Insert	Shim	Pin	Clamp	Screw	Wrench	Wrench
	R	L	D	d	L	L1	H	f	a°							
S20R-DTUNR/L16	●	●	25	20	200	45	18	13	15	TN**1604	※	※	DYB2313	DGD0520	DTH0814	L4.0
S25S-DTUNR/L16	●	●	32	25	250	45	23	16.5	12		TN-D1603	DXD0512				
S32T-DTUNR/L16	●	●	42	32	300	50	29	22.5	17							

S**MTWNR/L

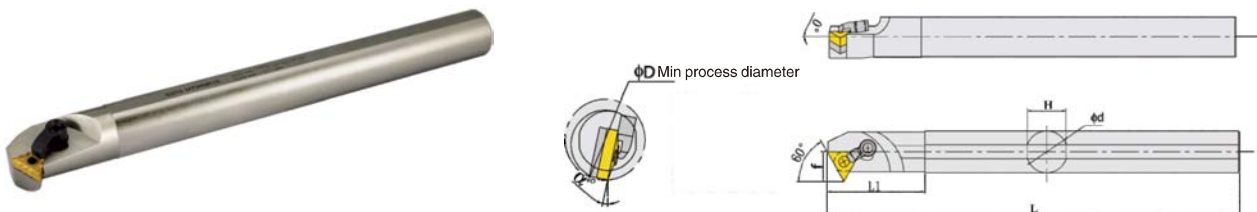

Ordering Code	Stock		Dimensions(mm)							Insert	Shim	Pin	Clamp	Screw	Wrench
	R	L	D	d	L	L1	H	f	a°						
S20R-MTWNR/L16	●	●	25	20	200	45	18	14	15	TN**1604	※	MXD0511	MYB1811	ST0622	L2.0 L3.0
S25S-MTWNR/L16	●	●	32	25	250	45	23	16	12				MXD0511	MYB1814	
S32T-MTWNR/L16	●	●	41	32	300	50	29	20	17		TN-M1603	MXD0513			

● Stock ○ Available upon Order

Turning inserts

External turning

Internal turning

Grooving & parting

Threading

Milling

Boring & drilling

Tool holder

Solid carbide end mills

Solid carbide drill & taps

Technical information

Internal turning tools

S**MWLNR/L

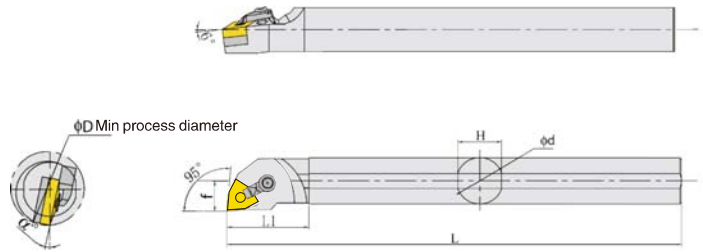

Order ng Code	Stock		Dimensions(mm)							Insert	Sh m	Lever	Clamp	Screw	Wrench			
	R	L	D	d	L	L1	H	f	a°									
S16Q-MWLNR/L06	●	●	22	16	180	38	15	11	15	WN**0604	※	MXD0511	MYB1811	ST0620	L2.0 L3.0			
S20R-MWLNR/L06	●	●	25	20	200	45	18	13	15				MYB1814	ST0625				
S25S-MWLNR/L06	●	●	32	25	250	45	23	16.5	12			WN**0804	※	MXD0614	MYB1811	ST0620	L2.0 L3.0	
S20Q-MWLNR/L08	●	●	25	20	180	45	18	13	15	WN-M0804	MXD0617				MYB1814	ST0625		
S20R-MWLNR/L08	●	●	25	20	200	45	18	13	15						MXD0617	MYB1814		ST0625
S25R-MWLNR/L08	●	●	32	25	200	45	23	16.5	12									
S25S-MWLNR/L08	●	●	32	25	250	45	23	16.5	12									
S32S-MWLNR/L08	●	●	41	32	250	50	29	22.5	17									
S32T-MWLNR/L08	●	●	41	32	300	50	29	22.5	17									
S40U-MWLNR/L08	●	●	50	40	350	55	37	26	15									

S**PWLNR/L

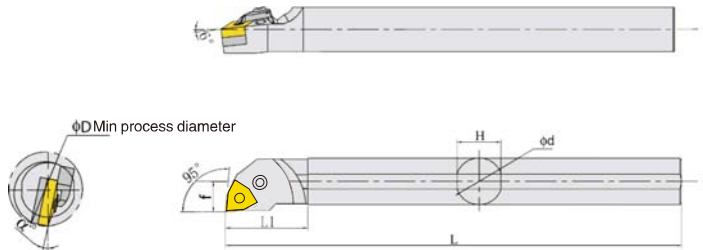

Order ng Code	Stock		Dimensions(mm)							Insert	Sh m	Lever	Sh m p n	Screw	Wrench
	R	L	D	d	L	L1	H	f	a°						
S20R-PWLNR/L06	●	●	25	20	200	45	18	13	15	WN**0604	※	GGX0310	※	NLJ0615	L3.0
S25S-PWLNR/L08	●	●	32	25	250	45	23	16.5	12			GGX0514A		NLJ0816	
S32T-PWLNR/L08	●	●	44	32	300	50	29	22.5	17	WN**0804	WN-P0803	GGX0514	DPX0606	NLJ0820	
S40T-PWLNR/L08	●	●	54	40	300	55	37	26	15						

● Stock ○ Available upon Order

Turning inserts

External turning

Internal turning

Grooving & parting

Threading

Milling

Boring & drilling

Tool holder

Solid carbide end mills

Solid carbide drill & taps

Technical information

S**DWLNR/L

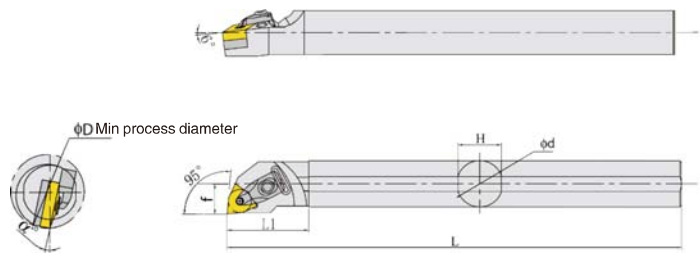

Ordering Code	Stock		Dimensions(mm)								Insert	Shim	Pin	Clamp	Screw	Wrench	Wrench
	R	L	D	d	L	L1	H	f	a°								
S20R-DWLNR/L08	●	●	25	20	200	45	18	13	15	WN**0804	※	※	DYB2214	DGD0520	DTN0814	L4.0	
S25S-DWLNR/L08	●	●	32	25	250	45	23	16.5	12								
S32T-DWLNR/L08	●	●	42	32	300	50	29	22.5	17								
S40U-DWLNR/L08	●	●	50	40	350	55	37	26	15		WN-D0804	DXD0614					

S**DVXNR/L

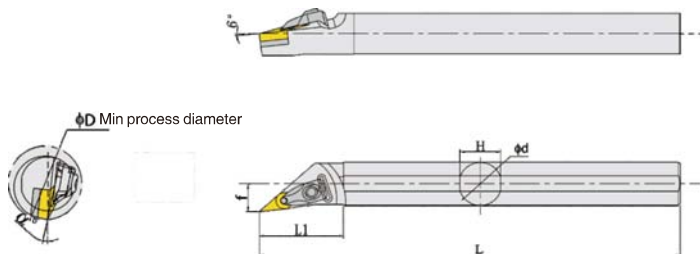

Ordering Code	Stock		Dimensions(mm)								Insert	Shim	Pin	Clamp	Screw	Wrench	Wrench
	R	L	D	d	L	L1	H	f	a°								
S20R-DVXNR/L16	●	●	27	20	200	45	18	14	15	VN**1604	※	※	DYB2914	DGD0520	DTN0814	L4.0	
S25S-DVXNR/L16	●	●	32	25	250	45	23	17	12								
S32T-DVXNR/L16	●	●	42	32	300	50	29	23	17								
S40U-DVXNR/L16	●	●	50	40	350	55	37	27	15		VN-D1603	DXD0512					

● Stock ○ Available upon Order

Turning inserts

External turning

Internal turning

Grooving & parting

Threading

Milling

Boring & drilling

Tool holder

Solid carbide end mills

Solid carbide drill & taps

Technical information

Turning inserts

External turning

Internal turning

Grooving & parting

Threading

Milling

Boring & drilling

Tool holder

Solid carbide end mills

Solid carbide drill & taps

Technical information

S**DVQNR/L

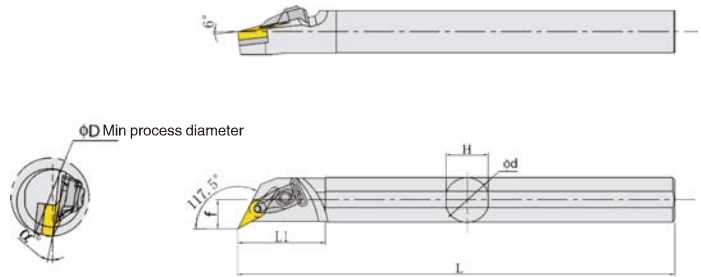

Order ng Code	Stock		Dimensions(mm)							Insert	Sh m	Pin	Clamp	Screw	Wrench	Wrench
	R	L	D	d	L	L1	H	f	a°							
S25S-DVQNR/L16	●	●	32	25	250	45	23	17	12	VN**1604	※	※	DYB2914	DGD0520	DTH0814	L4.0
S32T-DVQNR/L16	●	●	42	32	300	50	29	23	17		VN-D1603	DXD0512				
S40U-DVQNR/L16	●	●	50	40	350	55	37	27	15							

S**DVUNR/L

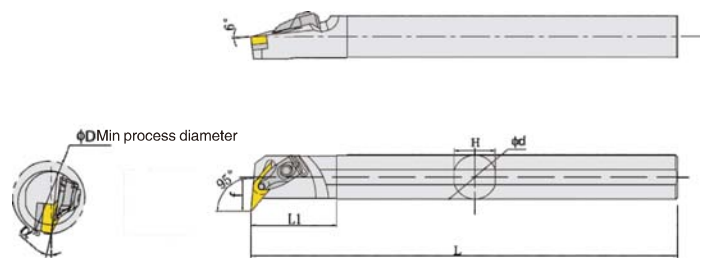

Order ng Code	Stock		Dimensions(mm)							Insert	Sh m	Pin	Clamp	Screw	Wrench	Wrench
	R	L	D	d	L	L1	H	f	a°							
S25S-DVUNR/L16	●	●	32	25	250	45	23	17	12	VN**1604	※	※	DYB2914	DGD0520	DTH0814	L4.0
S32T-DVUNR/L16	●	●	42	32	300	50	29	23	17		VN-D1603	DXD0512				
S40U-DVUNR/L16	●	●	50	40	350	55	37	27	15							

S**DVWNR/L

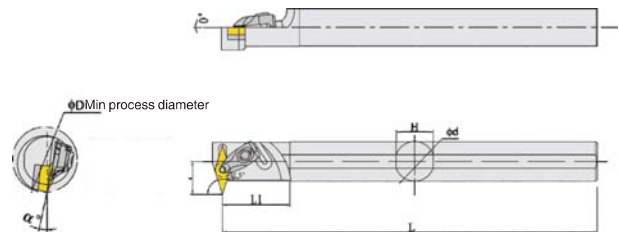

Order ng Code	Stock		Dimensions(mm)							Insert	Sh m	Pin	Clamp	Screw	Wrench	Wrench
	R	L	D	d	L	L1	H	f	a°							
S25S-DVWNR/L16	●	●	32	25	250	45	23	17	12	VN**1604	※	※	DYB2914	DGD0520	DTH0814	L4.0
S32T-DVWNR/L16	●	●	42	32	300	50	29	23	17		VN-D1603	DXD0512				

● Stock ○ Available upon Order

C**-SCLCR/L (Carbide Holder)

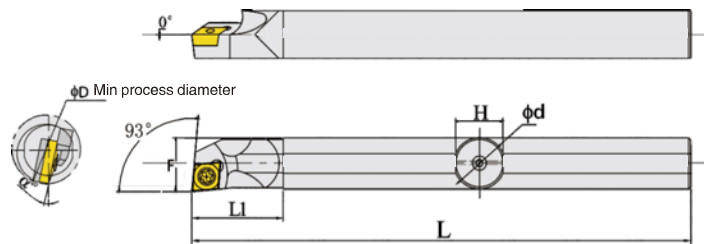

Ordering Code	Stock		Dimensions(mm)							Insert	Screw	Wrench
	R	L	D	d	L	L1	H	f	a°			
C04G-SCLCR/L03	●	○	5	4	2.5	3.8	90	15	15°	CCGT0301	M1.8*3.5	T-6
C05H-SCLCR/L03	●	○	6	5	3	4.4	100	15	13°			
C06H-SCLCR/L04	●	○	7	6	3.5	5.4	100	15	13°	CCGT0401	M2.0*4	T-6
C07K-SCLCR/L04	●	○	8	7	4	6.4	125	20	15°			
C08K-SCLCR/L06	●	○	10	8	5	7	125	20	13	CC**0602	M2.5*6	T-8
C10K-SCLCR/L06	●	○	13	10	6.5	9	125	22	12			
C12M-SCLCR/L06	●	○	16	12	8	11	150	25	10			
C12Q-SCLCR/L06	●	○	16	12	8	11	180	25	12	CC**09T3	M3.5*8	T-15
C16Q-SCLCR/L09	●	○	20	16	10	15	180	28	10			
C20S-SCLCR/L09	●	○	25	20	12.5	18	250	33	8			

C**-SCLCR/L-A (Carbide Holder)

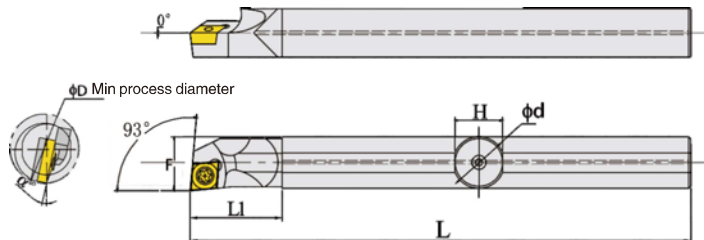

Ordering Code	Stock		Dimensions(mm)							Insert	Screw	Wrench
	R	L	D	d	L	L1	H	f	a°			
C0604G-SCLCR/L03-A	●	○	5	4	2.5	3.8	90	15	15°	CCGT0301	M1.8*3.5	T-6
C0605H-SCLCR/L03-A	●	○	6	5	3	4.4	100	15	13°			
C06H-SCLCR/L04-A	●	○	7	6	3.5	5.4	100	15	13°	CCGT0401	M2.0*4	T-6
C07K-SCLCR/L04-A	●	○	8	7	4	6.4	125	20	15°			
C08K-SCLCR/L06-A	●	○	10	8	5	7	125	20	13	CC**0602	M2.5*6	T-8
C10K-SCLCR/L06-A	●	○	13	10	6.5	9	125	22	12			
C12M-SCLCR/L06-A	●	○	16	12	8	11	150	25	10			
C12Q-SCLCR/L06-A	●	○	16	12	8	11	180	25	12	CC**09T3	M3.5*8	T-15
C16Q-SCLCR/L09-A	●	○	20	16	10	15	180	28	10			
C20S-SCLCR/L09-A	●	○	25	20	12.5	18	250	33	8			

● Stock ○ Available upon Order

Turning inserts

External turning

Internal turning

Grooving & parting

Threading

Milling

Boring & drilling

Tool holder

Solid carbide end mills

Solid carbide drill & taps

Technical information

H-SCLCR/L (HSS Holder)**

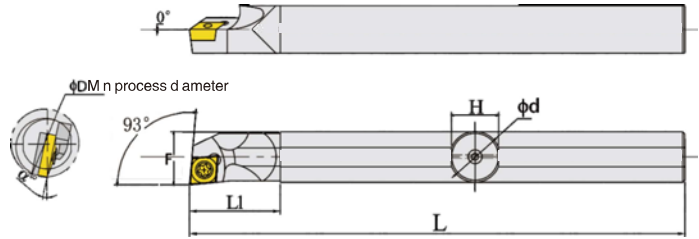

Order ng Code	Stock		Dimensions(mm)							Insert	Screw	Wrench
	R	L	D	d	L	L1	H	f	a°			
H04H-SCLCR/L03	●	○	5	4	2.5	3.8	100	15	15°	CCGT0301	M1.8*3.5	T-6
H05H-SCLCR/L03	●	○	6	5	3	4.4	100	15	13°			
H1004H-SCLCR/L03	●	○	5	10	2.5	3.8	100	15	15°	CCGT0301	M1.8*3.5	T-6
H1005H-SCLCR/L03	●	○	6	10	3	4.4	100	15	13°			
H06H-SCLCR/L04	●	○	7	6	3.5	5.4	100	15	13°	CCGT0401	M2.0*4	T-6
H07K-SCLCR/L04	●	○	8	7	4	6.4	125	20	15°			
H08K-SCLCR/L06	●	○	10	8	5	7	125	20	13	CC**0602	M2.5*6	T-8
H10K-SCLCR/L06	●	○	13	10	6.5	9	125	22	12			
H12K-SCLCR/L06	●	○	16	12	8	11	125	25	10			
H12M-SCLCR/L09	○	○	16	12	8	11	150	25	12	CC**09T3	M3.5*8	T-15

C*-SDQCR/L (Carbide Holder)**

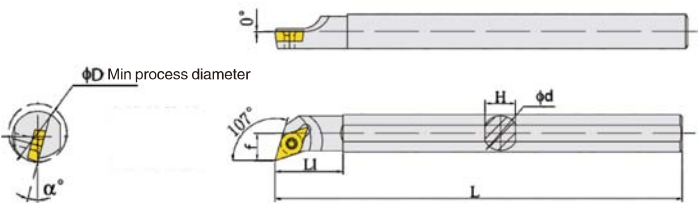

Order ng Code	Stock		Dimensions(mm)							Insert	Screw	Wrench
	R	L	D	d	L	L1	H	f	a°			
C08K-SDQCR/L07	●	○	13	8	6	7	125	20	12	DC**0702	M2.5*6	T-8
C10K-SDQCR/L07	●	○	16	10	7	9	125	23	10			
C12M-SDQCR/L07	●	○	20	12	9	11	150	30	8			
C12Q-SDQCR/L07	●	○	20	12	9	11	150	30	8			
C16Q-SDQCR/L07	●	○	25	16	10.5	15	180	30	6			
C16Q-SDQCR/L11	●	○	25	16	11	15	180	30	6	DC**11T3	M3.5*8	T-15
C16R-SDQCR/L11	●	○	25	16	11	15	200	30	6			
C20S-SDQCR/L11	●	○	28	20	12.5	18	250	39	6			

● Stock ○ Available upon Order

- Turning inserts
- External turning
- Internal turning
- Grooving & parting
- Threading
- Milling
- Boring & drilling
- Tool holder
- Solid carbide end mills
- Solid carbide drill & taps
- Technical information

C**–SDUCR/L (Carbide Holder)

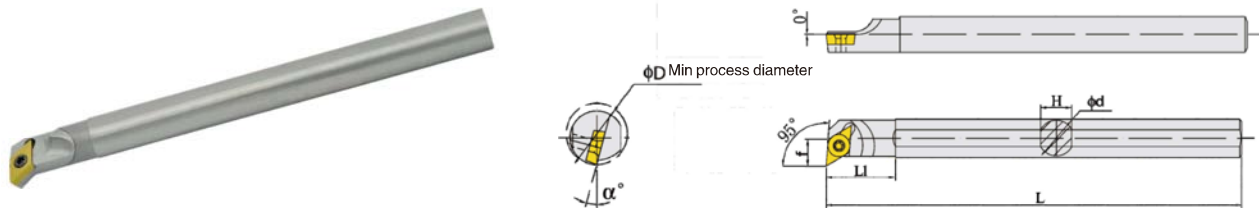

Ordering Code	Stock		Dimensions(mm)							Insert	Screw	Wrench
	R	L	D	d	L	L1	H	f	a°			
C08K–SDUCR/L07	●	○	10	8	7	13	125	25	12	DC**0702	M2.5*6	T-8
C10K–SDUCR/L07	●	○	13	10	8	12	125	25	10			
C12M–SDUCR/L07	●	○	16	12	9	10	150	28	8			
C12Q–SDUCR/L07	●	○	16	12	9	12	150	28	8			
C16Q–SDUCR/L07	●	○	20	16	11	10	180	30	6	DC**11T3	M3.5*8	T-15
C16Q–SDUCR/L11	●	○	20	16	11.5	10	180	35	6			
C16R–SDUCR/L11	●	○	20	16	11.5	10	200	35	6			
C20S–SDUCR/L11	●	○	25	20	13	8	250	40	6			

H**–SDUCR/L (HSS Holder)

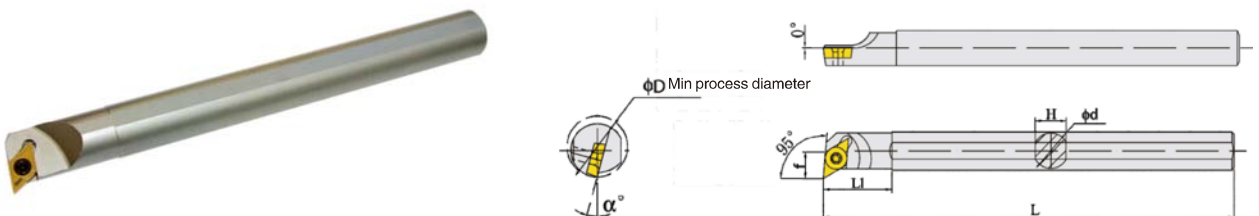

Ordering Code	Stock		Dimensions(mm)							Insert	Screw	Wrench
	R	L	D	d	L	L1	H	f	a°			
H08K–SDUCR/L07	○	○	10	8	7	13	125	25	12	DC**0702	M2.5*6	T-8
H10K–SDUCR/L07	○	○	13	10	8	12	125	25	10			
H12M–SDUCR/L07	○	○	16	12	9	10	150	28	8			
H16Q–SDUCR/L07	○	○	20	16	11	10	180	30	6			
H16Q–SDUCR/L11	○	○	20	16	11.5	10	180	35	6	DC**11T3	M3.5*8	T-15
H20R–SDUCR/L11	○	○	25	20	13	8	200	40	6			

● Stock ○ Available upon Order

Turning inserts

External turning

Internal turning

Grooving & parting

Threading

Milling

Boring & drilling

Tool holder

Solid carbide end mills

Solid carbide drill & taps

Technical information

H–SDQCR/L (HSS Holder)**

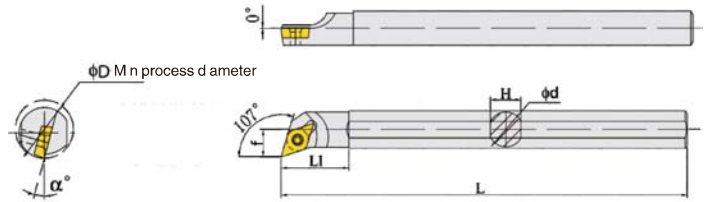

Order ng Code	Stock		Dimensions(mm)							Insert	Screw	Wrench
	R	L	D	d	L	L1	H	f	a°			
H08K–SDQCR/L07	○	○	10	8	7	13	125	25	12	DC**0702	M2.5*6	T-8
H10K–SDQCR/L07	○	○	13	10	8	12	125	25	10			
H12M–SDQCR/L07	○	○	16	12	9	10	150	28	8			
H16Q–SDQCR/L07	○	○	20	16	11	10	180	30	6			
H16Q–SDQCR/L11	○	○	20	16	11.5	10	180	35	6	DC**11T3	M3.5*8	T-15
H20R–SDQCR/L11	○	○	25	20	13	8	200	40	6			

C–STFB(C)R/L (Carbide Holder)**

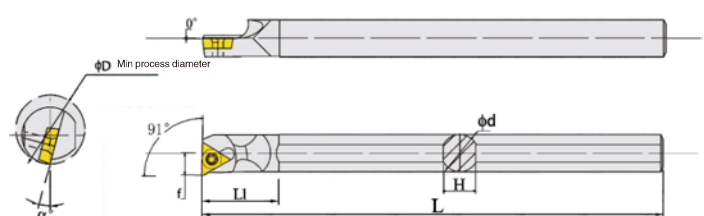

Order ng Code	Stock		Dimensions(mm)							Insert	Screw	Wrench
	R	L	D	d	d1	f	L1	L	H			
C06J–STFBR/L06	●	○	7	6	3.5	5.4	100	15	13°	TB**0601	M1.8*3.5	T-6
C07J–STFBR/L06	●	○	8	7	4	6.4	100	20	15°			
C08K–STFCR/L09	●	○	10	8	5	7	125	20	13	TC**0902	M2.0*4	T-6
C10K–STFCR/L09	●	○	13	10	6.5	9	125	22	12			
C10K–STFCR/L11	●	○	13	10	6.5	9	125	22	12	TC**1102	M2.5*6	T-8
C12M–STFCR/L11	●	○	16	12	8	11	150	25	10			
C12Q–STFCR/L11	●	○	16	12	8	11	180	25	12			
C16Q–STFCR/L11	●	○	20	16	10	15	180	28	10			
C16R–STFCR/L11	●	○	20	16	10	15	200	28	10	TC**16T3	M3.5*8	T-15
C20S–STFCR/L16	●	○	25	20	12.5	18	250	33	8			

● Stock ○ Available upon Order

Turning inserts

External turning

Internal turning

Grooving & parting

Threading

Milling

Boring & drilling

Tool holder

Solid carbide end mills

Solid carbide drill & taps

Technical information

C***-STFB(C)R/L-A (Carbide Holder)

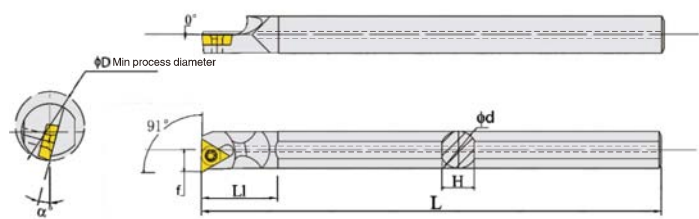

Ordering Code	Stock		Dimensions(mm)							Insert	Screw	Wrench
	R	L	D	d	d1	f	L1	L	H			
C06J-STFBR/L06-A	●	○	7	6	3.5	5.4	100	15	13°	TB**0601	M1.8*3.5	T-6
C07J-STFBR/L06-A	○	○	8	7	4	6.4	100	20	15°			
C08K-STFCR/L09-A	●	○	10	8	5	7	125	20	13	TC**0902	M2.0*4	T-6
C10K-STFCR/L09-A	●	○	13	10	6.5	9	125	22	12			
C10K-STFCR/L11-A	●	○	13	10	6.5	9	125	22	12	TC**1102	M2.5*6	T-8
C12M-STFCR/L11-A	●	○	16	12	8	11	150	25	10			
C12Q-STFCR/L11-A	●	○	16	12	8	11	180	25	12	TC**1102	M2.5*6	T-8
C16Q-STFCR/L11-A	●	○	20	16	10	15	180	28	10			
C16R-STFCR/L11-A	●	○	20	16	10	15	200	28	10	TC**16T3	M3.5*8	T-15
C20S-STFCR/L16-A	●	○	25	20	12.5	18	250	33	8			

H**-STUB(C)R/L (HSS Holder)

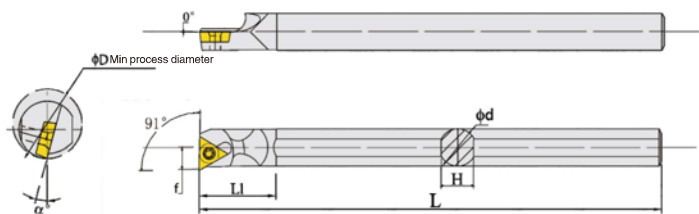

Ordering Code	Stock		Dimensions(mm)							Insert	Screw	Wrench
	R	L	D	d	d1	f	L1	L	H			
H06H-STUBR/L06	●	○	7	6	3.5	5.4	100	15	13°	TB**0601	M1.8*3.5	T-6
H07H-STUBR/L06	●	○	8	7	4	6.4	100	20	15°			
H1006K-STUBR06	●	○	7	10	3.5	5.4	100	20	13°	TC**0902	M2.0*4	T-6
H1007K-STUBR06	●	○	8	10	4	6.4	100	20	15°			
H08K-STUCR/L09	○	○	10	8	5	7	125	20	13	TC**0902	M2.0*4	T-6
H10K-STUCR/L09	○	○	13	10	6.5	9	125	22	12			
H10K-STUCR/L11	○	○	13	10	6.5	9	125	22	12	TC**1102	M2.5*6	T-8
H12M-STUCR/L11	○	○	16	12	8	11	150	25	10			
H16Q-STUCR/L11	○	○	20	16	10	15	180	28	10	TC**16T3	M3.5*8	T-15
H20R-STUCR/L16	○	○	25	20	12.5	18	200	33	8			

● Stock ○ Available upon Order

Turning inserts

External turning

Internal turning

Grooving & parting

Threading

Milling

Boring & drilling

Tool holder

Solid carbide end mills

Solid carbide drill & taps

Technical information

C**-STUB(C)R/L (Carb de Holder)

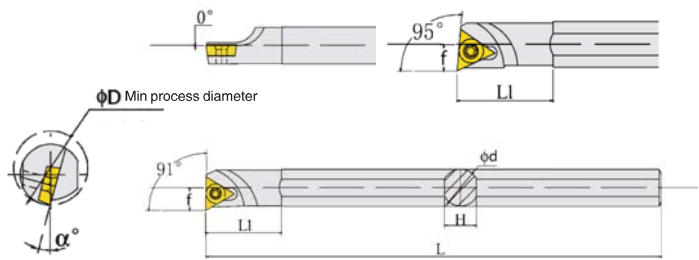

Order ng Code	Stock		Dimensions(mm)							Insert	Screw	Wrench
	R	L	D	d	d1	f	L1	L	H			
C06J-STUBR/L06	●	○	7	6	3.5	5.4	100	15	13°	TB**0601	M1.8*3.5	T-6
C07J-STUBR/L06	●	○	8	7	4	6.4	100	20	15°			
C08K-STUCR/L09	●	○	10	8	5	7	125	20	13	TC**0902	M2.0*4	T-6
C10K-STUCR/L09	●	○	13	10	6.5	9	125	22	12			
C10K-STUCR/L11	●	○	13	10	6.5	9	125	22	12	TC**1102	M2.5*6	T-8
C12M-STUCR/L11	●	○	16	12	8	11	150	25	10			
C12Q-STUCR/L11	○	○	16	12	8	11	180	25	12			
C16Q-STUCR/L11	●	○	20	16	10	15	180	28	10			
C16R-STUCR/L11	●	○	20	16	10	15	200	28	10	TC**16T3	M3.5*8	T-15
C20S-STUCR/L16	●	○	25	20	13	18	250	33	8			

C**-STUB(C)R/L-A (Carb de Holder)

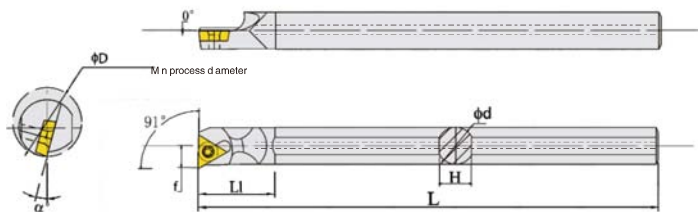

Order ng Code	Stock		Dimensions(mm)							Insert	Screw	Wrench
	R	L	D	d	d1	f	L1	L	H			
C06J-STUBR/L06-A	●	○	7	6	3.5	5.4	100	15	13°	TB**0601	M1.8*3.5	T-6
C07J-STUBR/L06-A	○	○	8	7	4	6.4	100	20	15°			
C08K-STUCR/L09-A	●	○	10	8	5	7	125	20	13	TC**0902	M2.0*4	T-6
C10K-STUCR/L09-A	●	○	13	10	6.5	9	125	22	12			
C10K-STUCR/L11-A	●	○	13	10	6.5	9	125	22	12	TC**1102	M2.5*6	T-8
C12M-STUCR/L11-A	●	○	16	12	8	11	150	25	10			
C12Q-STUCR/L11-A	○	○	16	12	8	11	180	25	12			
C16Q-STUCR/L11-A	●	○	20	16	10	15	180	28	10			
C16R-STUCR/L11-A	●	○	20	16	10	15	200	28	10	TC**16T3	M3.5*8	T-15
C20S-STUCR/L16-A	●	○	25	20	12.5	18	250	33	8			

● Stock ○ Available upon Order

C**–STUPR/L (Carbide Holder)

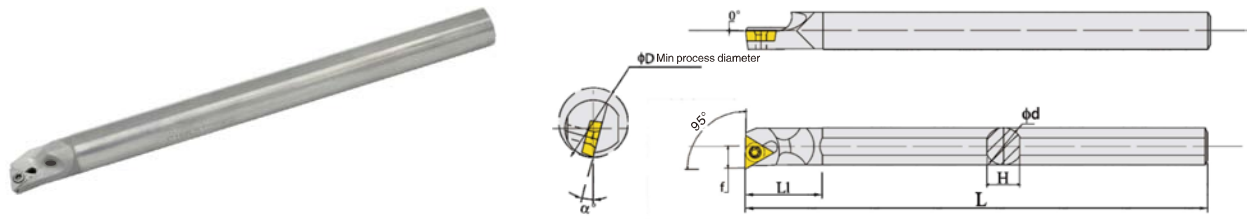

Ordering Code	Stock		Dimensions(mm)							Insert	Screw	Wrench
	R	L	D	d	d1	f	L1	L	H			
C08K–STUPR/L09	●	○	10	8	5	7	125	20	13	TP**0903	M2.0*4	T-6
C10K–STUPR/L09	●	○	13	10	6.5	9	125	22	12			
C10K–STUPR/L11	●	○	13	10	6.5	9	125	22	12	TP**1103	M2.5*6	T-8
C12M–STUPR/L11	●	○	16	12	8	11	150	25	10			
C12Q–STUPR/L11	●	○	16	12	8	11	180	25	12			
C16Q–STUPR/L11	●	○	20	16	10	15	180	28	10			
C16R–STUPR/L11	●	○	20	16	10	15	200	28	10			
C20R–STUPR/L16	●	○	25	20	13	18	200	33	8	TP**1603	M3.5*8	T-15
C20S–STUPR/L16	●	○	25	20	13	18	250	33	8			

C**–STUPR/L–A (Carbide Holder) —Coolant through center

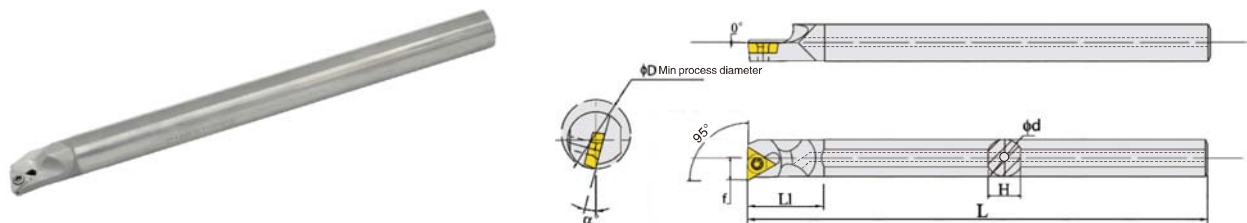

Ordering Code	Stock		Dimensions(mm)							Insert	Screw	Wrench
	R	L	D	d	d1	f	L1	L	H			
C08K–STUPR/L09–A	●	○	10	8	5	7	125	20	13	TP**0903	M2.0*4	T-6
C10K–STUPR/L09–A	●	○	13	10	6.5	9	125	22	12			
C10K–STUPR/L11–A	●	○	13	10	6.5	9	125	22	12	TP**1103	M2.5*6	T-8
C12M–STUPR/L11–A	●	○	16	12	8	11	150	25	10			
C12Q–STUPR/L11–A	●	○	16	12	8	11	180	25	12			
C16Q–STUPR/L11–A	●	○	20	16	10	15	180	28	10			
C16R–STUPR/L11–A	●	○	20	16	10	15	200	28	10			
C20R–STUPR/L16–A	●	○	25	20	13	18	200	33	8	TP**1603	M3.5*8	T-15
C20S–STUPR/L16–A	●	○	25	20	13	18	250	33	8			

● Stock ○ Available upon Order

Turning inserts

External turning

Internal turning

Grooving & parting

Threading

Milling

Boring & drilling

Tool holder

Solid carbide end mills

Solid carbide drill & taps

Technical information

H–STUPR/L (HSS Holder)**

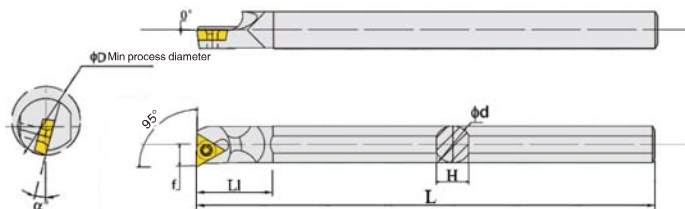

Order ng Code	Stock		Dimensions(mm)							Insert	Screw	Wrench
	R	L	D	d	d1	f	L1	L	H	a°		
H08K–STUPR09	○	○	10	8	5	7	125	20	13	TP**0903		T–6
H10K–STUPR09	○	○	13	10	6.5	9	125	22	12			
H10K–STUPR11	○	○	13	10	6.5	9	125	22	12			
H12M–STUPR11	○	○	16	12	8	11	150	25	10	TP**1103		T–8
H12Q–STUPR11	○	○	16	12	8	11	180	25	12			
H16Q–STUPR11	○	○	20	16	10	15	180	28	10			
H16R–STUPR11	○	○	20	16	10	15	200	28	10			
H20R–STUPR16	○	○	25	20	13	18	200	33	8	TP**1603		T–15
H20S–STUPR16	○	○	25	20	13	18	250	33	8			

C–SWUBR/L (Carb de Holder)**

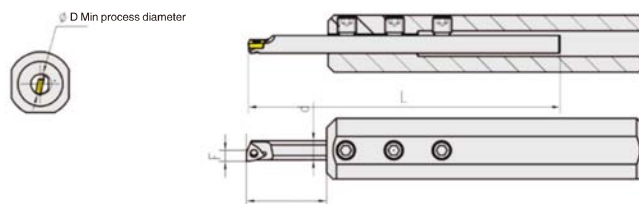

Order ng Code	Stock		Dimensions(mm)							Insert	Screw	Wrench
	R	L	D	d	F	H	L	L1	a°			
C05H–SWUBR06	●	○	6	5	3	4.4	100	15	13°	WB**0601		T–6
C06J–SWUBR06	●	○	7	6	3.5	5.4	110	15	13°			
C07J–SWUBR06	●	○	8	7	4	6.4	110	15	13°			

● Stock ○ Available upon Order

- Turning inserts
- External turning
- Internal turning
- Grooving & parting
- Threading
- Milling
- Boring & drilling
- Tool holder
- Solid carbide end mills
- Solid carbide drill & taps
- Technical information

C**–SWUBR/L–A (Carbide Holder)

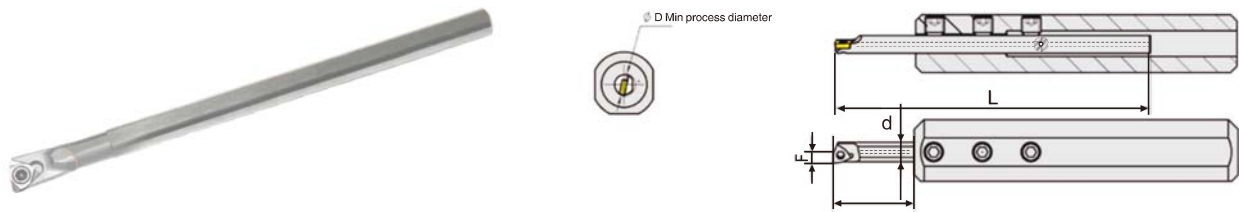

Ordering Code	Stock		Dimensions(mm)							Insert	Screw	Wrench
	R	L	D	d	F	H	L	L1	a°			
C05H–SWUBR06–A	●	○	6	5	3	4.4	100	15	13°	WB**0601	M2.0*4	T-6
C06J–SWUBR06–A	●	○	7	6	3.5	5.4	110	15	13°			
C07J–SWUBR06–A	●	○	8	7	4	6.4	110	15	13°			

H**–SWUBR/L (HSS Holder)

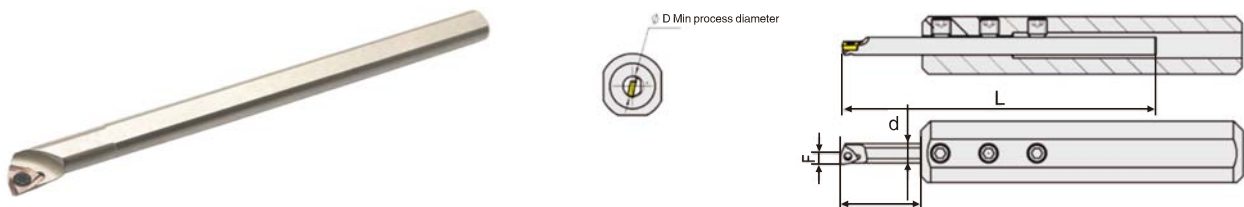

Ordering Code	Stock		Dimensions(mm)							Insert	Screw	Wrench
	R	L	D	d	F	H	L	L1	a°			
H05H–SWUBR06	●	○	6	5	3	4.4	100	15	13°	WB**0601	M2.0*4	T-6
H06H–SWUBR06	●	○	7	6	3.5	5.4	110	15	13°			
H07H–SWUBR06	●	○	8	7	4	6.4	110	15	13°			
H1005K–SWUBR06	●	○	6	10	3	4.4	100	15	13°	WB**0601	M2.0*4	T-6
H1006K–SWUBR06	●	○	7	10	3.5	5.4	110	15	13°			
H1007K–SWUBR06	●	○	8	10	4	6.4	110	15	13°			

● Stock ○ Available upon Order

Turning inserts

External turning

Internal turning

Grooving & parting

Threading

Milling

Boring & drilling

Tool holder



Solid carbide end mills

Solid carbide drill & taps

Technical information

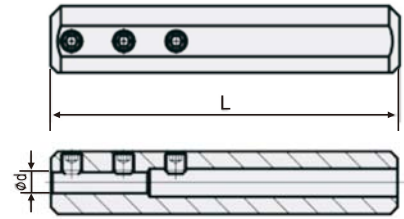
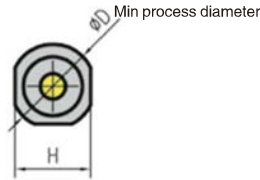

SHB Cutter

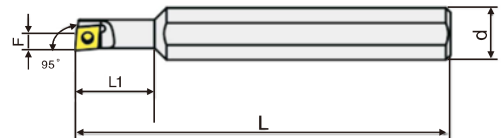

Order ng Code	Stock		Dimensions(mm)				Screw	Wrench
			D	d	L	H		
SHB 0416-100	●		16	4	100	15	ES40	L2.0
SHB 0516-100	●		16	5	100	15		
SHB 0616-100	●		16	6	100	15		
SHB 0716-100	●		16	7	100	15		
SHB 0816-100	●		16	8	100	15		
SHB 0420-100	●		20	4	100	18		
SHB 0520-100	●		20	5	100	18		
SHB 0620-100	●		20	6	100	18		
SHB 0820-100	●		20	8	100	18	ES50	L3.0
SH B1020-100	●		20	10	100	18		

S**-SCLCR/L



Order ng Code	Stock		Dimensions(mm)								Insert	Screw	Wrench			
	R	L	D	d	d1	f	L1	L	H	a°						
S0612K-SCLCR/L04	●	○	7	12	6	3.5	18	125	11	10	CC**0401	M2.0*4	T-6			
S0812K-SCLCR/L06	●	○	10	12	8	5	24	125	11	10	CC**0602	M2.5*6	T-8			
S0616M-SCLCR/L04	●	○	7	16	6	3.5	18	150	11	10	CC**0602	M2.5*6	T-8			
S0816M-SCLCR/L06	●	○	10	16	8	5	24	150	15	10						
S1016M-SCLCR/L06	●	○	13	16	10	6	30	150	15	10						
S1216M-SCLCR/L06	●	○	16	16	12	7	36	150	15	10						
S1020M-SCLCR/L06	●	○	13	20	10	6	30	150	18	8						
S1220M-SCLCR/L06	●	○	16	20	12	7	36	150	18	8						
S1220M-SCLCR/L09	●	○	16	20	12	7.5	36	150	18	8				CC**09T3	M3.5*8	T-15

● Stock ○ Available upon Order

S**-SCLCR/L

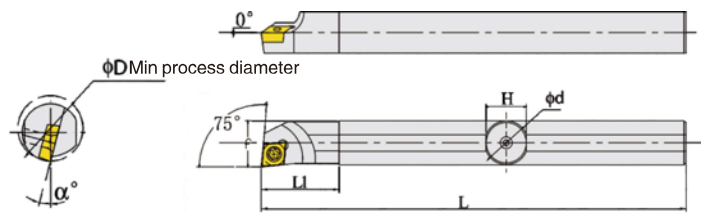

Ordering Code	Stock		Dimensions(mm)							Insert	Screw	Wrench
	R	L	D	d	f	L	L1	H	a°			
S08K-SCLCR/L06	●	●	10	8	5	125	20	7	13	CC**0602	M2.5*6	T-8
S10K-SCLCR/L06	●	●	13	10	6	125	22	9	12			
S12M-SCLCR/L06	●	●	16	12	7	150	25	11	10			
S16Q-SCLCR/L09	●	●	20	16	9.5	160	30	15	10	CC**09T3	M3.5*8	T-15
S20R-SCLCR/L09	●	●	25	20	11.5	200	35	18	8			
S25R-SCLCR/L09	●	●	31	25	14	200	35	23	6			
S25S-SCLCR/L09	●	●	31	25	14	250	40	23	6			
S25S-SCLCR/L12	●	●	31	25	14.5	250	40	23	6	CC**1204	M5.0*12	T-20
S32S-SCLCR/L12	●	●	39	32	18	250	45	29	4			
S32T-SCLCR/L12	●	●	39	32	18	300	45	29	4			

S**-SCKCR/L

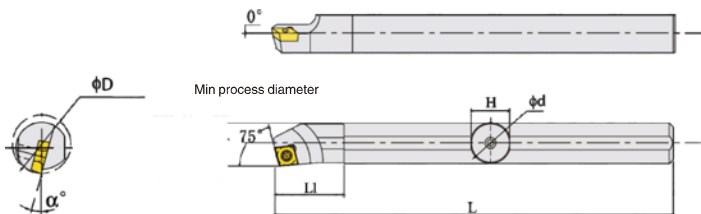

Ordering Code	Stock		Dimensions(mm)							Insert	Screw	Wrench
	R	L	D	d	f	L	L1	H	a°			
S08K-SCKCR/L06	●	●	10	8	5.5	125	20	7	13	CC**0602	M2.5*6	T-8
S10K-SCKCR/L06	●	●	13	10	6	125	22	9	12			
S12M-SCKCR/L06	●	●	16	12	7	150	25	11	10			
S16Q-SCKCR/L09	●	●	20	16	9.5	180	30	15	10	CC**09T3	M3.5*8	T-15
S20Q-SCKCR/L09	●	●	25	20	11.5	180	35	18	8			
S20R-SCKCR/L09	●	●	31	25	11.5	200	35	18	6			
S25R-SCKCR/L09	●	●	31	25	14	200	35	23	6			
S25S-SCKCR/L09	●	●	31	25	14	250	40	23	6			

● Stock ○ Available upon Order

Turning inserts

External turning

Internal turning

Grooving & parting

Threading

Milling

Boring & drilling

Tool holder

Solid carbide end mills

Solid carbide drill & taps

Technical information

S**-SCZCR/L

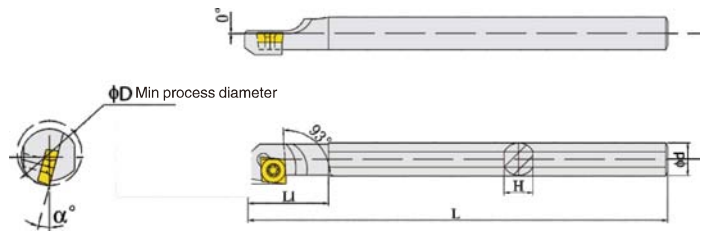

Order ng Code	Stock		Dimensions(mm)							Insert	Screw	Wrench
	R	L	D	d	f	L	L1	H	a°			
S08K-SCZCR/L06	●	●	12.5	8	6.5	125	26	7	13	CC**0602	M2.5*6	T-8
S10K-SCZCR/L06	●	●	14	10	7.5	125	28	9	12			
S12M-SCZCR/L06	●	●	16	12	8.5	150	32	11	10			
S16Q-SCZCR/L09	●	●	20	16	10.5	180	28	15	10	CC**09T3	M3.5*8	T-15
S20R-SCZCR/L09	●	●	25	20	13.5	200	40	18	8			
S25S-SCZCR/L09	●	●	32	25	16	250	45	23	6			

S**-SDQCR/L

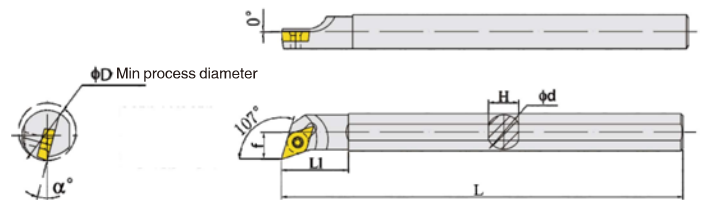

Order ng Code	Stock		Dimensions(mm)							Insert	Screw	Wrench
	R	L	D	d	f	L	L1	H	a°			
S08K-SDQCR/L07	●	●	13	8	6	125	20	7	13	DC**0702	M2.5*6	T-8
S10K-SDQCR/L07	●	●	16	10	7	125	23	9	12			
S12M-SDQCR/L07	●	●	20	12	9	150	30	11	10			
S16Q-SDQCR/L11	●	●	25	16	11	180	30	15	10	DC**11T3	M3.5*8	T-15
S20Q-SDQCR/L11	●	●	28	20	13	180	39	18	8			
S20R-SDQCR/L11	●	●	38	20	13	200	39	18	8			
S25R-SDQCR/L11	●	●	33	25	16	200	40	23	6			
S25S-SDQCR/L11	●	●	33	25	16	250	40	23	6			
S32S-SDQCR/L11	●	●	41	32	20	250	43	29	4			
S32T-SDQCR/L11	●	●	41	32	20	300	43	29	4			

● Stock ○ Available upon Order

Turning inserts

External turning

Internal turning

Grooving & parting

Threading

Milling

Boring & drilling

Tool holder

Solid carbide end mills

Solid carbide drill & taps

Technical information

S**-SDUCR/L

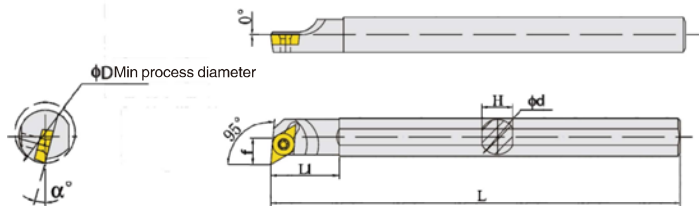

Ordering Code	Stock		Dimensions(mm)							Insert	Screw	Wrench
	R	L	D	d	f	L	L1	H	a°			
S08K-SDUCR/L07	●	●	13	8	7	125	25	9	13	DC**0702	M2.5*6	T-8
S10K-SDUCR/L07	●	●	15	10	8	125	25	9	12			
S12M-SDUCR/L07	●	●	17	12	9	150	28	11	10			
S16Q-SDUCR/L11	●	●	23	16	11.5	180	30	15	10	DC**11T3	M3.5*8	T-15
S20Q-SDUCR/L11	●	●	25	20	13	180	35	18	8			
S20R-SDUCR/L11	●	●	25	20	13	200	35	18	8			
S25R-SDUCR/L11	●	●	32	25	16	200	40	23	6			
S25S-SDUCR/L11	●	●	32	25	16	250	40	23	6			
S32S-SDUCR/L11	●	●	39	32	20	250	45	29	4			
S32T-SDUCR/L11	●	●	39	32	20	300	45	29	4			

S**-SDZCR/L

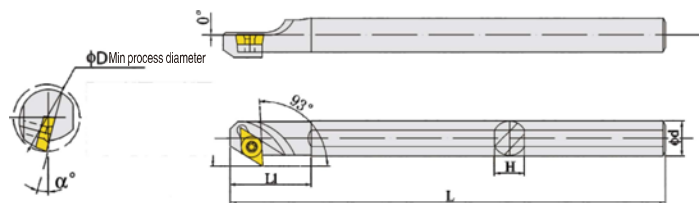

Ordering Code	Stock		Dimensions(mm)							Insert	Screw	Wrench
	R	L	D	d	f	L	L1	H	a°			
S10K-SDZCR/L07	●	●	16	10	8	125	28	9	12	DC**0702	M2.5*6	T-8
S12M-SDZCR/L07	●	●	18	12	9	150	30	11	10			
S16Q-SDZCR/L07	●	●	22	16	11	180	30	15	10			
S16Q-SDZCR/L11	●	●	24	16	12	180	35	15	10	DC**11T3	M3.5*8	T-15
S20R-SDZCR/L11	●	●	28	20	13	200	40	18	8			
S25S-SDZCR/L11	●	●	34	25	16	250	45	23	6			
S32T-SDZCR/L11	●	●	38	32	20.5	300	50	29	4			

● Stock ○ Available upon Order

Turning inserts

External turning

Internal turning

Grooving & parting

Threading

Milling

Boring & drilling

Tool holder



Solid carbide end mills

Solid carbide drill & taps

Technical information

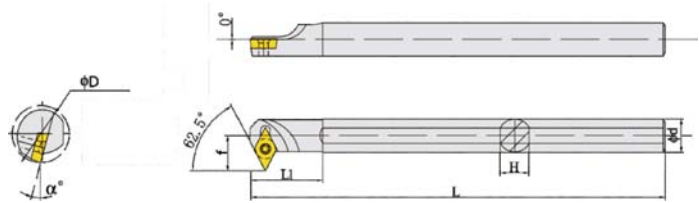

S**–SDWCR/L

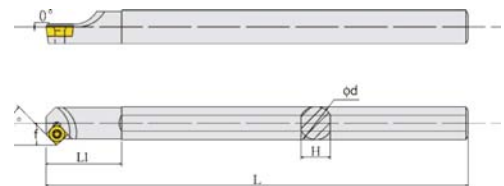

Order ng Code	Stock		Dimensions(mm)							Insert	Screw	Wrench
	R	L	D	d	f	L	L1	H	α°			
S10K–SDWCR/L07	●	●	16	10	8	125	28	9	12	DC**0702	M2.5*6	T-8
S12M–SDWCR/L07	●	●	18	12	9	150	30	11	10			
S16Q–SDWCR/L07	●	●	22	16	11	180	30	15	10			
S16Q–SDWCR/L11	●	●	24	16	12	180	35	15	10	DC**11T3	M3.5*8	T-15
S20R–SDWCR/L11	●	●	28	20	13	200	40	18	8			
S25S–SDWCR/L11	●	●	34	25	16	250	45	23	6			
S32T–SDWCR/L11	●	●	38	32	20.5	300	50	29	4			

S**–SSSCR/L



Order ng Code	Stock		Dimensions(mm)							Insert	Screw	Wrench
	R	L	D	d	f	L	L1	H	α°			
S12M–SSSCR/L09	●	●	16	12	8.5	150	30	11	12	SC**09T3	M3.5*8	T-15
S16Q–SSSCR/L09	●	●	22	16	11.5	180	35	15	10			
S20R–SSSCR/L09	●	●	26	20	13.5	200	40	18	8			
S25S–SSSCR/L09	●	●	31	25	16	250	40	23	6	SC**1204	M5*12	T-20
S20R–SSSCR/L12	●	●	26	20	14	200	40	15	8			
S25S–SSSCR/L12	●	●	31	25	16.5	250	40	23	6			

● Stock ○ Available upon Order

S**-SSKCR/L

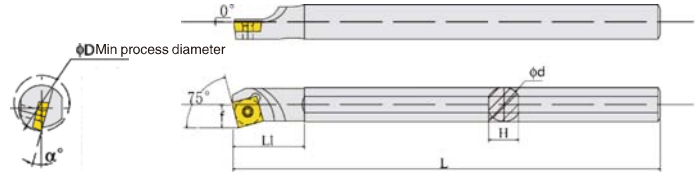

Ordering Code	Stock		Dimensions(mm)							Insert	Screw	Wrench
	R	L	D	d	f	L	L1	H	a°			
S12M-SSKCR/L09	●	●	16	12	8.5	150	30	11	12	SC**09T3	M3.5*8	T-15
S16Q-SSKCR/L09	●	●	22	16	11.5	180	35	15	10			
S20R-SSKCR/L09	●	●	26	20	13.5	200	40	18	8			
S25S-SSKCR/L09	●	●	31	25	16	250	40	23	6			
S20R-SSKCR/L12	●	●	26	20	14	200	40	15	8	SC**1204	M5*12	T-20
S25S-SSKCR/L12	●	●	31	25	16.5	250	40	23	6			

S**-STFCR/L

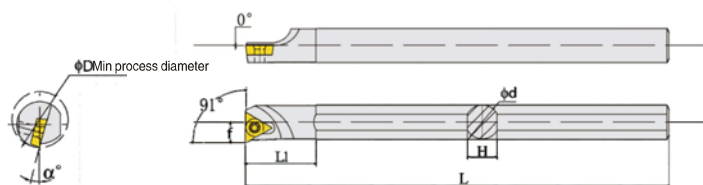

Ordering Code	Stock		Dimensions(mm)							Insert	Screw	Wrench
	R	L	D	d	f	L	L1	H	a°			
S10K-STFCR/L09	●	●	13	10	5	125	24	9	13	TC**0902	M2.2*6	T-6
S12M-STFCR/L09	●	●	16	12	7	150	27	11	10			
S10K-STFCR/L11	●	●	13	10	5	125	24	9	13	TC**1102	M2.5*6	T-8
S12M-STFCR/L11	●	●	16	12	7	150	27	11	10			
S16Q-STFCR/L11	●	●	20	16	9	180	30	15	8			
S20R-STFCR/L11	●	●	25	20	11	200	35	18	6			
S20R-STFCR/L16	●	●	25	20	11.5	200	40	18	8	TC**16T3	M3.5*8	T-15
S25S-STFCR/L16	●	●	31	25	14	250	40	23	4			
S32T-STFCR/L16	●	●	39	32	17.5	300	45	29	4			

● Stock ○ Available upon Order

Turning inserts

External turning

Internal turning

Grooving & parting

Threading

Milling

Boring & drilling

Tool holder

Solid carbide end mills

Solid carbide drill & taps

Technical information

S-STUCR/L**

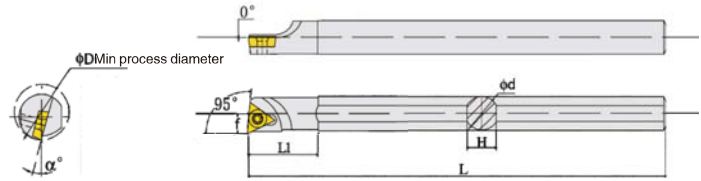

Order ng Code	Stock		Dimensions(mm)							Insert	Screw	Wrench
	R	L	D	d	f	L	L1	H	a°			
S06H-STUCR/L06	●	●	8	6	3.5	100	15	5	15	TB**0601	M1.8*3	T-6
S08K-STUCR/L09	●	●	10.5	8	5	125	23	7	15			
S10K-STUCR/L09	●	●	13	10	6	125	24	9	13			
S12M-STUCR/L09	●	●	16	12	7	150	27	11	10	TC**1102	M2.2*6	T-6
S12M-STUCR/L11	●	●	16	12	7	150	27	11	10			
S16Q-STUCR/L11	●	●	20	16	9	180	30	15	8			
S20R-STUCR/L11	●	●	25	20	11	200	35	18	6	TC**16T3	M3.5*8	T-15
S20R-STUCR/L16	●	●	25	20	11.5	200	40	18	8			
S25S-STUCR/L16	●	●	31	25	14	250	40	23	4			
S32T-STUCR/L16	●	●	39	32	17.5	300	45	29	4			

S-STWCR/L**

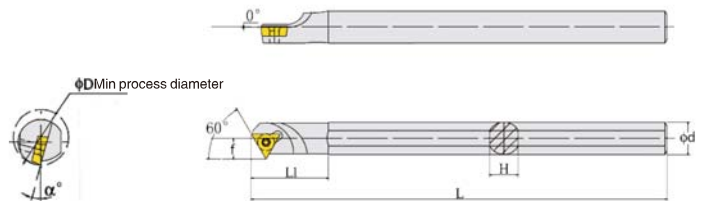

Order ng Code	Stock	Dimensions(mm)							Insert	Screw	Wrench
		D	d	f	L	L1	H	a°			
S08K-STWCR/L09	●	10.5	8	5	125	23	7	15	TC**0902	M2.2*6	T-6
S10K-STWCR/L09	●	13	10	6	125	24	9	13			
S10K-STWCR/L11	●	13	10	5	125	24	9	13			
S12M-STWCR/L11	●	16	12	7	150	27	11	10	TC**1102	M2.5*6	T-8
S14N-STWCR/L11	●	18	14	7	160	30	13	10			
S16Q-STWCR/L11	●	20	16	9	180	30	15	8			
S20R-STWCR/L16	●	25	20	11.5	200	40	18	8	TC**16T3	M3.5*8	T-15
S25S-STWCR/L16	●	31	25	14	250	40	23	4			

● Stock ○ Available upon Order

- Turning inserts
- External turning
- Internal turning
- Grooving & parting
- Threading
- Milling
- Boring & drilling
- Tool holder
- Solid carbide end mills
- Solid carbide drill & taps
- Technical information

S** -SVQB(C)R/L

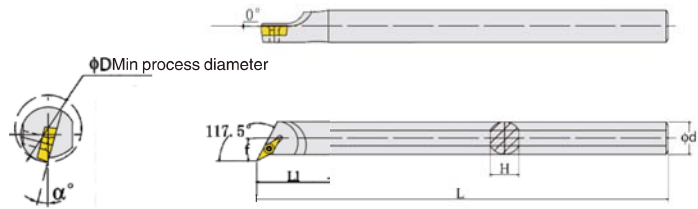

Ordering Code	Stock		Dimensions(mm)							Insert	Screw	Wrench
	R	L	D	d	f	L	L1	H	a°			
S16Q-SVQB(C)R/L11	●	●	22	16	11.5	180	35	15	12	VB**1103	M2.5*6	T-8
S20R-SVQB(C)R/L11	●	●	27	20	14	200	39	18	12			
S20R-SVQB(C)R/L16	●	●	27	20	14	200	50	18	12	VB**1604	M3.5*8	T-15
S25S-SVQB(C)R/L16	●	●	32	25	16.5	250	50	23	8			
S32T-SVQB(C)R/L16	●	●	41	32	22.5	300	55	29	8			
S16Q-SVQCR/L11	●	●	22	16	11.5	180	35	15	8	VC**1103	M2.5*6	T-8
S20R-SVQCR/L11	●	●	27	20	14	200	39	18	6			
S20R-SVQCR/L16	●	●	27	20	14	200	50	18	8	VC**1604	M3.5*8	T-15
S25S-SVQCR/L16	●	●	32	25	16.5	250	50	23	6			
S32T-SVQCR/L16	●	●	41	32	22.5	300	55	29	8			

S** -SVUCR/L

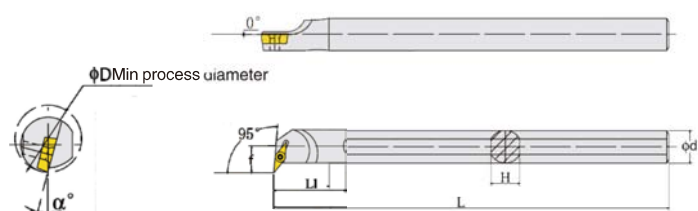

Ordering Code	Stock		Dimensions(mm)							Insert	Screw	Wrench
	R	L	D	d	f	L	L1	H	a°			
S16Q-SVUBR/L11	●	●	22	16	11.5	180	35	15	12	VB**1103	M2.5*6	T-8
S20R-SVUBR/L11	●	●	27	20	14	200	39	18	12			
S20R-SVUBR/L16	●	●	27	20	14	200	50	18	12	VB**1604	M3.5*8	T-15
S25S-SVUBR/L16	●	●	32	25	16.5	250	50	23	8			
S32T-SVUBR/L16	●	●	41	32	22.5	300	55	29	8			
S16Q-SVUCR/L11	●	●	22	16	11.5	180	35	15	8	VC**1103	M2.5*6	T-8
S20R-SVUCR/L11	●	●	27	20	14	200	39	18	6			
S20R-SVUCR/L16	●	●	27	20	14	200	50	18	8	VC**1604	M3.5*8	T-15
S25S-SVUCR/L16	●	●	32	25	16.5	250	50	23	6			
S32T-SVUCR/L16	●	●	41	32	22.5	300	55	29	8			

● Stock ○ Available upon Order

Turning inserts

External turning

Internal turning

Grooving & parting

Threading

Milling

Boring & drilling

Tool holder

Solid carbide end mills

Solid carbide drill & taps

Technical information

S** -SVXB(C)R/L

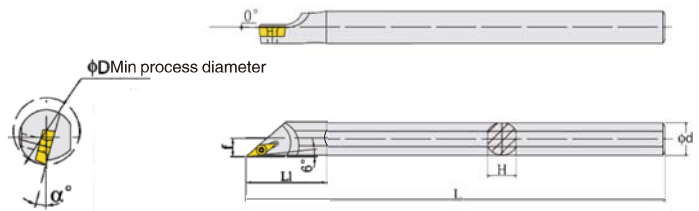

Order ng Code	Stock		Dimensions(mm)							Insert	Screw	Wrench
	R	L	D	d	f	L	L1	H	a°			
S16Q-SVXBR/L11	●	●	20	16	9.5	180	35	15	12	VB**1103	M2.5*6	T-8
S20R-SVXBR/L11	●	●	23	20	11.5	200	39	18	12			
S20R-SVXBR/L16	●	●	23	20	11.5	200	50	18	12	VB**1604	M3.5*8	T-15
S25S-SVXBR/L16	●	●	30	25	14	250	50	23	8			
S32T-SVXBR/L16	●	●	35	32	17.5	300	55	29	8			
S16Q-SVXCR/L11	●	●	20	16	9.5	180	35	15	8	VC**1103	M2.5*6	T-8
S20R-SVXCR/L11	●	●	23	20	11.5	200	39	18	6			
S20R-SVXCR/L16	●	●	23	20	11.5	200	50	18	8	VC**1604	M3.5*8	T-15
S25S-SVXCR/L16	●	●	30	25	14	250	50	23	6			
S32T-SVXCR/L16	●	●	35	32	17.5	300	55	29	8			

S** -SVZB(C)R/L

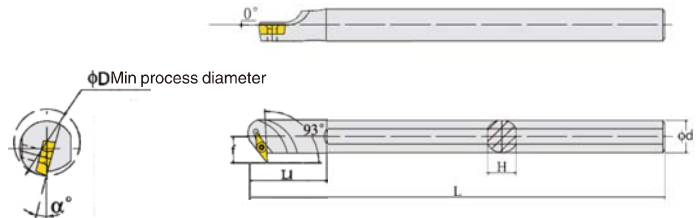

Order ng Code	Stock		Dimensions(mm)							Insert	Screw	Wrench
	R	L	D	d	f	L	L1	H	a°			
S16Q-SVZBR/L11	●	●	22	16	11.5	180	35	15	12	VB**1103	M2.5*6	T-8
S20R-SVZBR/L11	●	●	27	20	14	200	39	18	12			
S20R-SVZBR/L16	●	●	27	20	14	200	50	18	12	VB**1604	M3.5*8	T-15
S25S-SVZBR/L16	●	●	32	25	16.5	250	50	23	8			
S32T-SVZBR/L16	●	●	41	32	22.5	300	55	29	8			
S16Q-SVZCR/L11	●	●	22	16	11.5	180	35	15	8	VC**1103	M2.5*6	T-8
S20R-SVZCR/L11	●	●	27	20	14	200	39	18	6			
S20R-SVZCR/L16	●	●	27	20	14	200	50	18	8	VC**1604	M3.5*8	T-15
S25S-SVZCR/L16	●	●	32	25	16.5	250	50	23	6			
S32T-SVZCR/L16	●	●	41	32	22.5	300	55	29	8			

● Stock ○ Available upon Order

Turning inserts

External turning

Internal turning

Grooving & parting

Threading

Milling

Boring & drilling

Tool holder

Solid carbide end mills

Solid carbide drill & taps

Technical information

S**–SVWB(C)R/L

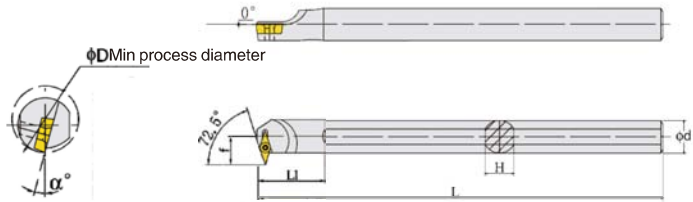

Ordering Code	Stock		Dimensions(mm)							Insert	Screw	Wrench
	R	L	D	d	f	L	L1	H	a°			
S25S–SVWBR/L16	●	●	38	25	23	250	35	23	6	VB**1604	M3.5*8	T-15
S32T–SVWBR/L16	●	●	45	32	26	300	40	29	6			
S25S–SVWCR/L16	●	●	38	25	23	250	35	23	4	VC**1604	M3.5*8	T-15
S32T–SVWCR/L16	●	●	45	32	26	300	40	29	4			

S**–SWLCR/L

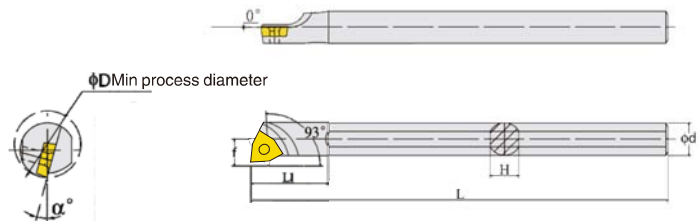

Ordering Code	Stock	Dimensions(mm)							Insert	Screw	Wrench
		D	d	f	L	L1	H	a°			
S08K–SWLCR/L04	●	10.5	8	5.5	125	25	7	13	WC**0402	M2.5*6	T-15
S10K–SWLCR/L04	●	13	10	6.5	125	30	9	10			
S12M–SWLCR/L06	●	16	12	8	150	37	11	13	WC**06T2	M3.5*8	T-15
S16Q–SWLCR/L06	●	20	16	10	180	40	15	10			
S20R–SWLCR/L08	●	25	20	12	200	45	19	8	WC**0804	M5*12	T-20
S25S–SWLCR/L08	●	31	25	14.5	250	45	24	6			

● Stock ○ Available upon Order

Turning inserts

External turning

Internal turning

Grooving & parting

Threading

Milling

Boring & drilling

Tool holder

Solid carbide end mills

Solid carbide drill & taps

Technical information

GROOVING & PARTING TOOLS



Cutting speed recommendations

Material	Carbon steel S50C\Q235		Alloy steel 25-35HRC 4Cr5MoSiVi/Cr12		Stainless steel SUS304/316/ OCr19Ni9		Cast iron HT250/QT450		Aluminium alloy	
	Vc=m/min	f=mm/rev	Vc=m/min	f=mm/rev	Vc=m/min	f=mm/rev	Vc=m/min	f=mm/rev	Vc=m/min	f=mm/rev
External Circular groove	80-150	0.05-0.30	30-100	0.05-0.30	70-120	0.05-0.30	80-150	0.05-0.30	120-300	0.05-0.30
Internal Circular groove	60-120	0.05-0.30	20-80	0.05-0.30	50-100	0.05-0.30	50-100	0.05-0.30	80-250	0.05-0.30
End face groove	80-150	0.05-0.30	30-100	0.05-0.30	70-120	0.05-0.30	60-120	0.05-0.30	80-250	0.05-0.30

■ Toolholder or blade Size

To minimize risk of vibration and deflection always choose:

- Toolholder or blade with the smallest possible overhang
- Toolholder with maximum shank dimension

■ 90° Mounting

It is very important that the insert is mounted at 90° to the center line of the workpiece in order to obtain a perpendicular surface and reduce the risk of vibration.

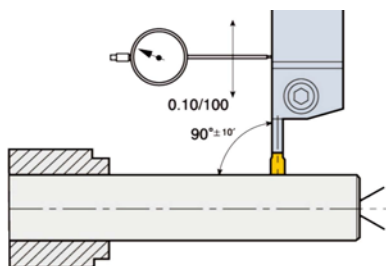

■ Machining Definitions

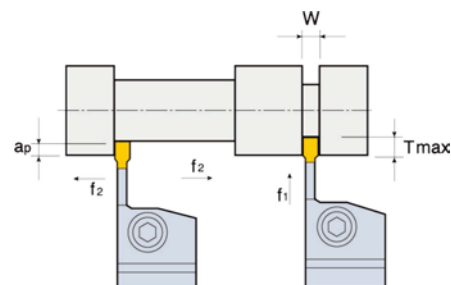

Grooving

- Vc-Cutting Speed(m/min)
- T-Maximum Depth(mm)
- f₁-Feed in Radial Direction(mm/rev)

Turning

- Vc-Cutting Speed(m/min)
- a_{pmax}-Maximum Depth of Cut(mm)
- f₂-Feed in Lateral Direction(mm/rev)

Turning inserts

External turning

Internal turning

Grooving & parting

Threading

Milling

Boring & drilling

Tool holder

Solid carbide end mills

Solid carbide drill & taps

Technical information

MGMN** Case Study

- 1.It has square head and double grooves.
The notch depth is less than 20mm
- 2.Suitable for P/M/K processing
- 3.Suitable for stainless steel , high temperature alloy steel , titanium alloy steel which used in general industry and aerospace industry.

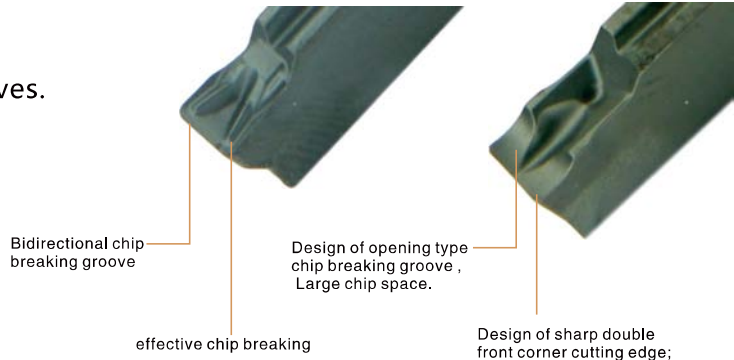

Workpiece material	316(HB200)Stainless steel
Machining parts	Slot cutters
Insert	MGMN300-T-NS4125

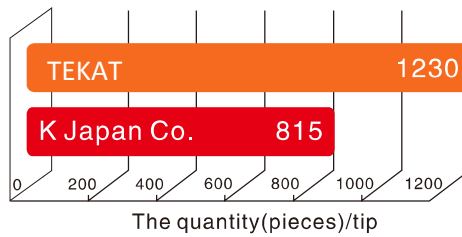

The cutting parameters
 $V_c=106\text{m/min}$
 $f=0.11\text{mm/r}$
 $a_p=3\text{mm}$
 $\phi d=22\text{mm}$



Cutting life
+30%

GBA43** Case Study

- 1.Fine cutting groove
- 2.E level accuracy
- 3.Suitable for P/M/K processing

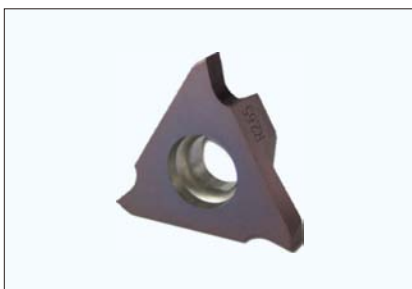
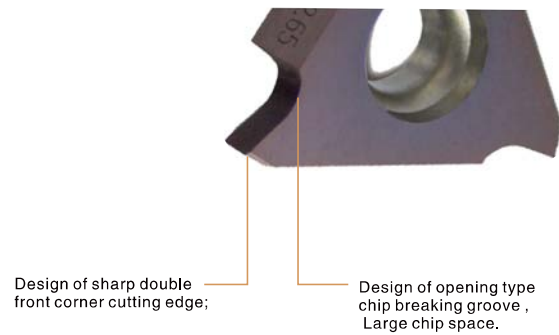



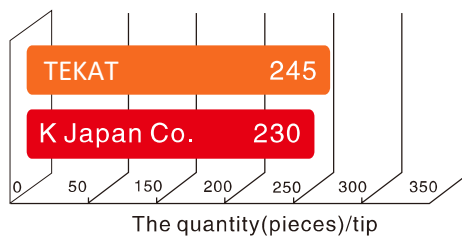



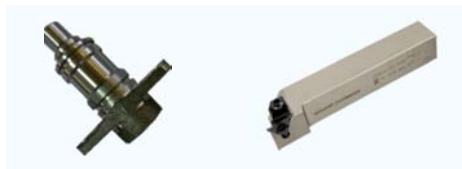













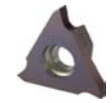
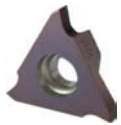

Workpiece material	20CrMnTi(180-220HB)
Machining parts	Slot cutters
Insert	GBA43250-NS4125



The cutting parameters
 $V_c=114\text{m/min}$
 $f=0.10\text{mm/r}$
 $a_p=2.5\text{mm}$
 $\phi d=45\text{mm}$



Cutting life
+5%

<p>GER/L-A</p>  <p>P118</p>	<p>GER/L-AR</p>  <p>P118</p>	<p>GER/L-C</p>  <p>P118</p>	<p>GER/L-D</p>  <p>P118</p>
<p>GER/L-D</p>  <p>P118</p>	<p>GER/L-CR</p>  <p>P119</p>	<p>GER-D</p>  <p>P119</p>	<p>TKF-S</p>  <p>P119</p>
<p>NG2/NG3</p>  <p>P119~P120</p>	<p>NR2/NR3</p>  <p>P120</p>	<p>GBA32R/43R</p>  <p>P120</p>	<p>GBA32</p>  <p>P121</p>
<p>GBA43</p>  <p>P121</p>	<p>T11EN</p>  <p>P121</p>	<p>T16EN</p>  <p>P121~P122</p>	<p>FMM</p>  <p>P122</p>
<p>FGD</p>  <p>P122</p>	<p>MFMN300R</p>  <p>P122</p>	<p>SP-NM</p>  <p>P122</p>	<p>MGGN*L</p>  <p>P122</p>
<p>MGMN*J</p>  <p>P122</p>	<p>MGMN*T</p>  <p>P122</p>	<p>MRMN*M</p>  <p>P123</p>	<p>MRGN*M</p>  <p>P123</p>

Turning inserts

External turning

Internal turning

Grooving & parting

Threading

Milling

Boring & drilling

Tool holder

Solid carbide end mills

Solid carbide drill & taps

Technical information

- Turning inserts
- External turning
- Internal turning
- Grooving & parting
- Threading
- Milling
- Boring & drilling
- Tool holder
- Solid carbide end mills
- Solid carbide drill & taps
- Technical information

ZPE-MG



P123

TDJ



P123

TDC



P123

THC-CE



P123

TKFB*M



P123

SIGER/L



P124

SEGER/L**



P124

GNSR/L



P125

GNAR/L**



P125

KTKFR/L



P126

TKGFL



P126

SGWHR/L



P127

MGWHR/L



P127

SPB



P128

ZQR/L



P128

QE*S



P129

SMBB



P129

MGFHR



P130

MGFHR/L



P130

MGFVR/L



P131

MGNVR/L



P131

FGDHX



P132

MGEHR/L



P133

TTER/L



P134

Grooving & parting tools

The basic shape of inserts	OrderingCode	Stock		Dimensions(mm)							CVD		PVD		Uncoated			
		R	L	W	R	B	d	L	H	A	TP1115	TP1225	TS 7911	TS 7912	TS4115	TS4125	TN9115	
 	GER/L100-005A	●	○	1.00	0.05	1.50	2.50	6.50	2.58	6.69			●	●	●	○		
	GER/L120-005A	○	○	1.20	0.05	1.50	2.50	6.50	2.58	6.69			●	●	●	○		
	GER/L125-005A	●	○	1.25	0.05	1.50	2.50	6.50	2.58	6.69			●	●	●	○		
	GER/L150-010A	●	○	1.50	0.10	1.50	2.50	6.50	2.58	6.69			●	●	●	○		
	GER/L200-010A	●	○	2.00	0.10	1.50	2.50	6.50	2.58	6.69			●	●	●	○		
	GER/L100-005B	●	○	1.00	0.05	2.20	2.70	8.20	3.18	8.46			●	●	●	○		
	GER/L120-005B	○	○	1.20	0.05	2.20	2.70	8.20	3.18	8.46			●	●	●	○		
	GER/L125-005B	●	○	1.25	0.05	2.20	2.70	8.20	3.18	8.46			●	●	●	○		
	GER/L145-010B	○	○	1.45	0.10	2.20	2.70	8.20	3.18	8.46			●	●	●	○		
	GER/L150-010B	●	○	1.50	0.10	2.20	2.70	8.20	3.18	8.46			●	●	●	○		
	GER/L200-010B	●	○	2.00	0.10	2.20	2.70	8.20	3.18	8.46			●	●	●	○		
	GER/L250-020B	●	○	2.50	0.20	2.20	2.70	8.20	3.18	8.46			●	●	●	○		
GER/L300-020B	●	○	3.00	0.20	2.20	2.70	8.20	3.18	8.46			●	●	●	○			
 	GER/L100-050AR	●	○	1.00	0.50	1.50	2.50	6.50	2.58	6.69			●	●	●	○		
	GER/L200-100AR	●	○	2.00	1.00	1.50	2.50	6.50	2.58	6.69			●	●	●	○		
	GER/L100-050BR	●	○	1.00	0.50	2.20	2.70	8.20	3.18	8.46			●	●	●	○		
	GER/L200-100BR	●	○	2.00	1.00	2.20	2.70	8.20	3.18	8.46			●	●	●	○		
 	GER/L100-005C	●	○	1.00	0.05	2.50	2.80	11.48	4.05	5.8			●	●	●	○		
	GER/L120-005C	●	○	1.20	0.05	2.50	2.80	11.48	4.05	5.8			●	●	●	○		
	GER/L125-005C	○	○	1.25	0.05	2.50	2.80	11.48	4.05	5.8			●	●	●	○		
	GER/L145-010C	●	○	1.45	0.10	2.50	2.80	11.48	4.05	5.8			●	●	●	○		
	GER/L150-010C	○	○	1.50	0.10	2.50	2.80	11.48	4.05	5.8			●	●	●	○		
	GER/L170-010C	●	○	1.70	0.10	2.50	2.80	11.48	4.05	5.8			●	●	●	○		
	GER/L185-010C	●	○	2.00	0.10	2.50	2.80	11.48	4.05	5.8			●	●	●	○		
	GER/L200-010C	●	○	2.00	0.10	2.50	2.80	11.48	4.05	5.8			●	●	●	○		
	GER/L250-020C	●	○	2.50	0.20	2.50	2.80	11.48	4.05	5.8			●	●	●	○		
	GER/L300-020C	●	○	3.00	0.20	2.50	2.80	11.48	4.05	5.8			●	●	●	○		
GER/L350-020C	●	○	3.50	0.20	2.50	2.80	11.48	4.05	5.8			●	●	●	○			
 GER100-005E~430-020E GER450-020E~500-020E 	GER/L100-005D	●	○	1.00	0.05	2.50	4.40	16.44	5.05	6.8			●	●	●	○		
	GER/L120-005D	○	○	1.20	0.05	2.50	4.40	16.44	5.05	6.8			●	●	●	○		
	GER/L125-005D	●	○	1.25	0.05	2.50	4.40	16.44	5.05	6.8			●	●	●	○		
	GER/L145-010D	○	○	1.45	0.10	2.50	4.40	16.44	5.05	6.8			●	●	●	○		
	GER/L150-010D	●	○	1.50	0.10	3.00	4.40	16.44	5.05	6.8			●	●	●	○		
	GER/L170-010D	●	○	1.70	0.10	3.00	4.40	16.44	5.05	6.8			●	●	●	○		
	GER/L185-010D	●	○	2.00	0.10	3.00	4.40	16.44	5.05	6.8			●	●	●	○		
	GER/L200-010D	●	○	2.00	0.10	3.20	4.40	16.44	5.05	6.8			●	●	●	○		
	GER/L230-010D	●	○	2.30	0.10	3.20	4.40	16.44	5.05	6.8			●	●	●	○		
	GER/L250-020D	●	○	2.50	0.20	3.20	4.40	16.44	5.05	6.8			●	●	●	○		
	GER/L280-020D	●	○	2.80	0.20	3.20	4.40	16.44	5.05	6.8			●	●	●	○		
	GER/L300-020D	●	○	3.00	0.20	4.50	4.40	16.44	5.05	6.8			●	●	●	○		
	GER/L330-020D	●	○	3.30	0.20	4.50	4.40	16.44	5.05	6.8			●	●	●	○		
	GER/L350-020D	●	○	3.50	0.20	4.50	4.40	16.44	5.05	6.8			●	●	●	○		
GER/L400-020D	●	○	4.00	0.20	4.50	4.40	16.44	5.05	6.8			●	●	●	○			

● Stock ○ Available upon Order

Turning inserts

External turning

Internal turning

Grooving & parting

Threading

Milling

Boring & drilling

Tool holder

Solid carbide end mills

Solid carbide drill & taps

Technical information

- Turning inserts
- External turning
- Internal turning
- Grooving & parting
- Threading
- Milling
- Boring & drilling
- Tool holder
- Solid carbide end mills
- Solid carbide drill & taps
- Technical information

- continuous
- light Interruption
- ⊕ Interruption

P	Steel	●	○
M	Stainless Steel	●	○
K	Cast Iron	●	○
N	Non-ferrous Metal	●	○
S	Heat-resistant Alloy, TiAlloy	●	○









The basic shape of inserts	Ordering Code	Stock		Dimensions(mm)							CVD		PVD			Uncoated		
		R	L	W	R	B	d	L	H	A	TP1115	TP1225	TS 7911	TS 7912	TS4115	TS4125	TN9115	
		●	○															
	GER/L200-100CR	●	○	2.00	1.00	2.50	2.80	11.48	4.05	5.8			●	●	●	○		
	GER/L250-125CR	●	○	2.50	1.25	2.50	2.80	11.48	4.05	5.8			●	●	●	○		
	GER/L300-150CR	●	○	3.00	1.50	2.50	2.80	11.48	4.05	5.8			●	●	●	○		
	GER/L200-100DR	●	○	2.00	1.00	3.20	4.40	16.44	5.05	6.8			●	●	●	○		
	GER/L300-150DR	●	○	3.00	1.50	4.50	4.40	16.44	5.05	6.8			●	●	●	○		
	GER150DM10-D	●	○	1.50	0.1	2.5	3.0		5.05	10			●	●	●	○		
	GER200DM10-D	●	○	2.00	0.1	3	3.0		5.05	10			●	●	●	○		
	GER250DM15-D	●	○	2.50	0.2	3.2	3.0		5.05	15			●	●	●	○		
	GER300DM15-D	●	○	3.00	0.2	4.5	3.0		5.05	15			●	●	●	○		
	GER400DM15-D	●	○	4.00	0.2	4.5	3.0		5.05	15			●	●	●	○		
	TKF12R/L050-S	●	○	0.5	0.03	3	5	0°	8.7	5			●	●	●	○		
	TKF12R/L070-S	●	○	0.7	0.03	3	5	0°	8.7	8			●	●	●	○		
	TKF12R/L100-S	●	○	1	0.03	3	5	0°	8.7	12			●	●	●	○		
	TKF12R/L150-S	●	○	1.5	0.03	3	5	0°	8.7	12			●	●	●	○		
	TKF12R/L200-S	●	○	2	0.03	3	5	0°	8.7	12			●	●	●	○		
	TKF12R/L050-S16R	●	○	0.5	0.05	3	5	16°	8.7	5			●	●	●	○		
	TKF12R/L070-S16R	●	○	0.7	0.05	3	5	16°	8.7	8			●	●	●	○		
	TKF12R/L100-S16R	●	○	1	0.05	3	5	16°	8.7	12			●	●	●	○		
	TKF12R/L150-S16R	●	○	1.5	0.05	3	5	16°	8.7	12			●	●	●	○		
	TKF12R/L200-S16R	●	○	2	0.05	3	5	16°	8.7	12			●	●	●	○		
	TKF16R/L150-S	●	○	1.5	0.05	4	5	0°	9.5	16			●	●	●	○		
	TKF16R/L200-S	●	○	2	0.05	4	5	0°	9.5	16			●	●	●	○		
	TKF16R/L250-S	●	○	2.5	0.05	4	5	0°	9.5	16			●	●	●	○		
	TKF16R/L300-S	●	○	3	0.05	4	5	0°	9.5	16			●	●	●	○		
	TKF16R/L150-S16R	●	○	1.5	0.05	4	5	16°	9.5	16			●	●	●	○		
	TKF16R/L200-S16R	●	○	2	0.05	4	5	16°	9.5	16			●	●	●	○		
	TKF16R/L250-S16R	●	○	2.5	0.05	4	5	16°	9.5	16			●	●	●	○		
	TKF16R/L300-S16R	●	○	3	0.05	4	5	16°	9.5	16			●	●	●	○		
		NG2031R/L	○	○	0.79	0.09	1.27	5.56	8.74	3.81					●	●	○	
		NG2M100R/L	●	●	1.00	0.09	1.27	5.56	8.74	3.81					●	●	●	
NG2047LR/L		●	●	1.19	0.09	1.27	5.56	8.74	3.81					●	●	○		
NG2M120R/L		○	○	1.20	0.09	1.27	5.56	8.74	3.81					●	●	○		
NG2M150R/L		●	●	1.50	0.19	2.79	5.56	8.74	3.81					●	●	●		
NG2062R/L		●	●	1.58	0.19	2.79	5.56	8.74	3.81					●	●	○		
NG2M170R/L		○	○	1.70	0.19	2.79	5.56	8.74	3.81					●	●	●		
NG2078R/L		●	●	1.98	0.19	2.79	5.56	8.74	3.81					●	●	○		
NG2M200R/L		○	○	2.00	0.19	2.79	5.56	8.74	3.81					●	●	●		
NG2M220R/L		●	●	2.20	0.19	2.79	5.56	8.74	3.81					●	●	○		
NG2M250R/L		○	○	2.50	0.19	2.79	5.56	8.74	3.81					●	●	●		
NG2M275R/L		○	○	2.75	0.19	2.79	5.56	8.74	3.81					●	●	○		
NG2M300R/L		○	○	3.00	0.19	2.79	5.56	8.74	3.81					●	●	○		
NG2125R/L		●	●	3.18	0.19	2.79	5.56	8.74	3.81					●	●	○		
NG2M325R/L		○	○	3.25	0.19	2.79	5.56	8.74	3.81					●	●	○		

● Stock ○ Available upon Order

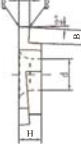
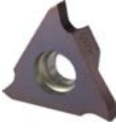
- Turning inserts
- External turning
- Internal turning
- Grooving & parting
- Threading
- Milling
- Boring & drilling
- Tool holder
- Solid carbide end mills
- Solid carbide drill & taps
- Technical information

- continuous
- light Interruption
- Interruption

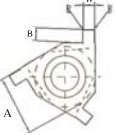
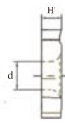
P	Steel	
M	Stainless Steel	
K	Cast Iron	
N	Non-ferrous Metal	
S	Heat-resistant Alloy, TiAlloy	

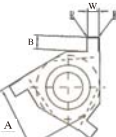
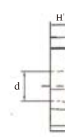
The basic shape of inserts	OrderingCode	Stock		Dimensions(mm)							CVD		PVD			Uncoated	
		R	L	W	R	B	d	L	H	A	TP1115	TP1225	TS 7911	TS 7912	TS4115	TS4125	TN9115
  	GBA32120R/L	○	○	1.20	0.10	2.30	4.50		3.18	9.52			●	●	○	○	○
	GBA32125R/L	●	●	1.25	0.10	2.30	4.50		3.18	9.52			●	●	●	○	○
	GBA32130R/L	○	○	1.30	0.10	2.30	4.50		3.18	9.52			●	●	○	○	○
	GBA32140R/L	○	○	1.40	0.10	2.30	4.50		3.18	9.52			●	●	○	○	○
	GBA32145R/L	○	○	1.45	0.10	2.30	4.50		3.18	9.52			●	●	○	○	○
	GBA32150R/L	●	●	1.50	0.10	2.30	4.50		3.18	9.52			●	●	●	○	○
	GBA32160R/L	○	○	1.60	0.10	2.30	4.50		3.18	9.52			●	●	○	○	○
	GBA32175R/L	●	○	1.75	0.10	2.30	4.50		3.18	9.52			●	●	●	○	○
	GBA32180R/L	○	○	1.80	0.10	2.30	4.50		3.18	9.52			●	●	○	○	○
	GBA32200R/L	●	●	2.00	0.10	2.80	4.50		3.18	9.52			●	●	●	○	○
	GBA32225R/L	○	○	2.25	0.10	2.80	4.50		3.18	9.52			●	●	○	○	○
	GBA32250R/L	●	●	2.50	0.10	2.80	4.50		3.18	9.52			●	●	●	○	○
	GBA32275R/L	○	○	2.75	0.10	2.80	4.50		3.18	9.52			●	●	○	○	○
	GBA32300R/L	●	○	3.00	0.20	2.80	4.50		3.18	9.52			●	●	●	○	○
  	GBA43125R/L	●	○	1.25	0.20	2.00	5.40		4.76	12.70			●	●	●	○	○
	GBA43140R/L	○	○	1.40	0.20	2.00	5.40		4.76	12.70			●	●	○	○	○
	GBA43145R/L	○	○	1.45	0.20	3.50	5.40		4.76	12.70			●	●	○	○	○
	GBA43150R/L	●	○	1.50	0.20	3.50	5.40		4.76	12.70			●	●	●	○	○
	GBA43170R/L	○	○	1.70	0.20	3.50	5.40		4.76	12.70			●	●	○	○	○
	GBA43175R/L	●	○	1.75	0.20	3.50	5.40		4.76	12.70			●	●	●	○	○
	GBA43185R/L	○	○	1.85	0.20	3.50	5.40		4.76	12.70			●	●	○	○	○
	GBA43195R/L	○	○	1.95	0.20	3.50	5.40		4.76	12.70			●	●	○	○	○
	GBA43200R/L	●	○	2.00	0.20	3.50	5.40		4.76	12.70			●	●	●	○	○
	GBA43225R/L	○	○	2.25	0.20	3.50	5.40		4.76	12.70			●	●	○	○	○
	GBA43230R/L	○	○	2.30	0.20	3.50	5.40		4.76	12.70			●	●	○	○	○
	GBA43250R/L	●	○	2.50	0.30	4.00	5.40		4.76	12.70			●	●	●	○	○
	GBA43265R/L	○	○	2.65	0.30	4.00	5.40		4.76	12.70			●	●	○	○	○
	GBA43280R/L	○	○	2.80	0.30	4.00	5.40		4.76	12.70			●	●	○	○	○
GBA43300R/L	●	○	3.00	0.30	4.00	5.40		4.76	12.70			●	●	●	○	○	
GBA43350R/L	○	○	3.50	0.30	5	5.40		4.76	12.70			●	●	○	○	○	
GBA43400R/L	○	○	4.00	0.40	5	5.40		4.76	12.70			●	●	○	○	○	
  	T11EN050R/L	○	○	0.50	0.06	1.00	3.00		3.10	6.35			●	●	○	○	○
	T11EN060R/L	○	○	0.60	0.06	1.00	3.00		3.10	6.35			●	●	○	○	○
	T11EN080R/L	○	●	0.80	0.06	1.20	3.00		3.10	6.35			●	●	●	○	○
	T11EN100R/L	○	●	1.00	0.10	1.50	3.00		3.10	6.35			●	●	●	○	○
	T11EN120R/L	○	○	1.20	0.10	1.50	3.00		3.10	6.35			●	●	○	○	○
	T11ENR140/L	○	○	1.40	0.10	1.50	3.00		3.10	6.35			●	●	○	○	○
  	T11ENR150/L	○	●	1.50	0.10	1.50	3.00		3.10	6.35			●	●	●	○	○
	T16EN050R/L	○	○	0.50	0.06	1.50	4.00		3.50	9.52			●	●	○	○	○
	T16EN060R/L	○	●	0.60	0.06	1.50	4.00		3.50	9.52			●	●	○	○	○
	T16EN080R/L	○	●	0.80	0.06	1.50	4.00		3.50	9.52			●	●	●	○	○
	T16EN090R/L	○	○	0.90	0.06	1.50	4.00		3.50	9.52			●	●	○	○	○
T16EN100R/L	○	●	1.00	0.06	1.50	4.00		3.50	9.52			●	●	●	○	○	

● Stock ○ Available upon Order

Grooving & parting tools

The basic shape of inserts	Ordering Code	Stock		Dimensions(mm)							CVD		PVD		Uncoated		
		R	L	W	R	B	d	L	H	A	TP1115	TP1225	TS 7911	TS 7912	TS4115	TS4125	TN9115
	T16EN110R/L	○	○	1.10	0.06	1.50	4.00	3.50	9.52			●	●	○	○		
	T16EN120R/L	○	●	1.20	0.06	1.50	4.00	3.50	9.52			●	●	●	○		
	T16EN125R/L	○	●	1.25	0.06	1.50	4.00	3.50	9.52			●	●	●	○		
	T16EN130R/L	○	○	1.3	0.10	1.50	4.00	3.50	9.52			●	●	○	○		
	T16EN140R/L	○	○	1.4	0.10	1.8	4.00	3.50	9.52			●	●	○	○		
	T16EN150R/L	○	●	1.5	0.10	1.8	4.00	3.50	9.52			●	●	●	○		
	T16EN160R/L	○	○	1.6	0.10	1.8	4.00	3.50	9.52			●	●	○	○		
	T16EN170R/L	○	○	1.7	0.10	1.8	4.00	3.50	9.52			●	●	○	○		
	T16EN175R/L	○	●	1.75	0.10	1.8	4.00	3.50	9.52			●	●	●	○		
	T16EN180R/L	○	●	1.80	0.10	1.8	4.00	3.50	9.52			●	●	●	○		
	T16EN200R/L	○	●	2.00	0.10	1.8	4.00	3.50	9.52			●	●	●	○		
	T16EN215R/L	○	○	2.15	0.10	2.00	4.00	3.50	9.52			●	●	○	○		
	T16EN225R/L	○	○	2.25	0.20	2.00	4.00	3.50	9.52			●	●	○	○		
	T16EN230R/L	○	●	2.30	0.20	2.00	4.00	3.50	9.52			●	●	●	○		
	T16EN250R/L	○	●	2.50	0.20	2.00	4.00	3.50	9.52			●	●	●	○		
		FMM300R-03	●		3.00	0.30	2.00	15.00	3.91		○		●	●	●		
FMM400R-03		●		4.00	0.40	3.00	15.00	3.96		○		●	●	●			
FMM500R-04		●		5.00	0.40	4.00	15.00	4.42		○		●	●	●			
	FGD300R-03	●		3.00	0.30	2.00	15.00	4.00		○		●	●	●			
	FGD400R-03	●		4.00	0.40	3.00	15.00	4.50		○		●	●	●			
	FGD500R-04	●		5.00	0.40	4.00	15.00	5.00		○		●	●	●			
	MFMN300R	●	○	3.00	0.30	2.1	19.00	5.40		●		●	●	●			
	SP200-NM	●		2.2	0.2		9.3			●		●	●	●			
	SP300-NM	●		3.1	0.2		11.3			●		●	●	●			
	SP400-NM	●		4.1	0.25		11.3			●		●	●	●			
	SP500-NM	●		5.1	0.3		11.4			●		●	●	●			
	MGGN200L	●		2	0.2	1.5	16	3.5		●		●	●	●		●	
	MGGN300L	●		3	0.4	2.35	21	4.8		●		●	●	●		●	
	MGGN400L	●		4	0.4	3.3	21	4.8		●		●	●	●		●	
	MGGN500L	●		5	0.8	4.12	25.9	5.8		●		●	●	●		●	
	MGMN200J	●		2	0.2	1.6	16	3.5		○		●	●	●		●	
	MGMN300J	●		3	0.4	2.35	21	4.8		○		●	●	●		●	
	MGMN400J	●		4	0.4	3.3	21	4.8		○		●	●	●		●	
	MGMN500J	●		5	0.8	4.12	26	5.8		○		●	●	●		●	
	MGMN200T	●		2	0.2	1.6	16	3.5		○		●	●	●		●	
	MGMN300T	●		3	0.4	2.35	21	4.8		○		●	●	●		●	
	MGMN400T	●		4	0.4	3.3	21	4.8		○		●	●	●		●	
	MGMN500T	●		5	0.8	4.12	26	5.8		○		●	●	●		●	

● Stock ○ Available upon Order

Turning inserts

External turning

Internal turning

Grooving & parting

Threading

Milling

Boring & drilling

Tool holder

Solid carbide end mills

Solid carbide drill & taps

Technical information

- Turning inserts
- External turning
- Internal turning
- Grooving & parting
- Threading
- Milling
- Boring & drilling
- Tool holder
- Solid carbide end mills
- Solid carbide drill & taps
- Technical information

- continuous
- light Interruption
- Interruption

P	Steel		
M	Stainless Steel		
K	Cast Iron		
N	Non-ferrous Metal		
S	Heat-resistant Alloy, TiAlloy		

The basic shape of inserts	Ordering Code	Stock	Dimensions(mm)							CVD		PVD		Uncoated		
			W	R	B	d	L	H	A	TP1115	TP1225	TS 7911	TS 7912	TS4115	TS4125	TN9115
	MRMN200M	●	2	1	1.6		16	3.5		●		●	●			
	MRMN300M	●	3	1.5	2.35		21	4.8		●		●	●			
	MRMN400M	●	4	2	3.3		21	4.8		●		●	●			
	MRMN500M	●	5	2.5	4.12		26	5.8		●		●	●			
	MRGN400M	●	2	1	1.6		16	3.5				●	●			●
	MRGN500M	●	3	1.5	2.35		21	4.8				●	●			●
	MRGN600M	●	4	2	3.3		21	4.8				●	●			●
	MRGN800M	●	5	2.5	4.12		26	5.8				●	●			●
	ZPES02502-MG	●	2.5	0.2			20	3.9		○		●	●			●
	ZPFS0302-MG	●	3	0.2			20	4		○		●	●			●
	ZPGS0402-MG	●	4	0.2			20	4		○		●	●			●
	ZPHS0503-MG	●	5	0.3			25	4.9		○		●	●			●
	TDJ2	●	2	0.2	1.7		20	3.9		○		●	●			●
	TDJ3	●	3	0.2	2.4		20	4		○		●	●			●
	TDJ4	●	4	0.3	3		20	4		○		●	●			●
	TDJ5	●	5	0.3	4		25	4.9		○		●	●			●
	TDC2	●	2	0.2	1.7		20	3.9		○		●	●			●
	TDC3	●	3	0.2	2.4		20	4		○		●	●			●
	TDC4	●	4	0.3	3		20	4		○		●	●			●
	TDC5	●	5	0.3	4		25	4.9		○		●	●			●
	THC42R100-CE	●	1	0.06	3.04		5	7.94	0°			●	●		○	○
	THC42R100-CE15R	●	1	0.06	3.04		5	7.94	15°			●	●		○	○
	THC42R150-CE	●	1.5	0.06	3.04		8.5	7.94	0°			●	●		○	○
	THC42R150-CE15R	●	1.5	0.06	3.04		8.5	7.94	15°			●	●		○	○
	THC42R200-CE	●	2	0.1	3.04		11.5	7.94	0°			●	●		○	○
	THC42R200-CE15R	●	2	0.1	3.04		11.5	7.94	15°			●	●		○	○
	THC42R250-CE	●	2.5	0.1	3.04		11.5	7.94	0°			●	●		○	○
	THC42R250-CE15R	●	2.5	0.1	3.04		11.5	7.94	15°			●	●		○	○
	THC42R300-CE	●	3	0.2	3.04		11.5	7.94	0°			●	●		○	○
	THC42R300-CE15R	●	3	0.2	3.04		11.5	7.94	15°			●	●		○	○
	THC42R200-CN	●	2	0.1	3.04		11.5	7.94	0°			●	●		○	○
	THC42R200-CU15R	●	2	0.1	3.04		11.5	7.94	15°			●	●		○	○
	THC42R250-CN	●	2.5	0.1	3.04		11.5	7.94	0°			●	●		○	○
	THC42R250-CU15R	●	2.5	0.1	3.04		11.5	7.94	15°			●	●		○	○
	THC42R300-CN	●	3	0.2	3.04		11.5	7.94	0°			●	●		○	○
	THC42R300-CU15R	●	3	0.2	3.04		11.5	7.94	15°			●	●		○	○
	TKFB12R15005M	●	1.5	0.05	3	5.0	2.6	8.7	0.25			●	●		○	○
	TKFB12R28005M	●	2.8	0.05	3	5.0	4.6	8.7	0.3			●	●		○	○
	TKFB12R28010M	●	2.8	0.1	3	5.0	4.6	8.7	0.3			●	●		○	○
	TKFB16R38005M	●	3.8	0.05	4	5.0	6.3	9.5	0.3			●	●		○	○
	TKFB16R38010M	●	3.8	0.1	4	5.0	6.3	9.5	0.3			●	●		○	○

● Stock ○ Available upon Order

SIGER/L

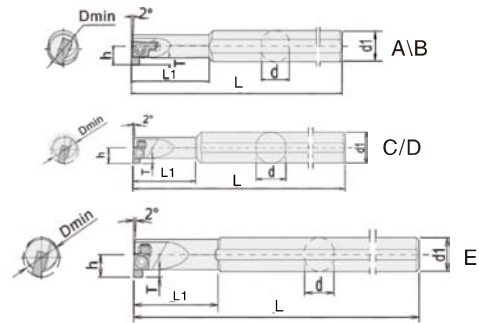

Ordering Code	Stock		Dimensions(mm)							Insert	Screw	Wrench
	R	L	Dimin	d	d1	T	h	L	L1			
SIGER/L0808A	●	○	8	7.2	8	1.5	4.8	100	20	GER/L***A	M2.2*5	T-7
SIGER/L1010B	●	○	10	9	10	2.2	6.2	125	25			
SIGER/L1210B	●	○	12	9	12	2.2	7	125	30	GER/L***B	M2.5*6	T-8
SIGER/L1412C	●	○	14	11.4	14	2.5	8	150	33			
SIGER/L1612C	●	○	16	11.4	16	2.5	8.5	150	20	GER/L***B	M2.5*6	T-8
SIGER/L1616C	●	○	16	15	16	2.5	9	160	36			
SIGER/L2020D	●	○	20	19	20	4.5	12.1	180	40	GER/L***D	M3*8	T-10

SEGER/L**

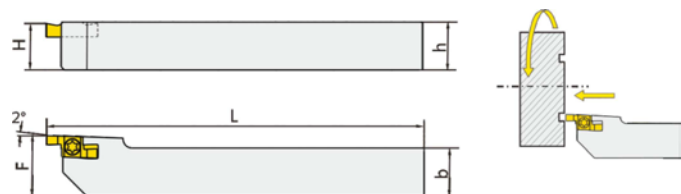

Ordering Code	Stock		Dimensions(mm)						Insert	Screw	Wrench
	R	L	Dimin	H	b	F	L	h			
SEGER/L1010K-D	○	●	10	10	10	10	125	10	GER/L***DM	M3*8	T-10
SEGER/L1212K-D	○	●	10	12	12	12	125	12			
SEGER/L1616H-D	○	●	10	16	16	20	100	16			
SEGER/L2020K-D	○	●	10	20	20	25	125	20			
SEGER/L2525M-D	○	●	10	25	25	32	150	25			

● Stock ○ Available upon Order

Turning inserts

External turning

Internal turning

Grooving & parting

Threading

Milling

Boring & drilling

Tool holder

Solid carbide end mills

Solid carbide drill & taps

Technical information

GNSR/L

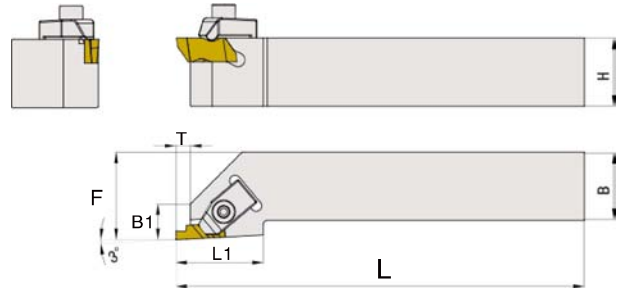
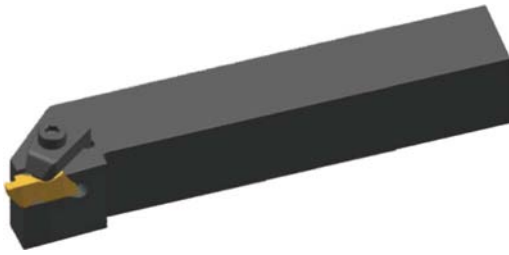

Ordering Code	Stock		Dimensions(mm)							Insert	Clamp	Screw	Wrench
	R	L	H	B	F	L	L1	B1	T				
GNSR/L1616H2	●	○	16	16	20	100	19	9	3.5	NG2***	YBNG2	NG2520	L4.0
GNSR/L2020K2	●	○	20	20	25	125	19	9	3.5				
GNSR/L2525M2	●	○	25	25	32	150	19	9	3.5				
GNSR/L2020K3	●	○	20	20	25	125	32	13	5.3	NG3***	YBNG3	NG3620	L5.0
GNSR/L2525K3	●	○	25	25	32	150	32	13	5.3				

GNAR/L**

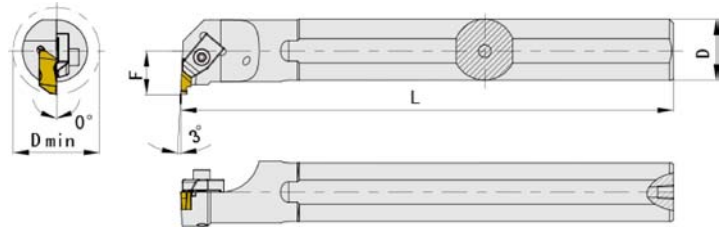

Ordering Code	Stock		Dimensions(mm)				Insert	Clamp	Screw	Wrench
	R	L	Dimin	D	F	L				
GNAR/L20Q2	●	○	26	20	13	180	NG2***	YBNG2	NG2520	L4.0
GNAR/L25R2	●	○	34	25	17	200				
GNAR/L25R3	●	○	34	25	17	200	NG3***	YBNG3	NG3620	L5.0

● Stock ○ Available upon Order

Turning inserts

External turning

Internal turning

Grooving & parting

Threading

Milling

Boring & drilling

Tool holder

Solid carbide end mills

Solid carbide drill & taps

Technical information

KTKFR/L

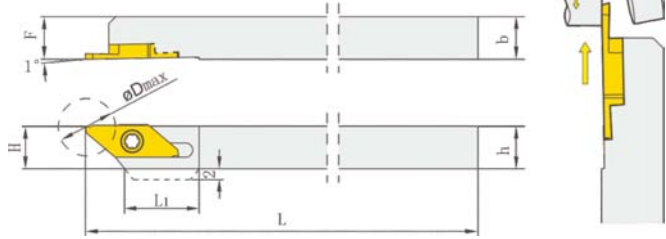

Ordering Code	Stock		Dimensions(mm)							Insert	Screw	Wrench
	R	L	D	h	b	L	L1	f	H			
KTKFR/L1010K12	●	○	12	10	10	125	15	10	10	TKFT12***	SPM4*10	T-15
KTKFR/L1212M12	●	○	12	12	12	150	15	12	12			
KTKFR/L1616M12	●	○	12	16	16	150	15	16	16			
KTKFR/L1010K16	●	○	16	10	10	125	20	10	10	TKFT16***		
KTKFR/L1212M16	●	○	16	12	12	150	20	12	12			
KTKFR/L1616M16	●	○	16	16	16	150	20	16	16			

THCR

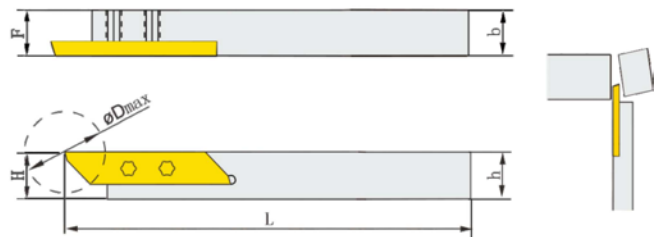

Ordering Code	Stock		Dimensions(mm)						Insert	Screw	Wrench
	R	L	h	b	H	F	L	D			
THCR/L1010J42	○	○	10	10	10	12	85	21	THC42R/L	M4X8	T-15
THCR/L1212J42	○	○	12	12	12	16	100				
THCR/L1616J42	○	○	16	16	16	20	100				
THCR/L2020K42	○	○	20	20	20	25	125				
THCR/L2525M42	○	○	25	25	25	32	150				

● Stock ○ Available upon Order

Turning inserts

External turning

Internal turning

Grooving & parting

Threading

Milling

Boring & drilling

Tool holder

Solid carbide end mills

Solid carbide drill & taps

Technical information

SGWHR/L

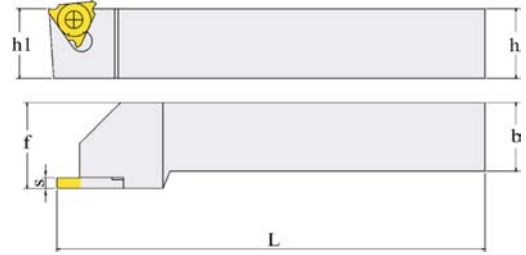

Ordering Code	Stock		Dimensions(mm)						Insert	Screw	Screw
	R	L	h	b	L	f	S	h1			
SGWHR/L1212H3200	●	●	12	12	100	16	0.5-1.8	12	GBA32***	M3.5*8	T-15
SGWHR/L1212H3215	●	●	12	12	100	16	1.8-2.3	12			
SGWHR/L1616H3200	●	●	16	16	100	20	0.5-1.8	16			
SGWHR/L1616H3215	●	●	16	16	100	20	1.8-2.3	16			
SGWHR/L2020K3200	●	●	20	20	125	25	0.5-1.8	20			
SGWHR/L2020K3215	●	●	20	20	125	25	1.8-2.3	20			
SGWHR/L2020K3223	●	●	20	20	125	25	2.3-3.3	20			
SGWHR/L2525M3200	●	●	25	25	150	32	0.5-1.8	25			
SGWHR/L2525M3215	●	●	25	25	150	32	1.8-2.3	25			
SGWHR/L2525M3223	●	●	25	25	150	32	2.3-3.3	25			

MGWHR/L

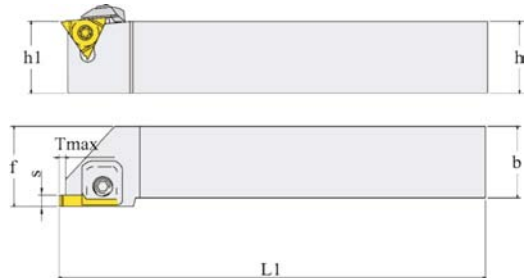

Ordering Code	Stock		Dimensions(mm)						Insert	Screw	Screw	Spring	Wrench
	R	L	h	b	L	f	S	h1					
MGWHR/L1616H4315A	●	●	16	16	100	20	1.25-1.5	16	GBA43***	NLJ0522	YB1318	DTH0814	L4.0
MGWHR/L1616H4315	●	●	16	16	100	20	1.5-2.3	16					
MGWHR/L1616H4325	●	●	16	16	100	20	2.3-3.3	16					
MGWHR/L2020K4315A	●	●	20	20	125	25	1.25-1.5	20					
MGWHR/L2020K4315	●	●	20	20	125	25	1.5-2.3	20					
MGWHR/L2020K4323	●	●	20	20	125	25	2.3-3.3	20					
MGWHR/L2525K4315A	●	●	25	25	150	32	1.25-1.5	25					
MGWHR/L2525K4315	●	●	25	25	150	32	1.5-2.3	25					
MGWHR/L2525K4323	●	●	25	25	150	32	2.3-3.3	25					
MGWHR/L2525K4333	●	●	25	25	150	32	3.3-4.7	25					

● Stock ○ Available upon Order

Turning inserts

External turning

Internal turning

Grooving & parting

Threading

Milling

Boring & drilling

Tool holder

Solid carbide end mills

Solid carbide drill & taps

Technical information

SPB

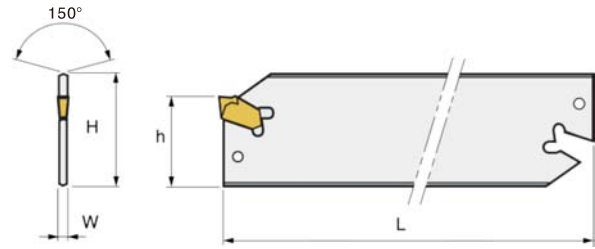

Ordering Code	Stock		Dimensions(mm)					Insert	Screw
	R	W	h	H	L				
SPB226-S	●	1.6	21	26	110	SP200	SW80-S		
SPB326-S	●	2.4	21	26	110	SP300			
SPB426-S	●	3.2	21	26	110	SP400			
SPB526-S	●	4	21	26	110	SP500			
SPB232-S	●	1.6	25	32	150	SP200			
SPB332-S	●	2.4	25	32	150	SP300			
SPB432-S	●	3.2	25	32	150	SP400			
SPB532-S	●	4	25	32	150	SP500			

ZQR/L

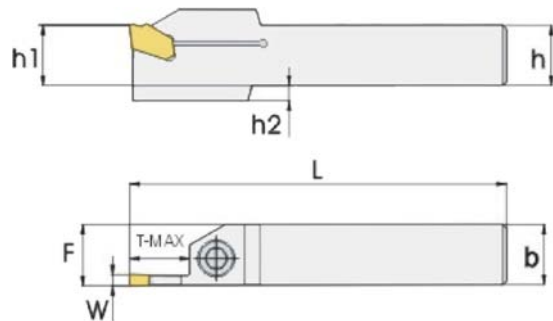

Ordering Code	Stock		Dimensions(mm)						Insert	Screw	Wrench
	R	L	W	h	H	b	F	L			
ZQR/L1616H-02	●	●	1.6	16	16	16	16.3	100	SP200	NLJ0416	L3.0
ZQR/L2020K-02	●	●	1.6	20	20	20	20.3	125			
ZQR/L1616H-03	●	●	2.4	16	16	16	16.3	100	SP300	NLJ0520	L4.0
ZQR/L2020K-03	●	●	2.4	20	20	20	20.3	125			
ZQR/L2525M-03	●	●	2.4	25	25	25	25.3	150			
ZQR/L3232P-03	●	●	2.4	32	32	32	32.3	170	SP400		
ZQR/L1616H-04	●	●	3.2	16	16	16	16.3	100			
ZQR/L2020K-04	●	●	3.2	20	20	20	20.3	125			
ZQR/L2525M-04	●	●	3.2	25	25	25	25.3	150			
ZQR/L3232P-04	●	●	3.2	32	32	32	32.3	170			

● Stock ○ Available upon Order

Turning inserts

External turning

Internal turning

Grooving & parting

Threading

Milling

Boring & drilling

Tool holder

Solid carbide end mills

Solid carbide drill & taps

Technical information

QE*S

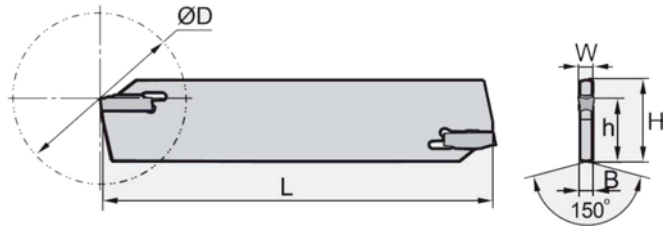

Ordering Code	Stock		Dimensions(mm)						Insert	Wrench
	R	L	L	H	h	B	W	φ D		
QEES226N	●	●	110	26	19	2	2.5	60	ZPES02502-MG	L5.0
QEFS326N	●	●	110	26	19	2.4	3	60	ZPES0302-MG	
QEGS426N	●	●	110	26	19	3.2	4	70	ZPGS0402-MG	
QEHS526N	●	●	110	26	19	4	5	70	ZPHS0503-MG	
QEKs626N	●	●	110	26	19	5	6	70	ZPKS0604-MG	
QEES232N	●	●	150	32	24.6	2	2.5	100	ZPES0202-MG	
QEFS332N	●	●	150	32	24.6	2.4	3	100	ZPFS0302-MG	
QEGS432N	●	●	150	32	24.6	3.2	4	120	ZPGS0402-MG	
QEHS532N	●	●	150	32	24.6	4	5	120	ZPHS0503-MG	
QEKs632N	●	●	150	32	24.6	5	6	120	ZPKS0604-MG	

SMBB

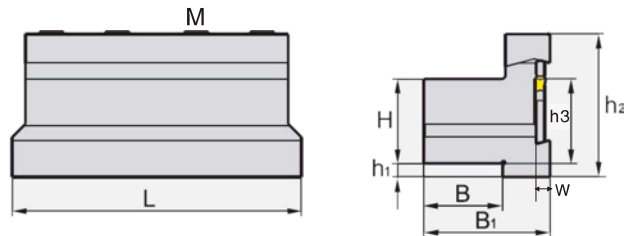

Ordering Code	Stock		Dimensions(mm)									Insert	Wrench
	R	L	H	B	h3	L	h2	h1	B1	W	M		
SMBB1626	●	●	16	12	26	86	43	13	30	5.3	3-M6	SPB□□□(S) QEES**N	L5.0
SMBB2026	●	●	20	19	26	86	43	9	38	5.3	3-M6		
SMBB2032	●	●	20	19	32	100	50	13	38	5.3	4-M6		
SMBB2526	●	●	25	23	26	86	43	4	42	5.3	3-M6		
SMBB2532	●	●	25	23	32	110	50	8	42	5.3	4-M6		
SMBB3232	●	●	32	30	32	110	54	5	48	5.3	4-M6		

● Stock ○ Available upon Order

- Turning inserts
- External turning
- Internal turning
- Grooving & parting
- Threading
- Milling
- Boring & drilling
- Tool holder
- Solid carbide end mills
- Solid carbide drill & taps
- Technical information

MGFHRR

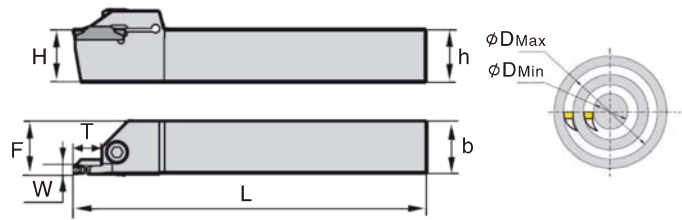

Ordering Code	Stock	Dimensions(mm)								Insert	Screw	Wrench
	R	h	b	L	S	D	H	T	W			
MGFHRR 325-24/35-T10	●	25	25	150	25.6	24-35	25	10	3.0			
MGFHRR 325-29/40-T10	●					29-40						
MGFHRR 325-34/50-T10	●					34-50						
MGFHRR 325-44/70-T10	●					44-70						
MGFHRR 325-64/99-T10	●					64-99						
MGFHRR 425-62/120-T15	●					62-120						
MGFHRR 425-112/200-T15	●					112-200	15	4.0				

MGFHR/L

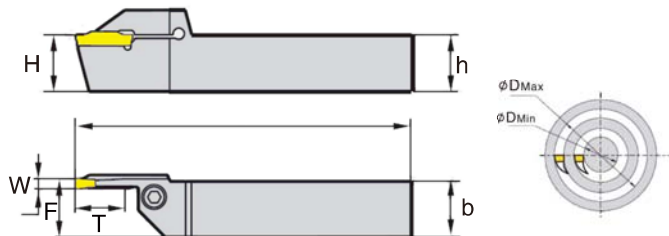

Ordering Code	Stock		Dimensions(mm)								Insert	Screw	Wrench
	R	L	h	b	L	F	D	H	T	W			
MGFHR/L 325-24/35-T10	●	○	25	25	150	25.6	24-35	25	10	3.0			
MGFHR/L 325-29/40-T10	●	○					29-40						
MGFHR/L 325-34/50-T10	●	○					34-50						
MGFHR/L 325-44/70-T10	●	○					44-70						
MGFHR/L 325-64/99-T10	●	○					64-99						
MGFHR/L 320-44/62-T15	●	○					44-62						
MGFHR/L 320-62/120-T15	●	○	20	20	125	20.6	62-120	20	3.0				
MGFHR/L 320-112/200-T15	●	○					112-200						
MGFHR/L 325-44/62-T15	●	○	25	25	150	25.6	44-62	25	15	4.0			
MGFHR/L 325-62/120-T15	●	○					62-120						
MGFHR/L 325-112/200-T15	●	○	20	20	125	20.6	112-200	20	4.0				
MGFHR/L 420-44/62-T15	●	○					44-62						
MGFHR/L 420-62/120-T15	●	○	20	20	125	20.6	62-120	20	4.0				
MGFHR/L 420-112/200-T15	●	○					112-200						
MGFHR/L 425-44/62-T15	●	○	25	25	150	25.6	44-62	25	4.0				
MGFHR/L 425-62/120-T15	●	○					62-120						
MGFHR/L 425-112/200-T15	●	○					112-200						

● Stock ○ Available upon Order

Turning inserts

External turning

Internal turning

Grooving & parting

Threading

Milling

Boring & drilling

Tool holder

Solid carbide end mills

Solid carbide drill & taps

Technical information

MGFVR/L

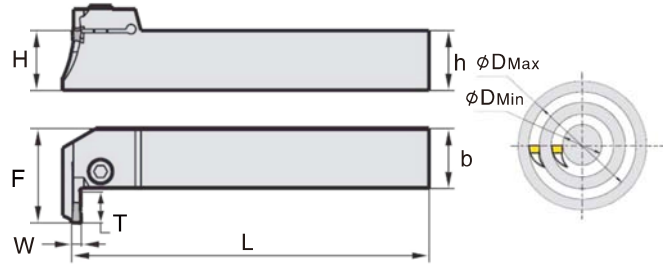
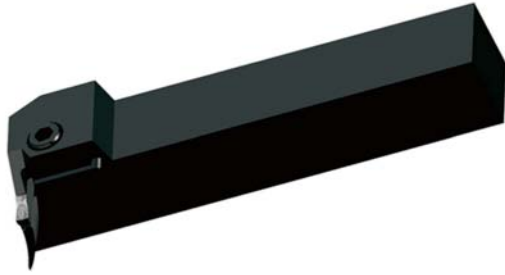

Ordering Code	Stock		Dimensions(mm)								Insert	Screw	Wrench
	R	L	h	b	L	F	D	H	T	W			
MGFVR/L 320-44/62-T15	●	○	20	20	125	20.6	44-64	20	15	3.0	MG*N300	NLJ0620	L5.0
MGFVR/L 320-62/120-T15	●	○					62-120						
MGFVR/L 320-112/200-T15	●	○					112-200						
MGFVR/L 325-44/62-T15	●	○	25	25	150	25.6	62-120	25	4.0	MG*N400			
MGFVR/L 325-62/120-T15	●	○					112-200						
MGFVR/L 325-112/200-T15	●	○					112-200						
MGFVR/L 420-44/62-T15	●	○	20	20	125	20.6	62-120	20	15	MG*N400			
MGFVR/L 420-62/120-T15	●	○					112-200						
MGFVR/L 420-112/200-T15	●	○					112-200						
MGFVR/L 425-44/62-T15	●	○	25	25	150	25.6	62-120	25	15	MG*N400			
MGFVR/L 425-62/120-T15	●	○					112-200						
MGFVR/L 425-112/200-T15	●	○					112-200						

MGNVR/L

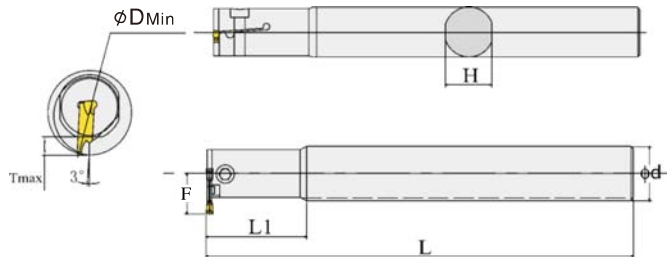

Ordering Code	Stock		Dimensions(mm)							Insert	Screw	Wrench	
	R	L	D	d	L	L1	T	H	F				
MGNVR/L 2016K-2	●	●	20	16	125	35	5	15	12.4	MG*N200	M5*15	T-20	
MGNVR/L 2520M-2	●	●	25	20	150	45		18	14				
MGNVR/L 2925R-2	●	●	29	25	200	45		23	17.2				
MGNVR/L 2520M-2.5	●	●	25	20	150	45	6	18	15.1		MG*N250	NLJ0516	L4.0
MGNVR/L 2925R-2.5	●	●	29	25	200	45		23	18.2				
MGNVR/L 2520M-3	●	●	25	20	150	45		18	15.6				
MGNVR/L 3125R-3	●	●	31	25	200	45	8	23	18.9	MG*N300	NLJ0516	L4.0	
MGNVR/L 3732S-3	●	●	37	32	250	65		29	21.5				
MGNVR/L 2520M-4	●	●	25	20	150	45		18	15.6				
MGNVR/L 3125R-4	●	●	31	25	200	45	8	23	18.9	MG*N400	M5*15	T-20	
MGNVR/L 3732S-4	●	●	27	32	250	65		29	21.5				
MGNVR/L 3125R-5	●	●	31	25	200	45		23	19.4				
MGNVR/L 3732S-5	●	●	37	32	250	65	29	21.5	MG*N500	NLJ0516	L4.0		

● Stock ○ Available upon Order

Turning inserts

External turning

Internal turning

Grooving & parting

Threading

Milling

Boring & drilling

Tool holder

Solid carbide end mills

Solid carbide drill & taps

Technical information

FGDHX

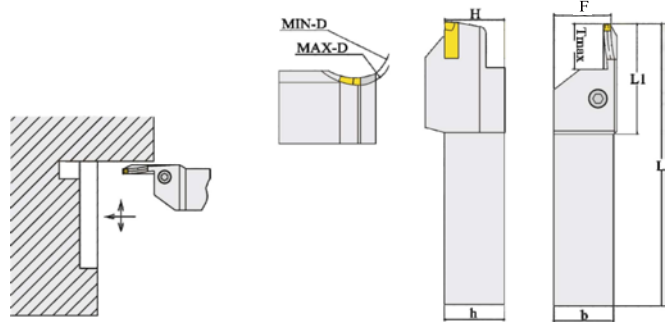

Ordering Code	Stock	Dimensions(mm)							Insert	Screw	Wrench	
	R	h	b	L	F	D	H	T				
FGDHX2020K25/30-3	●	20	20	125	21.8	25-30	20	12	FMM300	NLJ0520	L4.0	
FGDHX2020K30/35-3	●					30-35						
FGDHX2020K35/48-3	●					35-48						
FGDHX2020K48/60-3	●					22			48-60			FGD300
FGDHX2020K60/75-3	●								60-75			
FGDHX2020K75/100-3	●								75-100			
FGDHX2020K100/140-3	●								100-140			
FGDHX2525M25/30-3	●	25	25	150	27.8	25-30	25	FMM300	NLJ0520	L4.0		
FGDHX2525M30/35-3	●					30-35						
FGDHX2525M35/48-3	●					35-48						
FGDHX2525M48/60-3	●					22		48-60			FGD300	
FGDHX2525M60/75-3	●							60-75				
FGDHX2525M75/100-3	●							75-100				
FGDHX2525M100/140-3	●							100-140				
FGDHX2020K25/30-4	●	20	20	125	21.8	25-30	20	FMM400	NLJ0520	L4.0		
FGDHX2020K30/35-4	●					30-35						
FGDHX2020K35/48-4	●					35-48						
FGDHX2020K48/60-4	●					22		48-60			FGD400	
FGDHX2020K60/75-4	●							60-75				
FGDHX2020K75/100-4	●							75-100				
FGDHX2020K100/140-4	●							100-140				
FGDHX2525M25/30-4	●	25	25	150	27.8	25-30	25	FMM400	NLJ0520	L4.0		
FGDHX2525M30/35-4	●					30-35						
FGDHX2525M35/48-4	●					35-48						
FGDHX2525M48/60-4	●					22		48-60			FGD400	
FGDHX2525M60/75-4	●							60-75				
FGDHX2525M75/100-4	●							75-100				
FGDHX2525M100/140-4	●							100-140				
FGDHX2020K25/30-5	●	20	20	125	21.8	25-30	20	FMM500	NLJ0520	L4.0		
FGDHX2020K30/35-5	●					30-35						
FGDHX2020K35/48-5	●					35-48						
FGDHX2020K48/60-5	●					22		48-60			FGD500	
FGDHX2020K60/75-5	●							60-75				
FGDHX2020K75/100-5	●							75-100				
FGDHX2020K100/140-5	●							100-140				
FGDHX2525M25/30-5	●	25	25	150	27.8	25-30	25	FMM500	NLJ0520	L4.0		
FGDHX2525M30/35-5	●					30-35						
FGDHX2525M35/48-5	●					35-48						
FGDHX2525M48/60-5	●					22		48-60			FGD500	
FGDHX2525M60/75-5	●							60-75				
FGDHX2525M75/100-5	●							75-100				
FGDHX2525M100/140-5	●							100-140				

● Stock ○ Available upon Order

Turning inserts

External turning

Internal turning

Grooving & parting

Threading

Milling

Boring & drilling

Tool holder









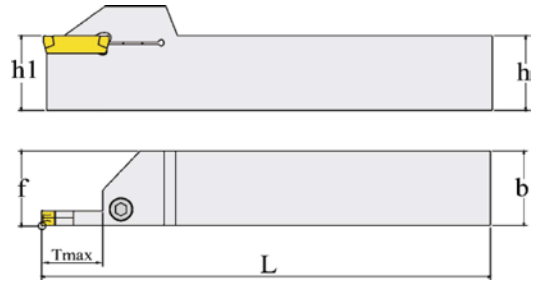

Solid carbide end mills

Solid carbide drill & taps

Technical information

MGEHR/L



Ordering Code	Stock		Dimensions(mm)						Insert	Screw	Screw
	R	L	h	b	L	f	T	h1			
MGEHR/L1616H-2	●	●	16	16	100	16.25	14.5	16	MG*N200		L4.0
MGEHR/L2020K-2	●	●	20	20	125	20.25	14.5	20			
MGEHR/L2020K-2-T10	●	●	20	20	125	20.25	10	20			
MGEHR/L2525M-2	●	●	25	25	150	25.25	14.5	25			
MGEHR/L2525M-2-T10	●	●	25	25	150	25.25	10	25	MG*N250		L4.0
MGEHR/L3232P-2	●	●	32	32	170	32.25	14.5	32			
MGEHR/L1616H-2.5	●	●	16	16	100	16.25	16	16			
MGEHR/L2020K-2.5	●	●	20	20	125	20.25	16	20			
MGEHR/L2020K-2.5-T10	●	●	20	20	125	20.25	10	20	MG*N250		L4.0
MGEHR/L2525M-2.5	●	●	25	25	150	25.25	16	25			
MGEHR/L2525M-2.5-T10	●	●	25	25	150	25.25	10	25			
MGEHR/L3232P-2.5	●	●	32	32	170	32.25	16	32			
MGEHR/L1616H-3	●	●	16	16	100	16.25	18	16	MG*N300		L4.0
MGEHR/L2020K-3	●	●	20	20	125	20.25	18	20			
MGEHR/L2020K-3-T10	●	●	20	20	125	20.25	10	20			
MGEHR/L2525M-3	●	●	25	25	150	25.25	18	25			
MGEHR/L2525M-3-T10	●	●	25	25	150	25.25	10	25	MG*N300		L5.0
MGEHR/L3232P-3	●	●	32	32	170	32.25	18	32			
MGEHR/L3232P-3-T10	●	●	16	16	100	16.25	10	32			
MGEHR/L2020K-4	●	●	20	20	125	20.25	18	20			
MGEHR/L2020K-4-T10	●	●	20	20	125	20.25	10	20	MG*N400		L4.0
MGEHR/L2525M-4	●	●	25	25	150	25.25	18	25			
MGEHR/L2525M-4-T10	●	●	25	25	150	25.25	10	25			
MGEHR/L3232P-4	●	●	32	32	170	32.25	18	32			
MGEHR/L3232P-4-T10	●	●	16	16	100	16.25	10	32	MG*N400		L5.0
MGEHR/L2020K-5	●	●	20	20	125	20.25	23	20			
MGEHR/L2020K-5-T10	●	●	20	20	125	20.25	10	20			
MGEHR/L2525M-5	●	●	25	25	150	25.25	23	25			
MGEHR/L2525M-5-T10	●	●	25	25	150	25.25	10	25	MG*N500		L4.0
MGEHR/L3232P-5	●	●	32	32	170	32.25	23	32			
MGEHR/L3232P-5-T10	●	●	16	16	100	16.25	10	32			
MGEHR/L3232P-5-T10	●	●	16	16	100	16.25	10	32			

● Stock ○ Available upon Order

TTER/L

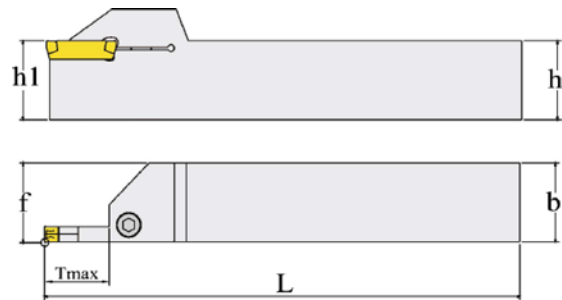

Ordering Code	Stock		Dimensions(mm)						Insert	Screw	Screw
	R	L	h	b	L	F	T	h1			
TTER/L1616H-2	●	●	16	16	100	16.1	12	16	TD*200	NLJ0520	L4.0
TTER/L1616H-2-T17	●	●	20	20	125	16.1	17	20			
TTER/L2020K-2	●	●	20	20	125	20.1	12	20			
TTER/L2020K-2-T17	●	●	25	25	150	20.1	17	25			
TTER/L2525M-2	●	●	25	25	150	25.1	12	25			
TTER/L2525M-2-T17	●	●	32	32	170	32.1	17	32	TD*300	NLJ0520	L4.0
TTER/L1616H-3	●	●	16	16	100	16.25	12	16			
TTER/L1616H-3-T20	●	●	20	20	125	20.25	20	20			
TTER/L2020K-3	●	●	20	20	125	20.25	12	20			
TTER/L2020K-3-T20	●	●	25	25	150	25.25	20	25			
TTER/L2525M-3	●	●	25	25	150	25.25	12	25	TD*400	NLJ0520	L4.0
TTER/L2525M-3-T20	●	●	32	32	170	32.25	20	32			
TTER/L1616H-4	●	●	16	16	100	16.5	15	16			
TTER/L1616H-4-T25	●	●	20	20	125	20.5	25	20			
TTER/L2020K-4	●	●	20	20	125	20.5	15	20			
TTER/L2020K-4-T25	●	●	25	25	150	25.5	25	25	TD*500	NLJ0520	L4.0
TTER/L2525M-4	●	●	25	25	150	25.5	15	25			
TTER/L2525M-4-T25	●	●	32	32	170	32.5	25	32			
TTER/L2020K-5	●	●	20	20	125	20.6	20	20			
TTER/L2020K-5-T25	●	●	25	25	150	25.6	25	25			
TTER/L2525M-5	●	●	25	25	150	25.6	20	25	TD*500	NLJ0520	L4.0
TTER/L2525M-5-T25	●	●	32	32	170	32.6	25	32			

● Stock ○ Available upon Order

Turning inserts

External turning

Internal turning

Grooving & parting

Threading

Milling

Boring & drilling

Tool holder

Solid carbide end mills

Solid carbide drill & taps

Technical information

Thread Cutters

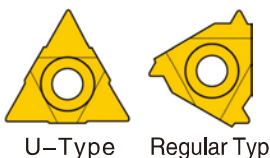

Threading Insert Identification

Insert Size		Application	Hand of Tool
L (mm)	IC	E – External I – Internal UE – U-Type, External UI – U-Type, Internal UEI – U-Type, External and Internal  U-Type Regular Type	R – Right-hand L – Left-hand RL – Right-hand Left-hand
06	3.968mm=5/32"		
08	4.762mm=3/16"		
11	6.350mm=1/4"		
16	9.525mm=3/8"		
22	12.700mm=1/2"		
27	15.875mm=5/8"		

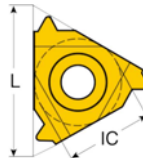
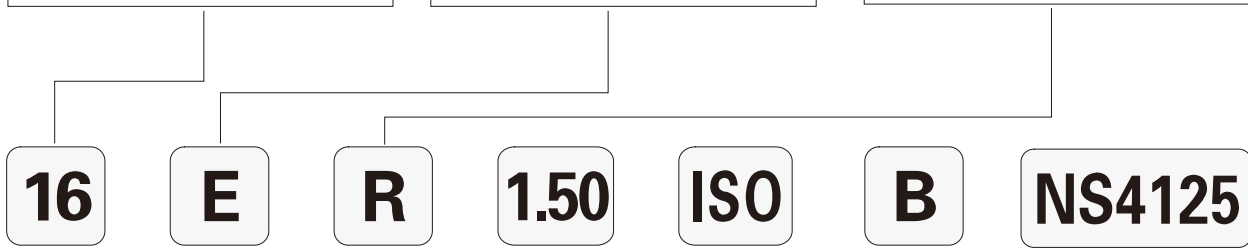
Pitch	Thread Standard	Type	Grade
Full Profile (Value by number) 0.35 – 9.0 mm 72 – 2 TPI Partial Profile (Range by letter) mm TPI A 0.5 – 1.5 48 – 16 AG 0.5 – 3.0 48 – 8 G 1.75 – 3.0 14 – 8 N 3.5 – 5.0 7 – 5 U 5.5 – 9.0 4.5 – 2.75 Q 5.5 – 6.0 4.5 – 4	60 – Partial Profile 60° 55 – Partial Profile 55° ISO – ISO Metric UN – American UN W – Whitworth BSPT – British BSPT RND – Round DIN 405 TR – Trapeze DIN 103 ACME – ACME STACME – Stub ACME ABUT – American Buttress UNJ – UNJ NPT – NPT API RD – API Round BUT – API Buttress Casing API – API	B – Pressed chipbreaker <input type="checkbox"/> – No indication regular type	Coated TT7010 TT8010 TT9030 Uncoated P30

- Turning inserts
- External turning
- Internal turning
- Grooving & parting
- Threading
- Milling
- Boring & drilling
- Tool holder
- Solid carbide end mills
- Solid carbide drill & taps
- Technical information

Threading Cutter Identification

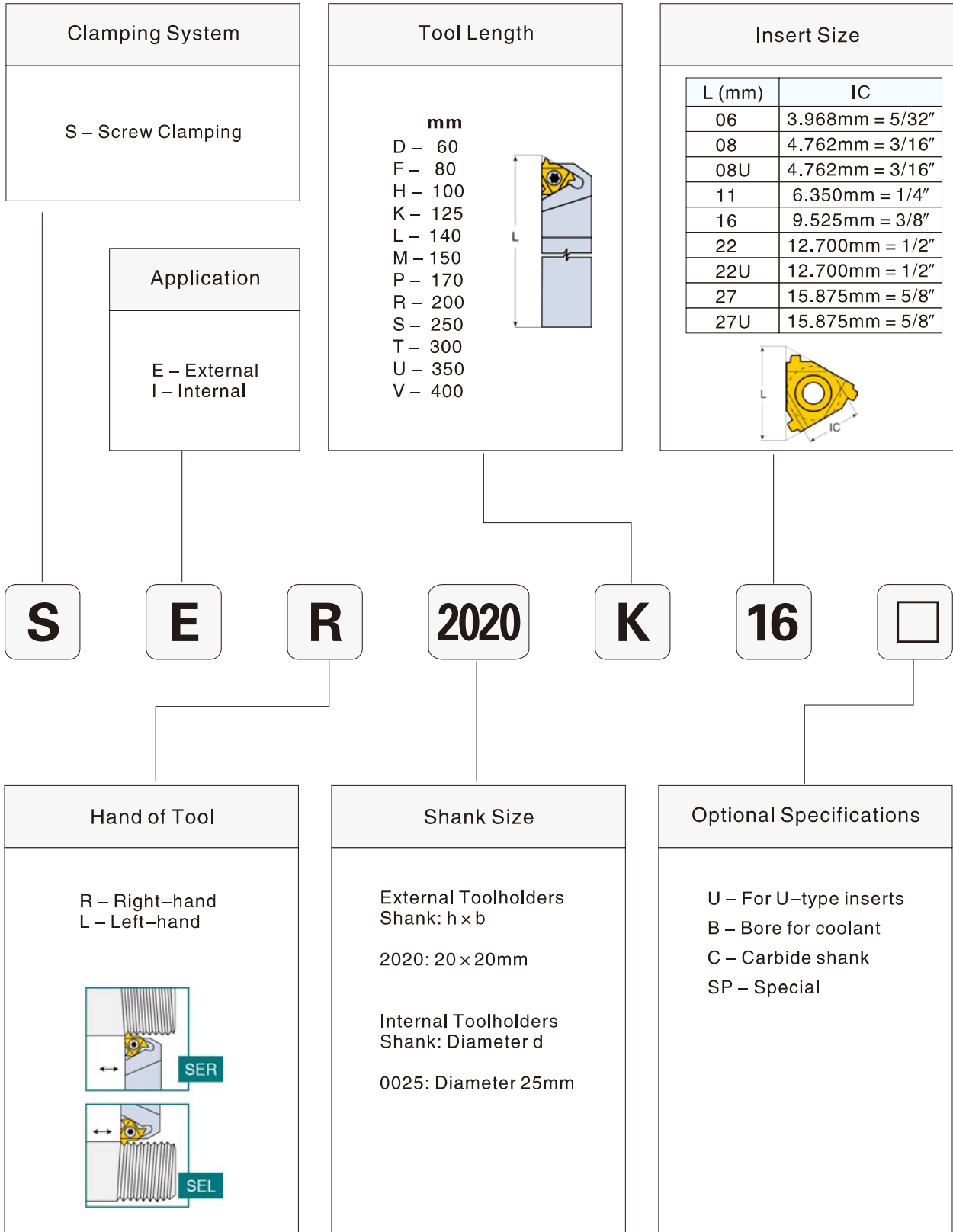

- Turning inserts
- External turning
- Internal turning
- Grooving & parting
- Threading**
- Milling
- Boring & drilling
- Tool holder
- Solid carbide end mills
- Solid carbide drill & taps
- Technical information

USER GUIDE

Threading Inserts – Types and Profiles

Partial Profile

- Suitable for a wide range of pitches with a common angle (60° or 55°)
- Inserts with small root-corner radius suitable for the smallest pitch range.
- Additional operations to complete the outer/internal diameter is necessary.
- Not recommended for mass production.
- Eliminates the need for different inserts.

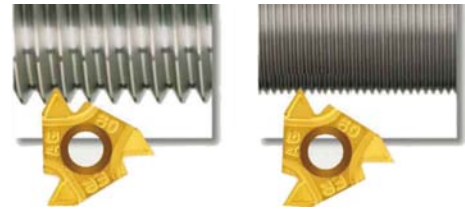

Full Profile

- Performs complete thread profile.
- Root corner radius is suitable only for the relevant pitch.
- Recommended for mass production.
- Suitable for one profile only.

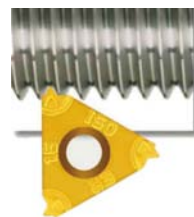

Thread Turning Methods

External Thread

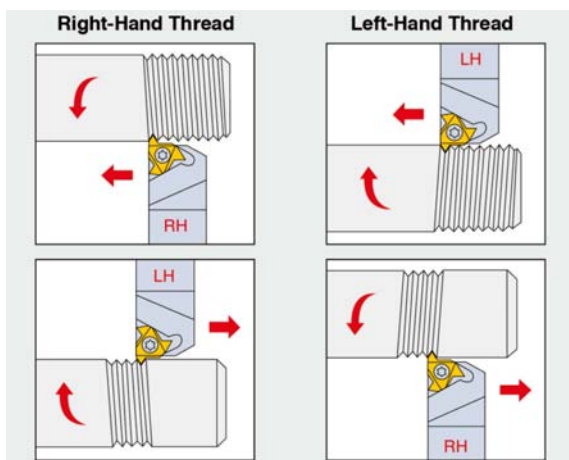

Internal Thread

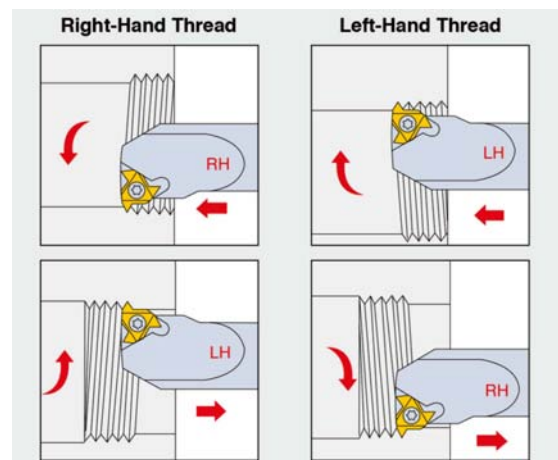

Mini – Tool Features

(1) $\phi D \geq M8$; 5/16"-UN; 1/16"-NPT

(2) 4H-8H/1B-3B

(3) A .00

- (1) Smallest possible thread
- (2) All tolerances
- (3) Minimum run-out
- (4) High surface quality

Insert indexability accuracy: $\pm 0.015\text{mm}$

Threading Insert Features

1. New type of pressing groove, chip processing is good;
2. Special edge treatment, edge uniformity.
3. With NS4125 brand, suitable for steel (P), stainless steel (M), cast iron (K) and other materials.
4. Covered pitch range 1.0–3.0mm.

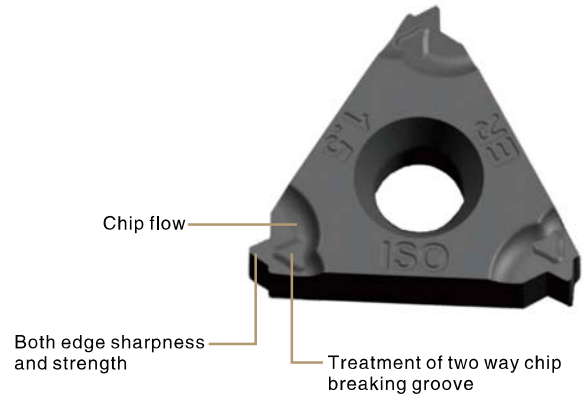

Case Study 1

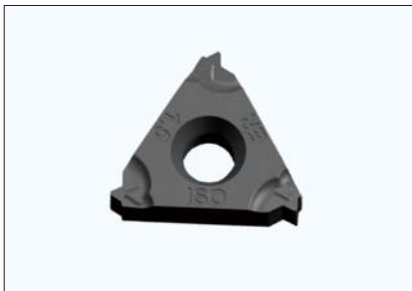

Workpiece material	304(HB200)Stainless steel
Machining parts	Machining external thread
Insert	16ER1,5ISO-B-NS4125

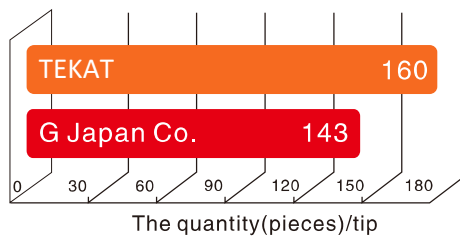

The cutting parameters
 $V_c=110\text{m/min}$
 $\phi d=35\text{mm}$

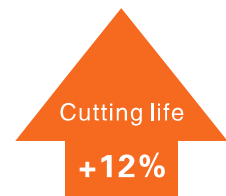

Case Study 2

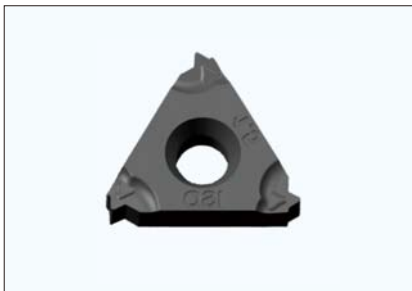

Workpiece material	304(HB200)Stainless steel
Machining parts	Machining internal thread
Insert	16IR1,5ISO-B-NS4125

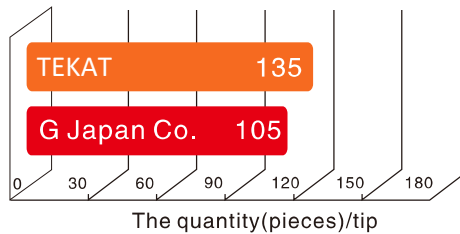

The cutting parameters
 $V_c=90\text{m/min}$
 $\phi d=40\text{mm}$

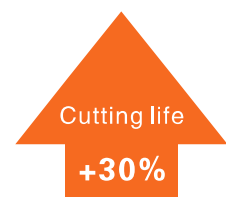

<p>Partial Profile 60°</p>  <p>P142</p>	<p>Partial Profile 55°</p>  <p>P142</p>	<p>Partial Profile 60°</p>  <p>P143</p>	<p>Partial Profile 60°</p>  <p>P143</p>
<p>Partial Profile 55°</p>  <p>P143</p>	<p>Partial Profile 55°</p>  <p>P143</p>	<p>11**ISO</p>  <p>P144</p>	<p>11**ISO-B</p>  <p>P144</p>
<p>16/22**ISO</p>  <p>P144</p>	<p>16**ISO-B</p>  <p>P144</p>	<p>11**UN60°</p>  <p>P145</p>	<p>16/22**UN60°</p>  <p>P145</p>
<p>16**UN-B60°</p>  <p>P145</p>	<p>11**W55°</p>  <p>P146</p>	<p>16/22**W55°</p>  <p>P146</p>	<p>16**W-B55°</p>  <p>P146</p>
<p>11**NPTF60°</p>  <p>P147</p>	<p>16**NPTF60°</p>  <p>P147</p>	<p>11**NPT60°</p>  <p>P147</p>	<p>16**NPT60°</p>  <p>P147</p>
<p>16**NPT-B60°</p>  <p>P147</p>	<p>11**BSPT55°</p>  <p>P148</p>	<p>16**BSPT55°</p>  <p>P148</p>	<p>16**BSPT-B55°</p>  <p>P148</p>

Turning inserts

External turning

Internal turning

Grooving & parting

Threading

Milling

Boring & drilling

Tool holder

Solid carbide end mills

Solid carbide drill & taps

Technical information

Turning inserts

External turning

Internal turning

Grooving & parting

Threading

Milling

Boring & drilling

Tool holder

Solid carbide end mills

Solid carbide drill & taps

Technical information

TR-30° Trapez DIN 103

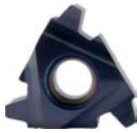

P148

ACME-29° American

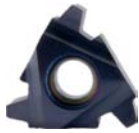

P149

STACME-29°

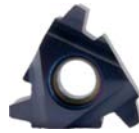

P149

RD30° DIN405



P150

SER/L



P151

CER/L



P151

B-SER/L



P152

MTWHR/L



P152

SNR/L



P153

SNR/L



P153

W-55°



P154

BSPT-55°



P154

ISO Metric full profile



P155

UN-60°



P156

NPT-60°



P157

NPTF



P157

Partial profile 60°



P158

Partial profile 60°



P159

ISO Metric Full Profile



P159

ISO Metric Full Profile



P160

ISO Metric Full Profile



P160

Partial Profile 60° V-style Inserts

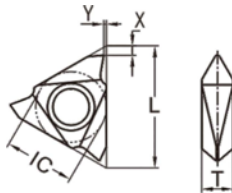
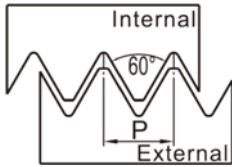

P	Steel	●	●	
M	Stainless Steel		●	
K	Cast Iron		●	
N	Non-ferrous Metal			●
S	Heat-resistant Alloy		●	

Shape	Ordering Code	Pitch		Dimension						CVD	PVD	Uncoated
	ER	mm	TPI	D	S	L	X	Y	R	TS7912	TS4125	TN9115
	TT43R6001	1.0-1.75	24-14	1/2"	4.76	22	1.70	0.29	0.10	●	●	●
	TT43R6002	2.0-2.5	13-10						0.20	●	●	●
	TT43R6003	3.0-3.5	9-7						0.30	●	●	●
	TT43R6004	4.0-4.5	6-5						0.40	●	●	●

Partial Profile 55° V-style Inserts

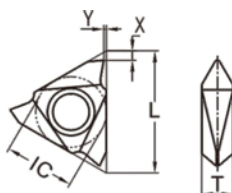
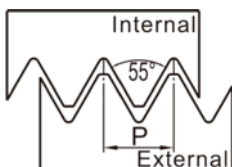

P	Steel	●	●	
M	Stainless Steel		●	
K	Cast Iron		●	
N	Non-ferrous Metal			●
S	Heat-resistant Alloy		●	

Shape	Ordering Code	Pitch		Dimension						CVD	PVD	Uncoated
	ER	mm	TPI	D	S	L	X	Y	R	TS7912	TS4125	TN9115
	TT43R/L5501	1.0-1.75	24-14	1/2"	4.76	22	1.70	0.29	0.10	●	●	●
	TT43R/L5502	2.0-2.5	13-10						0.20	●	●	●
	TT43R/L5503	3.0-3.5	9-7						0.30	●	●	●
	TT43R/L5504	4.0-4.5	6-5						0.40	●	●	●

● Stock ○ Available upon Order

Turning inserts

External turning

Internal turning

Grooving & parting

Threading

Milling

Boring & drilling

Tool holder

Solid carbide end mills

Solid carbide drill & taps

Technical information

Partial Profile 60° Threading Insert



P	Steel	●	●	
M	Stainless Steel		●	
K	Cast Iron		●	
N	Non-ferrous Metal			●
S	Heat-resistant Alloy		●	

Shape	Ordering Code		Pitch		Dimension						CVD	PVD	Uncoated
	ER	IR	mm	TPI	IC	S	L	X	Y	R	TS7912	TS4125	TN9115
		11IR/A60	0.5-1.5	48-16	6.35	3.18	11	0.80	0.90	0.08	●	●	●
	16ER A60	16IR A60	0.5-1.5	48-16	9.525	3.97	16	0.80	0.90	0.08	●	●	●
	16ER AG60	16IR AG60	0.5-3.0	48-8				1.20	1.70	0.08	●	●	●
	16ER G60	16IR G60	1.75-3.0	14-8				1.20	1.70	0.28	●	●	●
	22ER N60	22IR N60	3.5-5.0	7-5	12.7	5.56	22	1.70	2.50	0.53	●	●	●
	16ER A60-B	16IR A60-B	0.5-1.5	48-16	9.525	3.97	16	0.80	0.90	0.08	●	●	●
	16ER AG60-B	16IR AG60-B	0.5-3.0	48-8				1.20	1.70	0.08	●	●	●
	16ER G60-B	16IR G60-B	1.75-3.0	14-8				1.20	1.70	0.18	●	●	●
											●	●	●

Partial Profile 55° Threading Insert



P	Steel	●	●	
M	Stainless Steel		●	
K	Cast Iron		●	
N	Non-ferrous Metal			●
S	Heat-resistant Alloy		●	

Shape	Ordering Code		Pitch		Dimension						CVD	PVD	Uncoated
	ER	IR	mm	TPI	D	S	L	X	Y	R	TS7912	TS4125	TN9115
		11IR/A55	0.5-1.5	48-16	6.35	3.18	11	0.80	0.90	0.08	●	●	●
	16ER A55	16IR A55	0.5-1.5	48-16	9.525	3.97	16	0.80	0.90	0.08	●	●	●
	16ER AG55	16IR AG55	0.5-3.0	48-8				1.20	1.70	0.08	●	●	●
	16ER G55	16IR G55	1.75-3.0	14-8				1.20	1.70	0.28	●	●	●
	22ER N55	22IR N55	3.5-5.0	7-5	12.7	5.56	22	1.70	2.50	0.53	●	●	●
	16ER A55-B	16IR A55-B	0.5-1.5	48-16	9.525	3.97	16	0.80	0.90	0.08	●	●	●
	16ER AG55-B	16IR AG55-B	0.5-3.0	48-8				1.20	1.70	0.08	●	●	●
	16ER G55-B	16IR G55-B	1.75-3.0	14-8				1.20	1.70	0.18	●	●	●
											●	●	●

● Stock ○ Available upon Order

ISO Metric

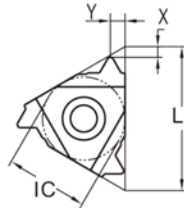
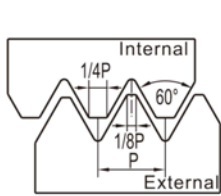

P	Steel	●	●	
M	Stainless Steel		●	
K	Cast Iron		●	
N	Non-ferrous Metal			●
S	Heat-resistant Alloy		●	

Shape	Ordering Code		Pitch		Dimension						CVD	PVD	Uncoated
	ER	IR	mm	TPI	IC	S	L	X	Y	R	TS7912	TS4125	TN9115
		11IR0.50 ISO	0.50		6.35	3.18	11	0.60	0.60	0.05	●	●	●
		11IR0.75 ISO	0.75					0.60	0.60	0.08	●	●	●
		11IR1.00 ISO	1.00					0.70	0.70	0.10	●	●	●
		11IR1.25 ISO	1.25					0.80	0.90	0.13	●	●	●
		11IR1.50 ISO	1.50					0.80	1.0	0.18	●	●	●
		11IR1.75 ISO	1.75					0.80	1.10	0.22	●	●	●
		11IR2.00 ISO	2.00					-	-	0.25	●	●	●
		11IR0.50 ISO-B	0.50		6.35	3.18	11	0.60	0.60	0.05	●	●	●
		11IR0.75 ISO-B	0.75					0.60	0.60	0.08	●	●	●
		11IR1.00 ISO-B	1.00					0.70	0.70	0.10	●	●	●
		11IR1.25 ISO-B	1.25					0.80	0.90	0.13	●	●	●
		11IR1.50 ISO-B	1.50					0.80	1.0	0.18	●	●	●
		11IR1.75 ISO-B	1.75					0.80	1.10	0.22	●	●	●
		11IR2.00 ISO-B	2.00					-	-	0.25	●	●	●
		16ER0.50 ISO	16IR0.50 ISO	0.50	9.525	3.97	16	0.60	0.60	0.05	●	●	●
		16ER0.75 ISO	16IR0.75 ISO	0.75				0.60	0.60	0.08	●	●	●
		16ER1.00 ISO	16IR1.00 ISO	1.00				0.70	0.70	0.10	●	●	●
		16ER1.25 ISO	16IR1.25 ISO	1.25				0.80	0.90	0.13	●	●	●
		16ER1.50 ISO	16IR1.50 ISO	1.50				0.80	1.0	0.18	●	●	●
		16ER1.75 ISO	16IR1.75 ISO	1.75				0.90	1.20	0.22	●	●	●
		16ER2.00 ISO	16IR2.00 ISO	2.00				1.0	1.30	0.25	●	●	●
		16ER2.50 ISO	16IR2.50 ISO	2.50				1.10	1.50	0.30	●	●	●
		22ER3.50 ISO	22IR/L3.50 ISO	3.50	12.7	5.56	22	1.60	2.30	0.38	●	●	●
		22ER4.00 ISO	22IR/L4.00 ISO	4.00				1.60	2.30	0.40	●	●	●
		22ER4.50 ISO	22IR/L4.50 ISO	4.50				1.70	2.40	0.40	●	●	●
		22ER5.00 ISO	22IR/L5.00 ISO	5.00				1.70	2.40	0.40	●	●	●
		16ER0.50 ISO-B	16IR0.50 ISO-B	0.50	9.525	3.97	16	0.60	0.60	0.05	●	●	●
		16ER0.75 ISO-B	16IR0.75 ISO-B	0.75				0.60	0.60	0.08	●	●	●
		16ER1.00 ISO-B	16IR1.00 ISO-B	1.00				0.70	0.70	0.10	●	●	●
		16ER1.25 ISO-B	16IR1.25 ISO-B	1.25				0.80	0.90	0.13	●	●	●
		16ER1.50 ISO-B	16IR1.50 ISO-B	1.50				0.80	1.0	0.18	●	●	●
		16ER1.75 ISO-B	16IR1.75 ISO-B	1.75				0.90	1.20	0.22	●	●	●
		16ER2.00 ISO-B	16IR2.00 ISO-B	2.00				1.0	1.30	0.25	●	●	●
		16ER2.50 ISO-B	16IR2.50 ISO-B	2.50				1.10	1.50	0.30	●	●	●
		16ER3.00 ISO-B	16IR3.00 ISO-B	3.00				1.20	1.60	0.36	●	●	●

● Stock ○ Available upon Order

Turning inserts

External turning

Internal turning

Grooving & parting

Threading

Milling

Boring & drilling

Tool holder

Solid carbide end mills

Solid carbide drill & taps

Technical information

60° American UN NC NF NEF NS



P	Steel	●	●	
M	Stainless Steel		●	
K	Cast Iron		●	
N	Non-ferrous Metal			●
S	Heat-resistant Alloy		●	

Shape	Ordering Code		Pitch		Dimension						CVD	PVD	Uncoated			
	ER	IR	mm	TPI	D	S	L	X	Y	R	TS7912	TS4125	TN9115			
		11IR32 UN		32	6.36	3.18	11	0.60	0.60	0.10	●	●	●			
		11IR28 UN		28				0.60	0.70	0.10	●	●	●			
		11IR24 UN		24				0.70	0.80	0.13	●	●	●			
		11IR20 UN		20				0.80	0.90	0.15	●	●	●			
		11IR18 UN		18				0.80	1.0	0.18	●	●	●			
		11IR16 UN		16				0.90	1.10	0.20	●	●	●			
	16ER32 UN	16IR32 UN		32	9.525	3.97	16	0.60	0.60	0.08	●	●	●			
	16ER28 UN	16IR28 UN		28				0.60	0.70	0.08	●	●	●			
	16ER24 UN	16IR24 UN		24				0.70	0.80	0.10	●	●	●			
	16ER20 UN	16IR20 UN		20				0.80	0.90	0.10	●	●	●			
	16ER18 UN	16IR18 UN		18				0.80	1.0	0.13	●	●	●			
	16ER16 UN	16IR16 UN		16				0.9	1.1	0.15	●	●	●			
	16ER14 UN	16IR14 UN		14				1.0	1.2	0.18	●	●	●			
	16ER13 UN	16IR13 UN		13				1.1	1.3	0.20	●	●	●			
	16ER12 UN	16IR12 UN		12				1.1	1.4	0.23	●	●	●			
	16ER11.5 UN	16IR11.5 UN		11.5				1.1	1.4	0.25	●	●	●			
	16ER11 UN	16IR11 UN		11				1.1	1.5	0.28	●	●	●			
	16ER10 UN	16IR10 UN		10				1.1	1.5	0.30	●	●	●			
	16ER9 UN	16IR 9 UN		9				1.2	1.7	0.33	●	●	●			
	16ER8 UN	16IR8 UN		8				1.2	2.0	0.36	●	●	●			
	22ER7 UN	22IR7 UN		7				12.7	5.56	22	1.60	2.30	0.38	●	●	●
	22ER6 UN	22IR6 UN		6							1.60	2.30	0.41	●	●	●
22ER5 UN	22IR5 UN		5	1.70	2.50	0.43	●				●	●				
	16ER32 UN-B	16IR32 UN-B		32	9.525	3.97	16	0.60	0.60	0.08	●	●	●			
	16ER28 UN-B	16IR28 UN-B		28				0.60	0.70	0.08	●	●	●			
	16ER24 UN-B	16IR24 UN-B		24				0.70	0.80	0.10	●	●	●			
	16ER20 UN-B	16IR20 UN-B		20				0.80	0.90	0.10	●	●	●			
	16ER18 UN-B	16IR18 UN-B		18				0.80	1.0	0.13	●	●	●			
	16ER16 UN-B	16IR16 UN-B		16				0.9	1.1	0.15	●	●	●			
	16ER14 UN-B	16IR14 UN-B		14				1.0	1.2	0.18	●	●	●			
	16ER13 UN-B	16IR13 UN-B		13				1.1	1.3	0.20	●	●	●			
	16ER12 UN-B	16IR12 UN-B		12				1.1	1.4	0.23	●	●	●			
	16ER11.5 UN-B	16IR11.5 UN-B		11.5				1.1	1.4	0.25	●	●	●			
	16ER11 UN-B	16IR11 UN-B		11				1.1	1.5	0.28	●	●	●			
	16ER10 UN-B	16IR10 UN-B		10				1.1	1.5	0.30	●	●	●			
	16ER9 UN-B	16IR 9 UN-B		9				1.2	1.7	0.33	●	●	●			
	16ER8 UN-B	16IR8 UN-B		8				1.2	2.0	0.36	●	●	●			

● Stock ○ Available upon

- Turning inserts
- External turning
- Internal turning
- Grooving & parting
- Threading
- Milling
- Boring & drilling
- Tool holder
- Solid carbide end mills
- Solid carbide drill & taps
- Technical information

55° Whitworth Full Profile

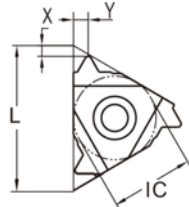
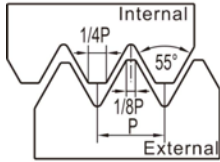

P	Steel	●	●	
M	Stainless Steel		●	
K	Cast Iron		●	
N	Non-ferrous Metal			●
S	Heat-resistant Alloy		●	

Shape	Ordering Code		Pitch		Dimension						CVD	PVD	Uncoated			
	ER	IR	mm	TPI	D	S	L	X	Y	R	TS7912	TS4125	TN9115			
		11IR28 W		28	6.35	3.18	11	0.60	0.70	0.08	●	●	●			
		11IR26 W		26				0.70	0.80	0.08	●	●	●	●	●	
		11IR24 W		24				0.70	0.80	0.08	●	●	●	●	●	
		11IR20 W		20				0.80	0.90	0.10	●	●	●	●	●	
		11IR19 W		19				0.80	1.00	0.15	●	●	●	●	●	
		11IR18 W		18				0.90	1.00	0.20	●	●	●	●	●	
		11IR16 W		16				0.90	1.10	0.23	●	●	●	●	●	
		11IR14 W		14				1.00	1.20	0.25	●	●	●	●	●	
	16ER28 W	16IR28 W		28	9.525	3.97	16	0.60	0.70	0.08	●	●	●			
	16ER26 W	16IR26 W		26				0.70	0.80	0.08	●	●	●	●	●	
	16ER24 W	16IR24 W		24				0.70	0.80	0.08	●	●	●	●	●	
	16ER20 W	16IR20 W		20				0.80	0.90	0.10	●	●	●	●	●	
	16ER19 W	16IR19 W		19				0.80	1.00	0.15	●	●	●	●	●	
	16ER18 W	16IR18 W		18				0.80	0.90	0.20	●	●	●	●	●	
	16ER16 W	16IR16 W		16				0.90	1.10	0.23	●	●	●	●	●	
	16ER14 W	16IR14 W		14				0.90	1.20	0.25	●	●	●	●	●	
	16ER12 W	16IR12 W		12				1.10	1.40	0.28	●	●	●	●	●	
	16ER11 W	16IR11 W		11				1.10	1.50	0.30	●	●	●	●	●	
	16ER10 W	16IR10 W		10				1.10	1.50	0.33	●	●	●	●	●	
	16ER9 W	16IR9 W		9				1.20	1.50	0.33	●	●	●	●	●	
	16ER8 W	16IR8 W		8				1.20	1.70	0.36	●	●	●	●	●	
	22ER7 W	22IR7 W		7				12.7	5.56	22	1.60	2.30	0.36	●	●	●
	22ER6 W	22IR6 W		6							1.60	2.30	0.38	●	●	●
22ER5 W	22IR5 W		5	1.70	2.40	0.41	●				●	●	●	●		
	16ER28 W-B	16IR28 W-B		28	9.525	3.97	16	0.60	0.70	0.08	●	●	●			
	16ER26 W-B	16IR26 W-B		26				0.70	0.80	0.08	●	●	●	●	●	
	16ER20 W-B	16IR20 W-B		20				0.80	0.90	0.10	●	●	●	●	●	
	16ER19 W-B	16IR19 W-B		19				0.80	1.00	0.15	●	●	●	●	●	
	16ER18 W-B	16IR18 W-B		18				0.80	0.90	0.20	●	●	●	●	●	
	16ER16 W-B	16IR16 W-B		16				0.90	1.10	0.23	●	●	●	●	●	
	16ER14 W-B	16IR14 W-B		14				0.90	1.20	0.25	●	●	●	●	●	
	16ER12 W-B	16IR12 W-B		12				1.10	1.40	0.28	●	●	●	●	●	
	16ER11 W-B	16IR11 W-B		11				1.10	1.50	0.30	●	●	●	●	●	
	16ER10 W-B	16IR10 W-B		10				1.10	1.50	0.33	●	●	●	●	●	
	16ER9 W-B	16IR9 W-B		9				1.20	1.50	0.33	●	●	●	●	●	
	16ER8 W-B	16IR8 W-B		8				1.20	1.70	0.36	●	●	●	●	●	

● Stock ○ Available upon Order

Turning inserts

External turning

Internal turning

Grooving & parting

Threading

Milling

Boring & drilling

Tool holder

Solid carbide end mills

Solid carbide drill & taps

Technical information

60° NPTF

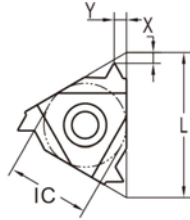
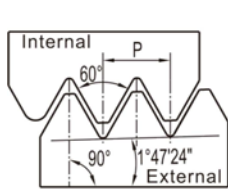

P	Steel	●	●	
M	Stainless Steel		●	
K	Cast Iron		●	
N	Non-ferrous Metal			●
S	Heat-resistant Alloy		●	

Shape	Ordering Code		Pitch		Dimension						CVD	PVD	Uncoated		
	ER	IR	mm	TPI	D	S	L	X	Y	R	TS7912	TS4125	TN9115		
		11IR27 NPTF	27		6.35	3.18	11	0.70	0.80	0.08	●	●	●		
		11IR18 NPTF	18					0.80	1.00	0.10	●	●	●	●	●
		11IR14 NPTF	14					0.80	1.00	0.13	●	●	●	●	●
	16ER27 NPTF	16IR27 NPTF	27		9.525	3.97	16	0.70	0.80	0.08	●	●	●		
	16ER18 NPTF	16IR18 NPTF	18					0.80	1.00	0.10	●	●	●	●	●
	16ER14 NPTF	16IR14 NPTF	14					0.90	1.20	0.13	●	●	●	●	●
	16ER11.5 NPTF	16IR11.5 NPTF	11.5					1.10	1.50	0.18	●	●	●	●	●
	16ER8 NPTF	16IR8 NPTF	8					1.30	1.80	0.23	●	●	●	●	●

60° NPT

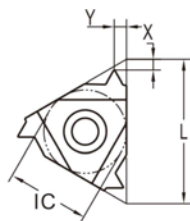
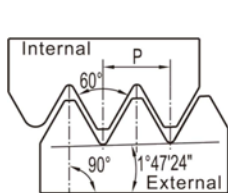

P	Steel	●	●	
M	Stainless Steel		●	
K	Cast Iron		●	
N	Non-ferrous Metal			●
S	Heat-resistant Alloy		●	

Shape	Ordering Code		Pitch		Dimension						CVD	PVD	Uncoated		
	ER	IR	mm	TPI	D	S	L	X	Y	R	TS7912	TS4125	TN9115		
		11IR27 NPT	27		6.35	3.18	11	0.70	0.80	0.08	●	●	●		
		11IR18 NPT	18					0.80	1.00	0.10	●	●	●	●	●
		11IR14 NPT	14					0.80	1.00	0.15	●	●	●	●	●
	16ER27 NPT	16IR27 NPT	27		9.525	3.97	16	0.70	0.80	0.08	●	●	●		
	16ER18 NPT	16IR18 NPT	18					0.80	1.00	0.10	●	●	●	●	●
	16ER14 NPT	16IR14 NPT	14					0.90	1.20	0.15	●	●	●	●	●
	16ER11.5 NPT	16IR11.5 NPT	11.5					1.10	1.50	0.20	●	●	●	●	●
	16ER8 NPT	16IR8 NPT	8					1.20	1.80	2.54	●	●	●	●	●
	16ER27 NPT-B	16IR27 NPT-B	27		9.525	3.97	16	0.70	0.80	0.80	●	●	●		
	16ER18 NPT-B	16IR18 NPT-B	18					0.80	1.00	0.15	●	●	●	●	●
	16ER14 NPT-B	16IR14 NPT-B	14					0.90	1.20	0.20	●	●	●	●	●
	16ER11.5 NPT-B	16IR11.5 NPT-B	11.5					1.10	1.50	0.25	●	●	●	●	●

● Stock ○ Available upon Order

55° BSPT

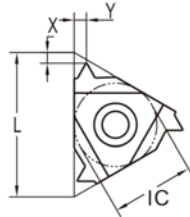
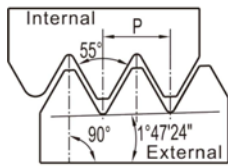

P	Steel	●	●	
M	Stainless Steel		●	
K	Cast Iron		●	
N	Non-ferrous Metal			●
S	Heat-resistant Alloy		●	

Shape	Ordering Code		Pitch		Dimension						CVD	PVD	Uncoated
	ER	IR	mm	TPI	D	S	L	X	Y	R	TS7912	TS4125	TN9115
		11IR28 BSPT		28	6.35	3.18	11	0.60	0.60	0.08	●	●	●
		11IR19 BSPT		19				0.80	0.90	0.10	●	●	●
		11IR14 BSPT		14				0.90	1.00	0.15	●	●	●
	16ER28 BSPT	16IR28 BSPT		28	9.525	3.97	16	0.60	0.60	0.08	●	●	●
	16ER19 BSPT	16IR19 BSPT		19				0.80	0.90	0.10	●	●	●
	16ER14 BSPT	16IR14 BSPT		14				1.00	1.20	0.15	●	●	●
	16ER11 BSPT	16IR11 BSPT		11				1.10	1.50	0.18	●	●	●
	16ER28 BSPT-B	16IR28 BSPT-B		28	9.525	3.97	16	0.60	0.60	0.08	●	●	●
	16ER19 BSPT-B	16IR19 BSPT-B		19				0.80	0.90	0.10	●	●	●
	16ER14 BSPT-B	16IR14 BSPT-B		14				1.00	1.20	0.15	●	●	●
	16ER11 BSPT-B	16IR11 BSPT-B		11				1.10	1.50	0.18	●	●	●

TR-30° Trapez DIN 103

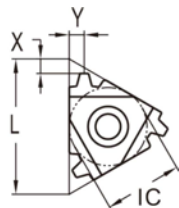
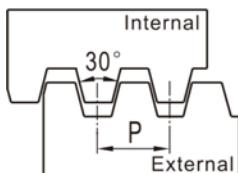

P	Steel	●	●	
M	Stainless Steel		●	
K	Cast Iron		●	
N	Non-ferrous Metal			●
S	Heat-resistant Alloy		●	

Shape	Ordering Code		Pitch		Dimension						CVD	PVD	Uncoated
	ER	IR	mm	TPI	D	S	L	X	Y	R	TS7912	TS4125	TN9115
	16ER1.5TR	16IR1.5TR		1.5	9.525	3.97	16	1.04	1.94	0.08	●	●	●
	16ER2.0TR	16IR2.0TR		2.0				1.30	2.58	0.10	●	●	●
	16ER3.0TR	16IR3.0TR		3.0				1.50	3.87	0.15	●	●	●
	22ER4.0TR	22IR4.0TR		4.0	12.7	5.56	22	1.91	5.16	0.20	●	●	●
	22ER5.0TR	22IR5.0TR		5.0				2.49	5.81	0.23	●	●	●
	22ER6.0TR	22IR6.0TR		6.0				2.57	7.10	0.28	●	●	●
	22ER7.0TR	22IR7.0TR		7.0				2.41	7.74	0.30	●	●	●

● Stock ○ Available upon Order

Turning inserts

External turning

Internal turning

Grooving & parting

Threading

Milling

Boring & drilling

Tool holder

Solid carbide end mills

Solid carbide drill & taps

Technical information

ACME-29° American

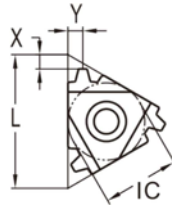
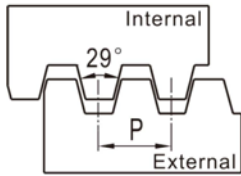

P	Steel	●	●	
M	Stainless Steel		●	
K	Cast Iron		●	
N	Non-ferrous Metal			●
S	Heat-resistant Alloy		●	

Shape	Ordering Code		Pitch		Dimension						CVD	PVD	Uncoated
	ER	IR	mm	TPI	D	S	L	X	Y	R	TS7912	TS4125	TN9115
	16ER16ACME	16IR16ACME	16.0		9.525	3.97	16	1.09	0.99	0.08	●	●	●
	16ER14ACME	16IR14ACME	14.0					1.09	0.99	0.10	●	●	●
	16ER12ACME	16IR12ACME	12.0					1.19	1.09	0.15	●	●	●
	16ER10ACME	16IR10ACME	10.0					1.40	1.30	0.20	●	●	●
	16ER8ACME	16IR8ACME	10.0					1.50	1.40	0.23	●	●	●
	22ER6ACME	22IR6ACME	8.0		12.7	5.56	22	2.11	1.80	0.28	●	●	●
	22ER5ACME	22IR5ACME	5.0					2.29	2.01	0.41	●	●	●
	22ER4ACME	22IR4ACME	4.0					2.84	2.34	0.53	●	●	●

STACME-29° American Stub ACME

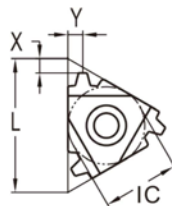
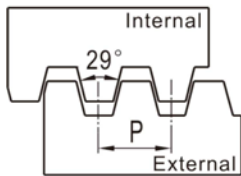

P	Steel	●	●	
M	Stainless Steel		●	
K	Cast Iron		●	
N	Non-ferrous Metal			●
S	Heat-resistant Alloy		●	

Shape	Ordering Code		Pitch		Dimension						CVD	PVD	Uncoated
	ER	IR	mm	TPI	D	S	L	X	Y	R	TS7912	TS4125	TN9115
	16ER16STACME	16IR16STACME	16.0		9.525	3.97	16	0.99	0.99	0.08	●	●	●
	16ER14STACME	16IR14STACME	14.0					0.99	0.99	0.10	●	●	●
	16ER12STACME	16IR12STACME	12.0					1.30	1.19	0.15	●	●	●
	16ER10STACME	16IR10STACME	10.0					1.30	1.19	0.20	●	●	●
	16ER8STACME	16IR8STACME	10.0					1.50	1.40	0.23	●	●	●
	22ER6STACME	22IR6STACME	8.0		12.7	5.56	22	1.50	1.40	0.28	●	●	●
	22ER5STACME	22IR5STACME	5.0					2.29	2.11	0.41	●	●	●
	22ER4STACME	22IR4STACME	4.0					2.51	2.21	0.53	●	●	●

● Stock ○ Available upon Order

RD30° DIN405

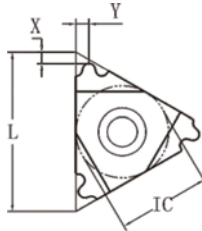
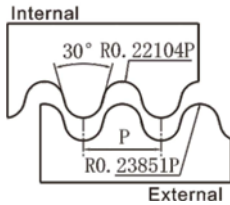

P	Steel	●	●	
M	Stainless Steel		●	
K	Cast Iron		●	
N	Non-ferrous Metal			●
S	Heat-resistant Alloy		●	

Shape	Ordering Code		Pitch		Dimension						CVD	PVD	Uncoated
	ER	IR	mm	TPI	D	S	L	X	Y	R	TS7912	TS4125	TN9115
	16ER10RD	16IR10RD	10.0		9.525	3.97	16	1.30	1.40	0.61	●	●	●
	16ER8RD	16IR8RD	8.0					1.50	1.60	0.76	●	●	●
	16ER6RD	16IR6RD	6.0					1.70	1.50	1.02	●	●	●
	22ER6RD	22IR6RD	6.0		12.7	5.56	22	1.70	1.50	1.02	●	●	●
	22ER4RD	22IR4RD	4.0					2.34	2.21	1.50	●	●	●
	22ER4RD	22IR4RD	4.0								●	●	●

● Stock ○ Available upon Order

Processing parameter list of screw blade

Material	Carbon steel S50C, Q235		Alloy steel 25-35HRC 4Cr5MoSiV1, Cr12		Stainless steel SUS304, 316, 0Cr19Ni9		Cast iron HT250, QT450		Aluminium alloy	
	Vc=m/min	ap=mm	Vc=m/min	ap=mm	Vc=m/min	ap=mm	Vc=m/min	ap=mm	Vc=m/min	ap=mm
External thread	100-150	<0.3	100-150	<0.3	60-80	<0.2	80-120	<0.3	150-300	<0.3
Internal thread										

Turning inserts

External turning

Internal turning

Grooving & parting

Threading

Milling

Boring & drilling

Tool holder

Solid carbide end mills

Solid carbide drill & taps

Technical information

SER/L

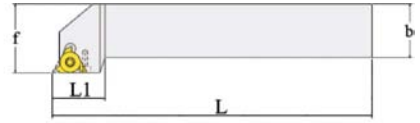
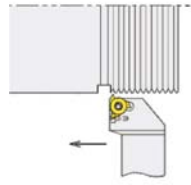
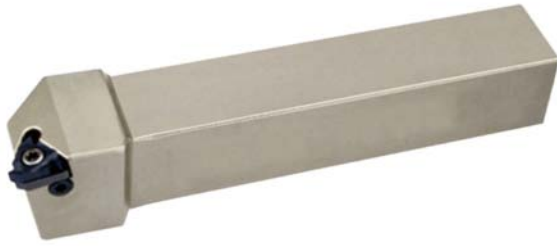

Ordering Code	Stock		Dimensions(mm)						Insert	Knife pad	Screw	Screw	Wrench
	R	L	h	b	L	L1	h1	f					
SER/L 1212K16	●	●	12	12	100	20	12	16	16ER/L	DP16ER/L	NLJ0308	M3.5*12	T15
SER/L 1616H16	●	●	16	16	100	22	16	20					
SER/L 2020K16	●	●	20	20	125	25	20	25					
SER/L 2525M16	●	●	25	25	150	30	25	32					
SER/L 3232P16	●	●	32	32	170	35	32	40					

CER/L

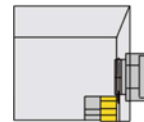

Ordering Code	Stock		Dimensions(mm)						Insert	Knife pad	Screw	Pressing plate	Screw	Screw	Wrench
	R	L	h	b	L	L1	h1	f							
CER/L 2525M22	●	●	25	25	150	30	25	32	22ER/L	DP22ER/L	NLJ0410	MYB1814	ST0625	M3.5*12	T15
CER/L 3232P22	●	●	32	32	170	35	32	40							

● Stock ○ Available upon Order

Turning inserts

External turning

Internal turning

Grooving & parting

Threading

Milling

Boring & drilling

Tool holder

Solid carbide end mills

Solid carbide drill & taps

Technical information

B-SER/L

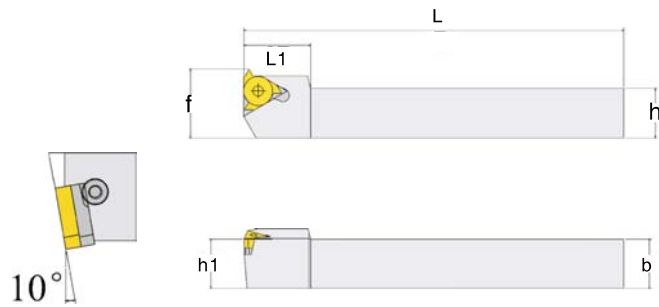
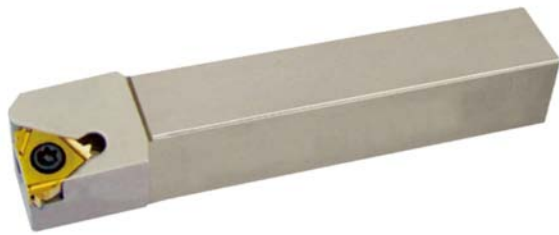

Ordering Code	Stock		Dimensions(mm)						Insert	Knife pad	Screw	Screw	Wrench
	R	L	h	b	L	L1	h1	f					
B-SER/L 1212K16	●	●	12	12	100	20	12	16	16ER/L	DP16ER/L	NLJ0308	M3.5*12	T15
B-SER/L 1616H16	●	●	16	16	100	22	16	20					
B-SER/L 2020K16	●	●	20	20	125	25	20	25					
B-SER/L 2525M16	●	●	25	25	150	30	25	32					

MTWHR/L

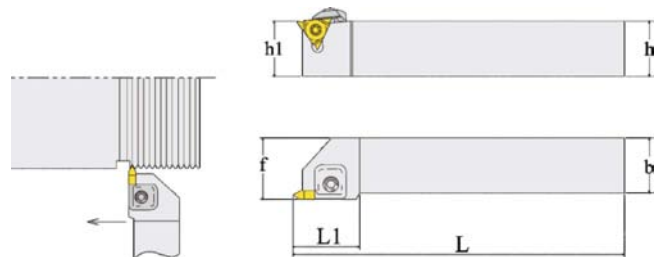

Ordering Code	Stock		Dimensions(mm)						Insert	Screw	Screw	Wrench	Pressing plate	Spring
	R	L	h	b	L	L1	h1	f						
MTWHR/L 1616H16	●	●	16	16	100	22	16	20	TT43	NLJ0520	L4.0 T15	M4*12	YB1318	DTH0814
MTWHR/L 2020K16	●	●	20	20	125	25	20	25						
MTWHR/L 2525M16	●	●	25	25	150	30	25	32						
MTWHR/L 3232P16	●	●	32	32	170	35	32	40						

● Stock ○ Available upon Order

Turning inserts

External turning

Internal turning

Grooving & parting

Threading

Milling

Boring & drilling

Tool holder

Solid carbide end mills

Solid carbide drill & taps

Technical information

SNR/L

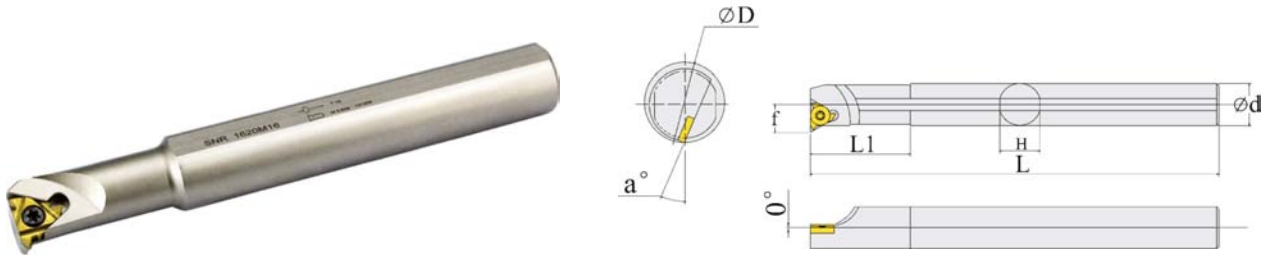

Ordering Code	Stock		Dimensions(mm)							Insert	Screw	Screw
	R	L	D	d	H	L	L1	f	a°			
SNR/L 0716M08	●	●	10	16	15	150	18	5.7	15	08IR	M2.2*6	T-6
SNR/L 0816M08	●	●	11	16	15	150	20	6.2	15			
SNR/L 0916M08	●	●	12	16	15	150	23	6.7	17			
SNR/L 1016M08	●	●	13	16	15	150	25	7.2	17			
SNR/L 1016M11	●	●	13	16	15	150	22	7.7	15	11IR/L	M2.5*6	T-8
SNR/L 1316M11	●	●	16	16	15	150	32	8.7	15			
SNR/L 1020M11	●	●	13	20	18	150	32	7.7	21			
SNR/L 1316M16	●	●	16	16	15	150	32	8.7	21	16IR/L	M3.5*10	T-15
SNR/L 1620M16	●	●	20	32	18	150	40	11.7	15			

SNR/L

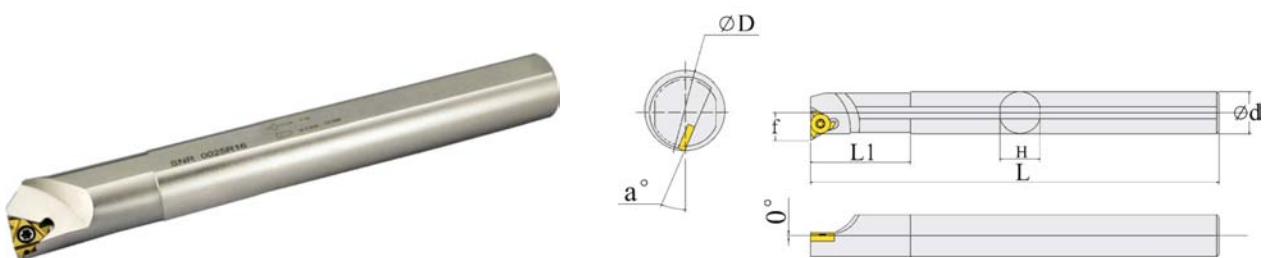

Ordering Code	Stock		Dimensions(mm)							Insert	Screw	Screw
	R	L	D	d	H	L	L1	f	a°			
SNR/L 0010K11	●	●	13	10	9	125	22	7.2	15	11IR/L	M2.5*6	T-8
SNR/L 0012M11	●	●	15	12	11	150	22	7.8	15			
SNR/L 0013M11	●	●	16	13	12	150	32	8.5	17			
SNR/L 0013M16	●	●	16	13	12	150	32	10.2	17	16IR/L	M3.5*8	T-15
SNR/L 0016M16	●	●	19	16	15	150	40	11.7	15			
SNR/L 0016Q16	●	●	19	16	15	180	40	11.7	15			
SNR/L 0020Q16	●	●	24	20	18	180	40	13.7	21			
SNR/L 0025R16	●	●	29	25	23	200	45	16.2	21			
SNR/L 0032S16	●	●	36	32	29	250	50	19.7	15			

● Stock ○ Available upon Order

Turning inserts

External turning

Internal turning

Grooving & parting

Threading

Milling

Boring & drilling

Tool holder

Solid carbide end mills

Solid carbide drill & taps

Technical information

W-55° Whitworth full profile

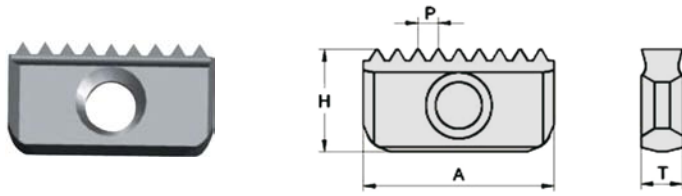

P	Steel	●	●	
M	Stainless Steel		●	
K	Cast Iron		●	
N	Non-ferrous Metal			●
S	Heat-resistant Alloy		●	

Pitch	Dimension					CVD	PVD	Uncoated
TPI	12mm	14mm	21mm	30mm	40mm	TS7912	TS4125	TN9115
24		14-24W				●	●	○
20		14-20W	21-20W			●	●	○
19	*12I-19W	14-19W	21-19W			●	●	○
16		14-16W	21-16W	30-16W		●	●	○
14		14-14W	21-14W	30-14W		●	●	○
11			21-11W	30-11W	40-11W	●	●	○
8					40-8W	●	●	○
H	6.3	7.5	12	16	20			
T	2.9	3.1	4.7	5.5	6.3			

BSPT-55° British standard full profile

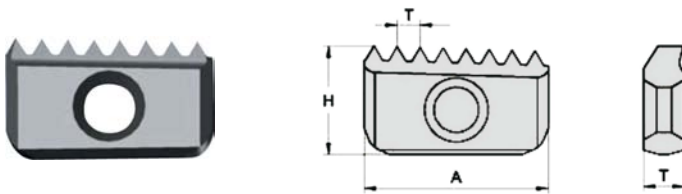

P	Steel	●	●	
M	Stainless Steel		●	
K	Cast Iron		●	
N	Non-ferrous Metal			●
S	Heat-resistant Alloy		●	

Pitch	Dimension					CVD	PVD	Uncoated
TPI	12mm	14mm	21mm	30mm	40mm	TS7912	TS4125	TN9115
19	*12I-19BSPT	14-19BSPT				○	●	○
14		14-14BSPT	21-14BSPT			○	●	○
11			21-11BSPT	30-11BSPT	40-11BSPT	○	●	○
H	6.3	7.5	12	16	20			
T	2.9	3.1	4.7	5.5	6.3			

ISO Metric full profile

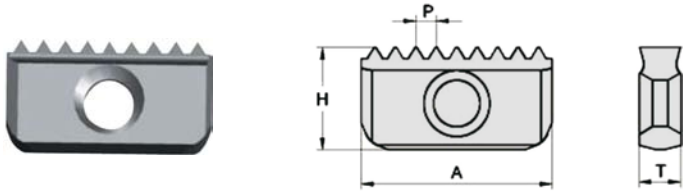

P	Steel	●	●	
M	Stainless Steel		●	
K	Cast Iron		●	
N	Non-ferrous Metal			●
S	Heat-resistant Alloy		●	

Pitch	Dimension					CVD	PVD	Uncoated
	12mm	14mm	21mm	30mm	40mm			
TPI						TS7912	TS4125	TN9115
0.5	*12I-0.5 ISO	14I-0.5 ISO				●	●	○
0.75	*12I-0.75 ISO	14E/I-0.75 ISO				●	●	○
1	*12I-1.0 ISO	14E/I-1.0 ISO	21E/I-1.0 ISO			●	●	○
1.25	*12I-1.25 ISO	14E/I-1.25 ISO				●	●	○
1.5	*12I-1.5 ISO	14E/I-1.5 ISO	21E/I-1.5 ISO	30E/I-1.5 ISO	40E/I-1.5 ISO	●	●	○
1.75		14E/I-1.75 ISO	21I-1.75 ISO			●	●	○
2		14E/I-2.0 ISO	21E/I-2.0 ISO	30E/I-2.0 ISO	40E/I-2.0 ISO	●	●	○
2.5		14E/I-2.5 ISO	21E/I-2.5 ISO			●	●	○
3			21E/I-3.0 ISO	30E/I-3.0 ISO	40E/I-3.0 ISO	●	●	○
3.5			21I-3.5 ISO	30E/I-3.5 ISO	40I-3.5 ISO	●	●	○
4				30E/I-4.0 ISO	40E/I-4.0 ISO	●	●	○
4.5				30I-4.5 ISO	40I-4.5 ISO	●	●	○
5					40E/I-5.0 ISO	●	●	○
5.5					40I-5.5 ISO	●	●	○
6					40E/I-6.0 ISO	●	●	○
H	6.3	7.5	12	16	20			
T	2.9	3.1	4.7	5.5	6.3			

- Turning inserts
- External turning
- Internal turning
- Grooving & parting
- Threading
- Milling
- Boring & drilling
- Tool holder
- Solid carbide end mills
- Solid carbide drill & taps
- Technical information

UN-60° American UN full profile

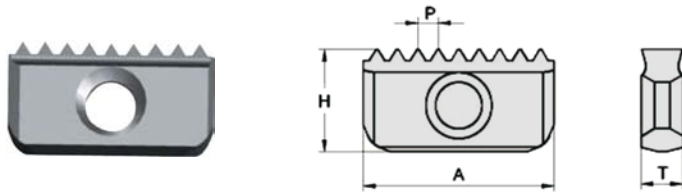

P	Steel	●	●	
M	Stainless Steel		●	
K	Cast Iron		●	
N	Non-ferrous Metal			●
S	Heat-resistant Alloy		●	

Pitch	Dimension					CVD	PVD	Uncoated
	12mm	14mm	21mm	30mm	40mm	TS7912	TS4125	TN9115
TPI						●	●	○
32	*12I-32 UN	14E/I-32 UN				●	●	○
28	*12I-28 UN	14E/I-28 UN				●	●	○
27		14I-27 UN				●	●	○
24	*12I-24 UN	14E/I-24 UN	21E/I-24 UN			●	●	○
20	*12I-20 UN	14E/I-20 UN	21E/I-20 UN	30E/I-20 UN		●	●	○
18	*12I-18 UN	14E/I-18 UN	21E/I-18 UN	30E/I-18 UN		●	●	○
16	*12I-16 UN	14E/I-16 UN	21E/I-16 UN	30E/I-16 UN	40E/I-16 UN	●	●	○
14		14E/I-14 UN	21E/I-14 UN	30E/I-14 UN	40E/I-14 UN	●	●	○
12		14E/I-12 UN	21E/I-12 UN	30E/I-12 UN	40E/I-12 UN	●	●	○
10			21E/I-10 UN	30E/I-10 UN	40E/I-10 UN	●	●	○
8			21I-8 UN	30E/I-8 UN	40E/I-8 UN	●	●	○
6				30E/I-6 UN	40E/I-6 UN	●	●	○
4.5					40I-4.5 UN	●	●	○
4					40I-4 UN	●	●	○
H	6.3	7.5	12	16	20			
T	2.9	3.1	4.7	5.5	6.3			

Turning inserts

External turning

Internal turning

Grooving & parting

Threading

Milling

Boring & drilling

Tool holder

Solid carbide end mills

Solid carbide drill & taps

Technical information

NPT-60° National pipe threading

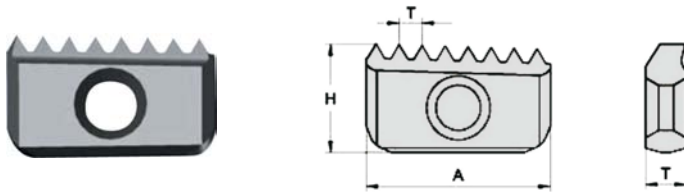

P	Steel	●	●	
M	Stainless Steel		●	
K	Cast Iron		●	
N	Non-ferrous Metal			●
S	Heat-resistant Alloy		●	

Pitch	Dimension					CVD	PVD	Uncoated
TPI	12mm	14mm	21mm	30mm	40mm	TS7912	TS4125	TN9115
18	*12-18 NPT	14-18 NPT				●	●	○
14		14-14 NPT	21-14 NPT			●	●	○
11.5			21-11.5 NPT	30-11.5 NPT	40-11.5 NPT	●	●	○
8				30-8 NPT	40-8 NPT	●	●	○
H	6.3	7.5	12	16	20			
T	2.9	3.1	4.7	5.5	6.3			

NPTF-American dry seal taper pipe threading

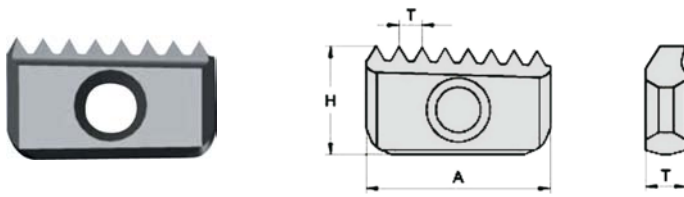

P	Steel	●	●	
M	Stainless Steel		●	
K	Cast Iron		●	
N	Non-ferrous Metal			●
S	Heat-resistant Alloy		●	

Pitch	Dimension					CVD	PVD	Uncoated
TPI	12mm	14mm	21mm	30mm	40mm	TS7912	TS4125	TN9115
18	*12-18 NPTF	14-18 NPTF				●	●	○
14		14-14 NPTF	21-14 NPTF			●	●	○
11.5			21-11.5 NPTF	30-11.5 NPTF	40-11.5 NPTF	●	●	○
8				30-8 NPTF	40-8 NPTF	●	●	○
H	6.3	7.5	12	16	20			
T	2.9	3.1	4.7	5.5	6.3			

Turning inserts

External turning

Internal turning

Grooving & parting

Threading

Milling

Boring & drilling

Tool holder

Solid carbide end mills

Solid carbide drill & taps

Technical information

Partial profile 60°

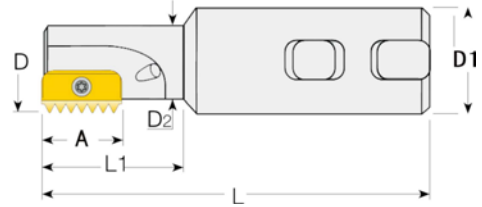

Part No.	Stock	Size						Screw	wrench
		A	D	D1	D2	L	L1		
SR0009H12	○	12	9.5	20	7.5	85	14	S12	K12
*SR0010H12	●	12	9.5	20	7.6	85	16	S12	K12
SR0012F14	●	14	12	20	8.9	75	20	S14	K14
SR0014H14	●	14	14.5	20	11.2	85	25	S14	K14
SR0017H14	●	14	17	20	13.4	85	30	S14	K14
**SR0018H21	●	21	18	20	14.4	85	30	S21	K21
SR0021H21	●	21	21	20	16.5	94	40	S21	K21
SR0029J30	●	30	29	25	22.4	110	50	S30	K30
SR0048M40	○	40	48	40	35	153	78	S40	K40

Partial profile 60°

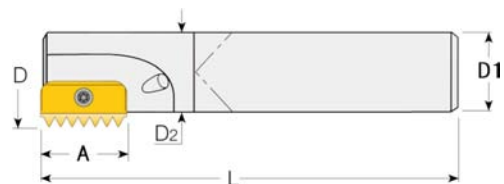

Part No.	Stock	Size				Screw	wrench
		A	D	D1	L		
SR0010K12C	○	12	9.9	8	125	S12	K12
SR0013H14C	●	14	13.2	10	110	S14	K12
SR0013J14C	●	14	13.2	10	150	S14	K14
SR0015K14C	●	14	15.2	12	175	S14	K14
SR0021K21C	●	21	21	16	130	S21	K21
SR0021M21C	●	21	21	16	200	S21	K21
SR0027S30C	○	30	27	20	270	S30	K30

● Stock ○ Available upon Order

Turning inserts

External turning

Internal turning

Grooving & parting

Threading

Milling

Boring & drilling

Tool holder

Solid carbide end mills

Solid carbide drill & taps

Technical information

Turning inserts

External turning

Internal turning

Grooving & parting

Threading

Milling

Boring & drilling

Tool holder

Solid carbide end mills

Solid carbide drill & taps

Technical information

ISO Metric Full Profile

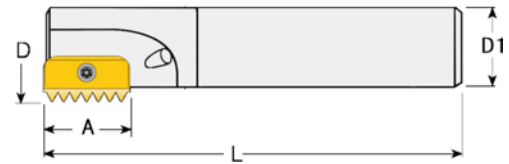

Part No.	Stock	Size				Screw	wrench
		A	D	D1	L		
SR0025K21	●	21	25	20	125	S21	K21
SR0031M30	●	30	31	25	150	S20	K20
SR0038M30	●	30	38	32	150	S30	K30
SR0048R40	●	40	48	40	210	S40	K40

ISO Metric Full Profile

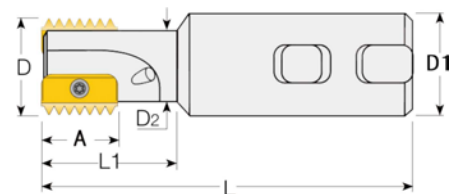

Part No.	Stock	Size						Z	Screw	wrench
		A	D	D1	D2	L	L1			
SR0020H14-2	○	14	20	20	16	93	41	2	S21	K21
SR0030J21-2	○	21	30	25	24	108	52	2	S20	K20
SR0040L30-2	○	30	40	32	30	130	70	2	S30	K30
SR0050M40-2	○	40	50	40	38	153	78	2	S40	K40

● Stock ○ Available upon Order

ISO Mrtric Full Profile

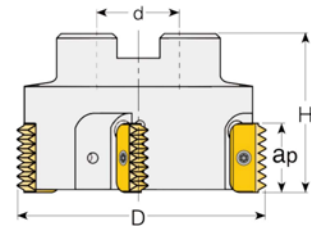

Part No.	Stock	Size				Z	Screw	wrench
		A	D	D1	L			
SR0063C21-5	○	21	63	22	50	5	S21	K21
SR0063C30-4	○	30	63	22	50	4	S30	K30
SR0080D30-4	○	30	80	27	55	4	S30	K30
SR0100D30-4	○	30	100	32	60	4	S30	K30
SR0080D40-4	○	40	80	27	65	4	S40	K40
SR0100E40-4	○	40	100	32	70	4	S40	K40

Processing parameter list of thread milling cutter

Material	Carbon steel S50C, Q235		Alloy steel 25-35HRC 4Cr5MoSiV1, Cr12		Stainless steel SUS304, 316, 0Cr19Ni9		Cast iron HT250, QT450		Aluminium alloy	
	Vc=m/min	ap=mm	Vc=m/min	ap=mm	Vc=m/min	ap=mm	Vc=m/min	ap=mm	Vc=m/min	ap=mm
External thread	100-250	0.05-0.15	90-150	0.05-0.15	100-160	0.05-0.15	70-150	0.05-0.15	160-300	0.05-0.15
Internal thread										

● Stock ○ Available upon Order

Turning inserts

External turning

Internal turning

Grooving & parting

Threading

Milling

Boring & drilling

Tool holder

Solid carbide
end mills

Solid carbide
drill & taps

Technical
information

Milling tools



Recommended Cutting Data

Workpiece Materials	Materials Hardness	Grade	Recommended Cutting Speed	mm/tooth			
				Light Cutting	Medium Cutting	Heavy Cutting	
			Vc (m/min)				
P	Low Carbon Steel	≤HB180	NS4115 NS4125 NP115T	180 (150-220)	0.08 (0.05-0.15)	0.1 (0.08-0.15)	0.12 (0.08-0.2)
					0.08 (0.05-0.15)	0.12 (0.08-0.18)	0.15 (0.1-0.25)
					0.15 (0.1-0.25)	0.2 (0.15-0.3)	0.25 (0.2-0.35)
	Carbon Steel, Alloy Steel	HB180-350	NS4115 NS4125	160 (140-200)	0.18 (0.1-0.25)	0.25 (0.1-0.35)	0.3 (0.1-0.45)
					0.08 (0.05-0.15)	0.1 (0.08-0.15)	0.12 (0.08-0.2)
					0.08 (0.05-0.15)	0.12 (0.08-0.18)	0.15 (0.1-0.25)
	Per-hardened Steel	HRC35-45	NS4115 NS4125	120 (100-160)	0.15 (0.1-0.25)	0.2 (0.15-0.3)	0.25 (0.2-0.35)
					0.18 (0.1-0.25)	0.25 (0.1-0.35)	0.3 (0.1-0.45)
					0.08 (0.05-0.15)	0.1 (0.08-0.15)	0.12 (0.08-0.2)
M	Stainless Steel (Ferrite, Martensite)	≤HB270	NS4115 NS4125	140 (120-180)	0.08 (0.05-0.15)	0.1 (0.08-0.15)	0.12 (0.08-0.2)
					0.08 (0.05-0.15)	0.12 (0.08-0.18)	0.15 (0.1-0.25)
					0.15 (0.1-0.25)	0.2 (0.15-0.3)	0.25 (0.2-0.35)
	Stainless Steel (Austenite, Diphasic)	≤HB270	NS4115 NS4125	120 (100-160)	0.18 (0.1-0.25)	0.25 (0.1-0.35)	0.3 (0.1-0.45)
					0.08 (0.05-0.15)	0.1 (0.08-0.15)	0.12 (0.08-0.2)
					0.08 (0.05-0.15)	0.12 (0.08-0.18)	0.15 (0.1-0.25)
K	Grey Cast Iron	≤HB280	NS4115 NS4125	180 (150-220)	0.15 (0.1-0.25)	0.2 (0.15-0.3)	0.25 (0.2-0.35)
					0.18 (0.1-0.25)	0.25 (0.1-0.35)	0.3 (0.1-0.45)
					0.08 (0.05-0.15)	0.1 (0.08-0.15)	0.12 (0.08-0.2)
	Nodular Cast Iron Vermicular Cast Iron	≤HB350	NS4115 NS4125	120 (100-180)	0.08 (0.05-0.15)	0.12 (0.08-0.18)	0.15 (0.1-0.25)
					0.15 (0.1-0.25)	0.2 (0.15-0.3)	0.25 (0.2-0.35)
					0.18 (0.1-0.25)	0.25 (0.1-0.35)	0.3 (0.1-0.45)
S	Heat-resistant Alloy and Titanium Alloy	HRC25-35	NS4115 NS4125	40 (30-60)	0.08 (0.05-0.15)	0.12 (0.08-0.18)	0.15 (0.1-0.25)
					0.1 (0.05-0.15)	0.12 (0.08-0.2)	0.15 (0.1-0.25)
					0.1 (0.05-0.15)	0.12 (0.08-0.2)	0.15 (0.1-0.25)
N	Aluminum Alloy	HB60-210	NN9115	500 (200-900)	0.15 (0.1-0.25)	0.2 (0.15-0.3)	0.25 (0.2-0.35)

- ★ Tool RPM (min⁻¹) = (1000 X Cutting Speed) / (3.14 X Diameter of Cutter)
- ★ Workpiece Feed (mm/min) = Feed Per Tooth X Number Of Tooth X Tool RPM

Turning inserts

External turning

Internal turning

Grooving & parting

Threading

Milling

Boring & drilling

Tool holder

Solid carbide end mills

Solid carbide drill & taps

Technical information

Turning inserts

External turning

Internal turning

Grooving & parting

Threading

Milling

Boring & drilling

Tool holder

Solid carbide end mills

Solid carbide drill & taps

Technical information

Milling cutter

Two-side spiral blade 90 degree shoulder facing end mill— it is suitable for all kinds of plane, ladder, slotting machining, is in best efficiency and precision.

Main Characters

1. The inserts are in two-side and four-blade design, and they are thick and strong for deep milling process.
2. The design of swallow tail oblique trough, combined with insert repairing blade, could satisfy milling process for high finishing surface requirement.
3. Cutters adopt to orthogonal screw clamp to ensure higher clamp rigidity and safety.
4. Cutters' thick teeth design, combined with the design of low cutting resistance is a high process efficiency.
5. The model 06 thickness design could ensure the most cutting depth up to more than 10mm.
6. The diameter of cutter is from 40mm to 250mm, and it could cover the whole plane.



Before the big Angle design sharp edge is strong



Double-sided four edges

Case Study 1



Material Science	304 Stainless steel
Processing method	Slotting machining
Insert	ANMX080408-PDR-NS4125
Cutter head	BAN08-1616T2-160



The cutting parameters
 $V_c=110\text{m/min}$
 $f_z=0.8\text{mm/t}$
 $a_p=1.2\text{mm}$
 $a_e=16\text{mm}$

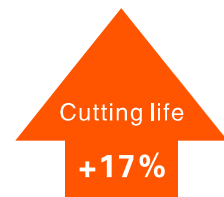

Case Study 2



Material Science	45# (HRC22)
Processing method	Face milling, dry cutting
Insert	ANMX160608-PDR-NS4125
Cutter head	BAN16D063T5-22

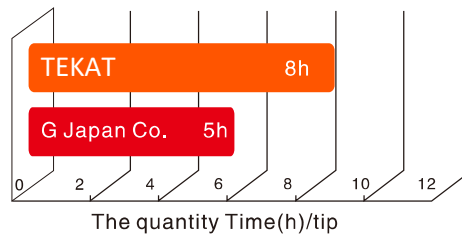

The cutting parameters
 $V_c=180\text{m/min}$
 $f=1.34\text{mm}$
 $a_p=1.5\text{mm}$
 $a_e=40\text{mm}$

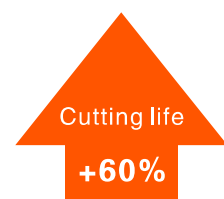

Two face spiral blade 4S degree face milling cutter

It is suitable for all kinds of plane process, and it is used for many places. And we provide goods in high quality at good price. It can clamp two kind of inserts to the same retaining nest. The inserts are the two-side square ones with 8 cutting edges and the two-side octagonal ones with 16 cutting edges

Main characters

- Orthogonal screw clamp could ensure better clamp rigidity and safety.
- Thick tooth design makes much higher efficiency.
- Square inserts could cut 5mm in depth at most, and the orthogonal ones 3mm.
- One cutter with two kinds of inserts is suitable for roughing, semi-finishing and finishing.
- It is very economical, with 8 cutting edges and 16 cutting edges.
- It has repairing light blade inserts, and could lead to high quality.
- The diameter of cutter is from 40mm to 315mm, and it could cover the whole plane.



Case Study 1

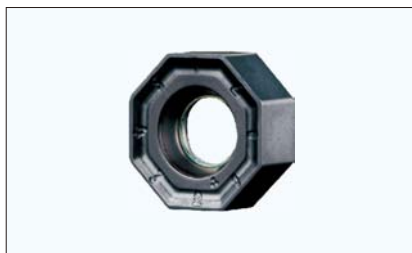

Material Science	HT300(HB230)
Processing method	Face milling, dry cutting
Insert	ONMU1205ANEN-NM-NS4125
Cutter head	SONFM45D080T06-27

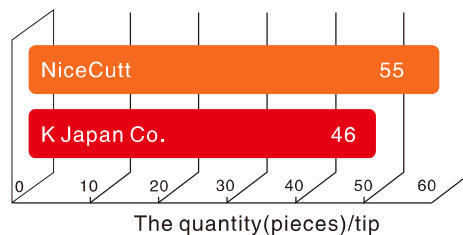

The cutting parameters
 $V_c=200\text{m/min}$
 $f_z=0.15\text{mm/t}$
 $a_p=3.5\text{mm}$
 $a_e=50\text{mm}$

Cutting life
+20%

Case Study 2



Material Science	45# (HRC22)
Processing method	Face milling, dry cutting
Insert	SNMU1205ANEN-NM-NS4125
Cutter head	SONFM45D080T06-27

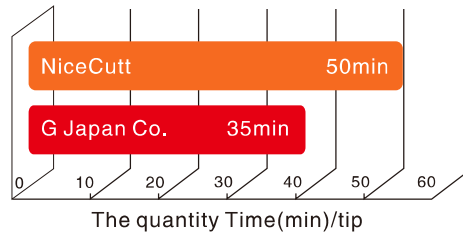

The cutting parameters
 $V_c=250\text{m/min}$
 $f_z=0.2\text{mm/t}$
 $a_p=2\text{mm}$
 $a_e=25\text{mm}$

Cutting life
+40%

Turning inserts

External turning

Internal turning

Grooving & parting

Threading

Milling

Boring & drilling

Tool holder

Solid carbide end mills

Solid carbide drill & taps

Technical information

ODKT Insert

- The main angle is 43 DEG collocation type cutter body angle, ensuring quick cutting;
- The collocation excellent high universal brands: NS4115, NS4125; NN9115
- Is the most suitable for steel (P), stainless steel (M), iron (K), Aluminum Alloy (N) high economic face milling.

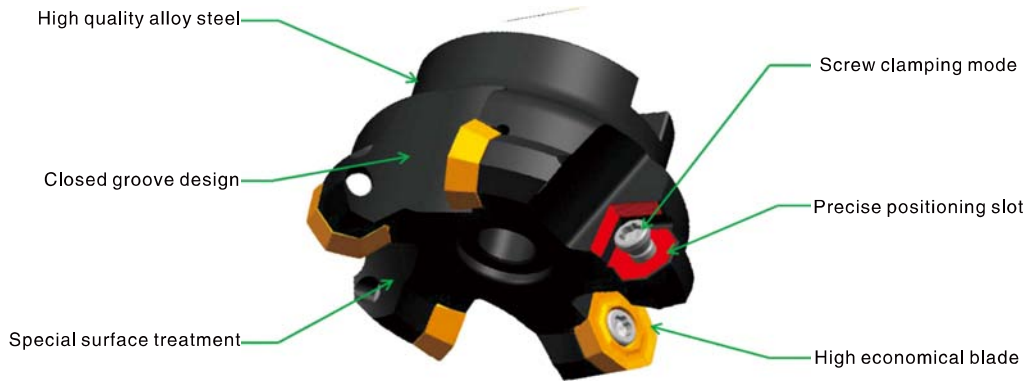

Case Study 1



Material Science	High temperature alloy steel (1.4839)
Processing method	Plane milling, finish machining
Insert	ODKT060508-NM-NS4125
Cutter head	FM45-D063T05-22-OD06

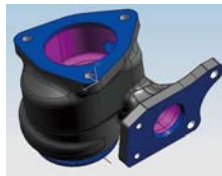

The cutting parameters
 $V_c=100\text{m/min}$
 $f_z=0.2\text{mm/t}$
 $a_p=1.5\text{mm}$
 $D=63\text{mm}$

Cutting life
+25%

Case Study 2



Material Science	45# (HRC22)
Processing method	Face milling, dry cutting
Insert	ONMU1205ANEN-NM-NS4125
Cutter head	SONFM45D080T06-27

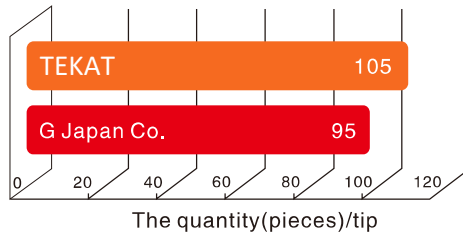

The cutting parameters
 $V_c=130\text{m/min}$
 $f_z=0.2\text{mm/t}$
 $a_p=0.3\text{mm}$
 $a_e=80\text{mm}$

Cutting life
+20%

TMR Milling Cutter

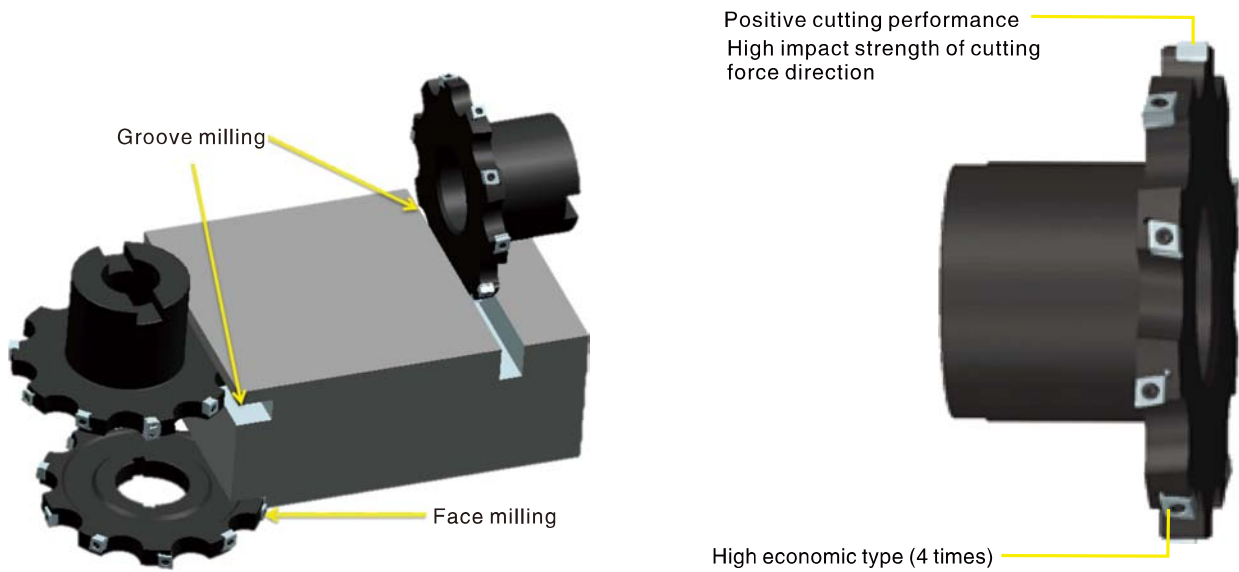

Case Study 1



Material Science	HT250 (HB180-230)
Processing method	Milling back
Insert	CNEU070508-NM-NS4125
Cutter head	TMR-080.H10.06T27-CN07

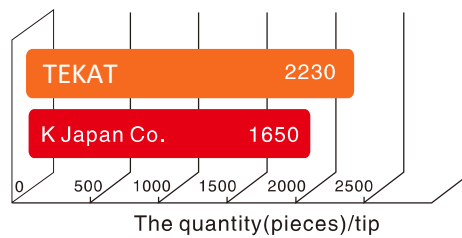

The cutting parameters
 $V_c=220\text{m/min}$
 $f_z=0.2\text{mm/t}$
 $a_p=3.5\text{mm}$
 $D=80\text{mm}$

Cutting life
+35%

Case Study 2



Material Science	HT250
Processing method	Milling back
Insert	CNEU070508-NM-NS4125
Cutter head	TMR-125.H10.10T32-CN07

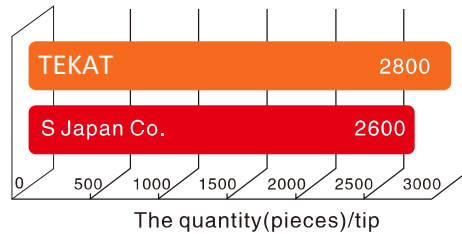

The cutting parameters
 $V_c=220\text{m/min}$
 $f_z=0.2\text{mm/t}$
 $a_p=15\text{mm}$
 $a_e=125\text{mm}$

Cutting life
+6%

Turning inserts

External turning

Internal turning

Grooving & parting

Threading

Milling

Boring & drilling

Tool holder

Solid carbide end mills

Solid carbide drill & taps

Technical information

Turning inserts

External turning

Internal turning

Grooving & parting

Threading

Milling

Boring & drilling

Tool holder

Solid carbide end mills

Solid carbide drill & taps

Technical information

APMT/APGT**



P170

ANMX



P170

SEEN/SEEX



P171

SPKN/SPER



P171

SPEN



P171

SEETPL**



P172

SEETPM**



P172

SEETPK**



P172

SEETPH**



P172

SEETPG**



P172

SEETPL**



P172

SEETPW**



P172

SNEUNL**



P173

SNEUNM**



P173

SNEUNW**



P173

SNMU



P173

ONMU



P173

ODKTNL**



P174

ODKTNM**



P174

ODKTNH**



P174

TPKN



P174

TPER



P174

RPET/RDETNL/NM**



P175~P176

RPEW/RDEW



P175~P176

<p>RCET**NE</p>  <p>P123</p>	<p>RDET**MH</p>  <p>P123</p>	<p>UDET</p>  <p>P124</p>	<p>UDMT</p>  <p>P123</p>
<p>CNEU</p>  <p>P177</p>	<p>HNMX/SNEX</p>  <p>P178</p>	<p>SNEX</p>  <p>P178</p>	<p>QOHX</p>  <p>P179</p>
<p>QPHT</p>  <p>P179</p>	<p>MFT</p>  <p>P180</p>	<p>T2139-P32**</p>  <p>P181</p>	<p>BAP/RP</p>  <p>P182</p>
<p>BFR</p>  <p>P183</p>	<p>BAP</p>  <p>P184~P185</p>	<p>BRP</p>  <p>P186~P187</p>	<p>BRD</p>  <p>P188~P189</p>
<p>DX45</p>  <p>P190</p>	<p>BTC</p>  <p>P190</p>	<p>TP</p>  <p>P191</p>	<p>BSC</p>  <p>P191</p>
<p>AJU</p>  <p>P192</p>	<p>ATS</p>  <p>P192</p>	<p>BUD</p>  <p>P193</p>	<p>BAP</p>  <p>P194</p>

Turning inserts

External turning

Internal turning

Grooving & parting

Threading

Milling

Boring & drilling

Tool holder

Solid carbide end mills

Solid carbide drill & taps

Technical information

Turning inserts

External turning

Internal turning

Grooving & parting

Threading

Milling

Boring & drilling

Tool holder

Solid carbide end mills

Solid carbide drill & taps

Technical information

BRP/BRD



P194~P195

BAN



P196

BAN



P196

SONFM



P197

TFM55°



P197

SE12 45°



P198

BSE45°



P198

SE13 45°



P199

FM



P199

BM90°



P200

BM90°



P200

BT



P201

HMC



P201

HMC



P202

TMR



P202

SMR



P203

STF



P203

STF



P203

BBMS



P204

APMT





Shoulder Milling Inserts

● continuous

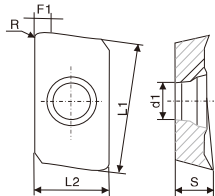
◐ light Interruption

⊕ Interruption



Shape	Ordering Code	Dimensions(mm)						Coated-PVD		Uncoated	Cermet
		L1	L2	S	F1	d1	R	TS7912	TS4125	TN9115	TP115T
	APMT1135PDER-NL	10.83	6.16	3.50	1.92	2.80	0.80	●	●		
	APMT1604PDER-NL	16.26	9.26	4.76	2.00	4.60	0.80	●	●		
	APMT1135PDER-NM	10.83	6.16	3.50	1.92	2.80	0.80	●	●		○
	APMT1604PDER-NM	16.26	9.26	4.76	2.00	4.60	0.80	●	●		○
	APMT1135PDER-NR	10.83	6.16	3.50	1.92	2.80	0.80	●	●		○
	APMT1604PDER-NR	16.26	9.26	4.76	2.20	4.40	0.80	●	●		○
	APGT1135PDFR-AL	10.83	6.16	3.50	1.92	2.80	0.80			●	
	APGT1604PDFR-AL	16.26	9.26	4.76	2.20	4.40	0.80			●	

ANMX

Shoulder Milling Inserts

● continuous

◐ light Interruption

⊕ Interruption

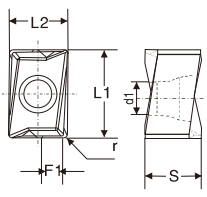

Shape	Ordering Code	Dimensions(mm)						Coated-PVD		Uncoated	Cermet
		L1	L2	S	F1	d1	R	TS7912	TS4125	TN9115	TP115T
	ANMX080404-PDR	8.60	6.60	5.20	2.50	3.50	0.40	●	○		
	ANMX080408-PDR	8.60	6.60	5.20	2.50	3.50	0.80	●	●		
	ANMX130508-PDR	13.70	10.00	8.90	3.40	4.40	0.80	●	●		
	ANMX130512-PDR	13.70	10.00	8.90	3.40	4.40	1.20	●	○		
	ANMX160608-PDR	16.70	11.20	10.40	4.70	5.40	0.80	●	●		
	ANMX160612-PDR	16.70	11.20	10.40	4.70	5.40	1.20	●	○		

● Stock ○ Available upon Order

Turning inserts

External turning

Internal turning

Grooving & parting

Threading

Milling

Boring & drilling

Tool holder

Solid carbide end mills

Solid carbide drill & taps

Technical information

SEEN SPKN SPEN

Face Milling Inserts

● continuous ◐ light Interruption ⊕ Interruption

	P	Steel	●	◐		●				
	M	Stainless Steel	●	◐						
	K	Cast Iron	●	◐	●					
	N	Non-ferrous Metal								
	S	Heat-resistant Alloy, TiAlloy	●	◐						
	H	High Hardness Materials								
Shape	Ordering Code	Dimensions(mm)					Coated-PVD		Uncoated	Cermet
		L	D	S	θ	bs	TS7912	TS4125	TN9115	TP115T
	SEEN1203AFTN	12.70	12.70	3.18	45°	2.30	●	○	○	○
	SEEN1204AFTN	12.70	12.70	4.76	45°	2.40	●	○	○	○
	SEEN1504AFTN	15.88	15.88	4.76	45°	2.40	●	○	○	○

Face Milling Inserts

	Dimensions(mm)					Coated-PVD		Uncoated	Cermet	
	L	D	S	θ	R	TS7912	TS4125	TN9115	TP115T	
	SPKN1203EDR	12.70	12.70	3.18	15°	1.40	●	○	○	○
	SPKN1203EDL	12.70	12.70	3.18	15°	1.40	●	○	○	○
	SPKN1504EDR	15.88	15.88	4.76	15°	1.40	●	○	○	○
	SPKN1504EDL	15.88	15.88	4.76	15°	1.40	●	○	○	○

Face Milling Inserts

	Dimensions(mm)						Coated-PVD		Uncoated	Cermet	
	L1	L2	D	S	θ	bs	TS7912	TS4125	TN9115	TP115T	
	SPEN1504EDR-W	15.88	18.20	15.88	4.76	15°	10.20	●	○	○	○
	SPEN1504EDL-W	15.88	18.20	15.88	4.76	15°	10.20	●	○	○	○

● Stock ○ Available upon Order

Turning inserts

External turning

Internal turning

Grooving & parting

Threading

Milling

Boring & drilling

Tool holder

Solid carbide end mills

Solid carbide drill & taps

Technical information

SEET

Face Milling Inserts

● continuous

◐ Light Interrupt on

⊕ Interrupt on

Shape	Ordering Code	Dimensions(mm)						Coated-PVD		Uncoated	Cermet
		L	D	S	d1	θ	bs	TS7912	TS4125	TN9115	TP115T
	SEET1204AFEN-NL*	12.70	12.70	4.76	5.50	45°	2.50	●	◐	◐	◐
	SEET1204AFEN-NL	12.70	12.70	4.76	5.50	45°	2.50			●	
	SEET13T3AGEN-NL	13.40	13.40	3.97	4.40	45°	1.70	●	●		◐
	SEET13T3AGEN-NM	13.40	13.40	3.97	4.40	45°	1.20	●	●		
	SEET13T3AGSN-NK	13.40	13.40	3.97	4.40	45°	1.30	●	●		
	SEET13T3AGSN-NH	13.40	13.40	3.97	4.40	45°	1.30	●	●		
	SEET13T3AGSN-NG	13.40	13.40	3.97	4.40	45°	1.30	●	●		
	SEET13T3AGFN-AL	13.40	13.40	3.97	4.40	45°	2.20			●	
	SEET13T3AGEN-NW	7.69	13.40	3.97	4.40	45°	2.20	●	●		

● Stock ◐ Available upon Order

Turning inserts

External turning

Internal turning

Grooving & parting

Threading

Milling

Boring & drilling

Tool holder

Solid carbide end mills

Solid carbide drill & taps

Technical information

SNEU

Face Milling Inserts

● continuous

◐ Light Interrupt on

⊕ Interrupt on

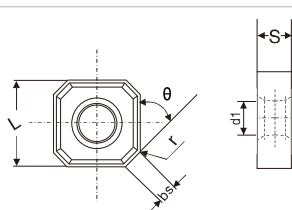

P	Steel	●	◐		
M	Stainless Steel	●	◐		
K	Cast Iron	●	◐		
N	Non-ferrous Metal			●	
S	Heat-resistant Alloy, TiAlloy	●	◐		
H	High Hardness Materials				

Shape	Ordering Code	Dimensions(mm)						Coated-PVD		Uncoated	Cermet
		L	S	d1	θ	bs	R	TS7912	TS4125	TN9115	TP115T
	SNEU1205ANEN-NL	12.70	6.35	6.00	45°	2.20	0.80	●	●		
	SNEU1205ANEN-NM	12.70	6.35	6.00	45°	2.20	0.80	●	●		
	SNEU1205ANFN-NL	12.70	6.35	6.00	45°	2.20	0.80			●	
	SNEU1205ANEN-NW	12.70	6.35	6.00	45°	5.60	0.80	●	●		
	SNMU1205ANER-NM	12.90	5.50	6.00	45°	3.00	0.50	●	●		

ONMU

Face Milling Inserts

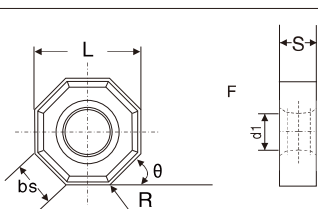

Shape	Ordering Code	Dimensions(mm)						Coated-PVD		Uncoated	Cermet
		L	S	d1	θ	bs	R	TS7912	TS4125	TN9115	TP115T
	ONMU1205ANEN-NM	12.90	5.50	6.00	45°	5.00	0.50	●	●		

● Stock ○ Available upon Order

ODKT TPKN





Face Milling Inserts

● continuous

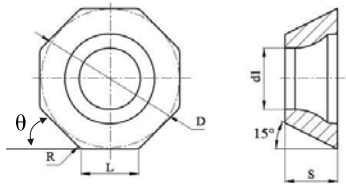
◐ Light Interrupt on



⊕ Interrupt on

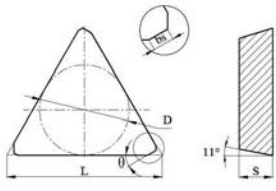

Shape	Ordering Code	Dimensions(mm)						Coated-PVD		Uncoated	Cermet
		L	D	S	d1	θ	R	TS7912	TS4125	TN9115	TP115T
	ODKT060508-NL	6.50	15.88	5.56	5.56	45°	0.80	●	●		
	ODKT060508-NM	6.50	15.88	5.56	5.56	45°	0.80	●	●		
	ODKT060508-NR	6.50	15.88	5.56	5.56	45°	0.80	●	●		
	ODKT060508-NL	6.50	15.88	5.56	5.56	45°	0.80			●	

Face Milling Inserts



Shape	Ordering Code	Dimensions(mm)					Coated-PVD		Uncoated	Cermet
		L	D	S	θ	bs	TS7912	TS4125	TN9115	TP115T
	TPKN1603PDR	16.50	9.53	3.18	30°	1.30			●	
	TPKN2204PDR	22.00	12.70	4.76	30°	1.40			●	
	TPER1603PDTR-NR	16.50	9.53	3.18	30°	1.30			●	

● Stock ○ Available upon Order

Turning inserts

External turning

Internal turning

Grooving & parting

Threading

Milling

Boring & drilling

Tool holder

Solid carbide end mills

Solid carbide drill & taps

Technical information

RPET/RPEW/RCET

Profiling Milling Inserts

● continuous

◐ Light Interrupt on

⊕ Interrupt on

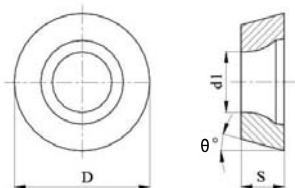

P	Steel	●	◐		
M	Stainless Steel	●	◐		
K	Cast Iron	●	◐		
N	Non-ferrous Metal				
S	Heat-resistant Alloy, TiAlloy	●	◐		
H	High Hardness Materials				

Shape	Ordering Code	Dimensions(mm)				Coated-PVD		Uncoated	Cermet
		D	S	d1	θ	TS7912	TS4125	TN9115	TP115T
	RPET1003M0-NL	10.00	3.18	4.40	11°	●	●		
	RPET1204M0-NL	12.00	4.76	4.40	11°	●	●		
	RPET08T2M0-NM	8.00	2.78	2.94	11°	●	○		
	RPET1003M0T-NM	10.00	3.18	4.40	11°	●	●		
	RPMT1003M0T-NM	10.00	3.18	4.40	11°	●	●		
	RPET1204M0-NM	12.00	4.76	4.40	11°	●	●		
	RPMT1204M0-NM	12.00	4.76	4.40	11°	●	●		
	RPET1204M0T-NM	12.00	4.76	4.40	11°	●	●		
	RPET1606M0T-MM	16.00	6.35	5.50	11°	●	●		
	RPEW08T2M0	8.00	2.78	2.94	11°	●	○		
	RPEW1003M0	10.00	3.18	4.40	11°	●	●		
	RPEW10T3M0	10.00	3.18	4.40	11°		●		
	RPMW10T3M0	10.00	3.18	4.40	11°	●	●		
	RPEW1204M0T	12.00	4.76	4.40	11°	●	●		
	RPMW1204M0T	12.00	4.76	4.40	11°	●	●		
	RCET10T3M0-NE	10.00	3.97	4.40	7°	●	●		
	RCET1204M0-NE	12.00	4.76	4.00	7°	●	●		

● Stock ○ Available upon Order

- Turning inserts
- External turning
- Internal turning
- Grooving & parting
- Threading
- Milling
- Boring & drilling
- Tool holder
- Solid carbide end mills
- Solid carbide drill & taps
- Technical information

RDET/RDEW/RDMW

Profiling Milling Inserts

● continuous

◐ Light Interrupt on

⊕ Interrupt on

Shape	Ordering Code	Dimensions(mm)				Coated-PVD		Uncoated	Cermet
		D	S	d1	θ	TS7912	TS4125	TN9115	TP115T
	RDET0803M0-NL	8.00	3.18	2.94	15°	●	○		
	RDET10T3M0-NL	10.00	3.97	4.40	15°	●	●		
	RDET1204M0-NL	12.00	4.76	4.40	15°	●	●		
	RDET1604M0-NL	16.00	4.76	5.50	15°	●	●		
	RDET0802M0-NM*	8.00	2.38	2.94	15°	●			
	RDET0803M0-NM	8.00	3.18	2.94	15°	●	○		
	RDET10T3M0-NM	10.00	3.97	4.40	15°	●	●		
	RDMT10T3M0-NM	10.00	3.97	4.40	15°	●	●		
	RDET1204M0-NM	12.00	4.76	4.40	15°	●	●		
	RDMT1204M0-NM	12.00	4.76	4.40	15°	●	●		
	RDET1204M0-NH	12.00	4.76	4.40	15°	●			
	RDMW1605M0T-NH	16.00	5.56	5.50	15°				
	RDEW0501M0	5.00	1.51	2.20	15°	●	○		
	RDEW0702M0T	7.00	2.38	2.80	15°	●	○		
	RDEW0803M0T	8.00	3.18	2.94	15°	●	○		
	RDEW10T3M0T	10.00	3.97	4.40	15°	●	●		
	RDEW1204M0T	12.00	4.76	4.40	15°	●	●		
	RDEW1604M0T	16.00	4.76	5.50	15°	●	●		

● Stock ○ Available upon Order

Turning inserts

External turning

Internal turning

Grooving & parting

Threading

Milling

Boring & drilling

Tool holder

Solid carbide end mills

Solid carbide drill & taps

Technical information

UDET/UDMT SDMT CNEU

Face Milling Inserts

● continuous

◐ Light Interrupt on

⊕ Interrupt on

Shape	Ordering Code	Dimensions(mm)				Coated-PVD		Uncoated	Cermet
		D	S	d1	θ	TS7912	TS4125	TN9115	TP115T
	UDET080308-NM	6.80	3.18	2.94	15°	●	●		
	UDET12T312-NM	9.60	3.97	4.40	15°	●	●		
	UDMT080308T-NH	6.80	3.18	2.94	15°	●	●		
	UDMT12T312T-NH	9.60	3.97	4.40	15°	●	●		

Face Milling Inserts

● continuous

◐ Light Interrupt on

⊕ Interrupt on

Shape	Ordering Code	Dimensions(mm)					Coated-PVD		Uncoated	Cermet
		D	S	d1	θ	R	TS7912	TS4125	TN9115	TP115T
	CNEU070508-NM	7.60	5.00	3.40	80°	0.80	●	●		

● Stock ○ Available upon Order

Turning inserts

External turning

Internal turning

Grooving & parting

Threading

Milling

Boring & drilling

Tool holder

Solid carbide end mills

Solid carbide drill & taps

Technical information

HNMX SNEX

Face Milling Inserts

● continuous

◐ Light Interrupt on

⊕ Interrupt on

Shape	Ordering Code	Dimensions(mm)						Coated-CVD		Coated-PVD	
		L	D	S	d1	θ	R	TS7912	TS4125	TN9115	TP115T
	HNMX050410-NM	7.10	12.70	5.00	5.00	55°	1.00	●	○	○	●

SNEX

Shoulder Milling Inserts

Shape	Ordering Code	Dimensions(mm)				Coated-CVD		Coated-PVD	
		D	L	S	d1	TS7912	TS4125	TN9115	TP115T
	SNEX1202-GM	12.70	12.70	2.30	5.00	●	●	○	●
	SNEX1203-GM	12.70	12.70	3.00	5.00	●	●	○	●
	SNEX12T3-GM	12.70	12.70	3.50	5.00	●	●	○	●
	SNEX1204-GM	12.70	12.70	4.00	5.00	●	●	○	●
	SNEX12T4-GM	12.70	12.70	4.50	5.00	●	●	○	●

● Stock ○ Available upon Order

Turning inserts

External turning

Internal turning

Grooving & parting

Threading

Milling

Boring & drilling

Tool holder

Solid carbide end mills

Solid carbide drill & taps

Technical information

QOHX

Shoulder Milling Inserts

● continuous

◐ light Interruption

⊕ Interruption

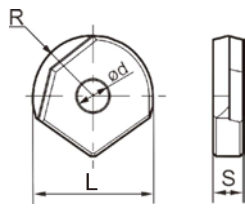

P	Steel				●
M	Stainless Steel				◐
K	Cast Iron				●
N	Non-ferrous Metal				
S	Heat-resistant Alloy, TiAlloy				◐
H	High Hardness Materials				

Shape	Ordering Code	Dimensions(mm)				Coated-CVD		Coated-PVD	
		L	S	d	R	TS7912	TS4125	TN9115	TP115T
	P3201-D10	10.00	3.00	4.00	5.00	●			●
	P3201-D12	12.00	3.00	4.00	6.00	●			●
	P3201-D16	16.00	4.00	5.00	8.00	●			●
	P3201-D20	20.00	5.00	5.00	10.00	●			●
	P3201-D25	25.00	6.00	6.00	12.50	●			●
	P3201-D32	32.00	7.00	8.00	16.00	●			●

QPHT

Face Milling Inserts

● continuous

◐ light Interruption

⊕ Interruption

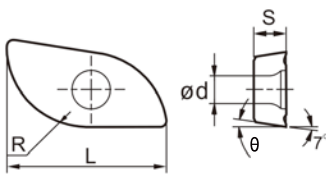

P	Steel					●
M	Stainless Steel					◐
K	Cast Iron					●
N	Non-ferrous Metal					
S	Heat-resistant Alloy, TiAlloy					◐
H	High Hardness Materials					

Shape	Ordering Code	Dimensions(mm)					Coated-CVD		Coated-PVD	
		L	R	S	d1	θ	TS7912	TS4125	TN9115	TP115T
	ZCEW100CE	20.00	10.00	3.97	4.00	11°	●	●		●
	ZCEW100SE	20.00	10.00	3.97	4.00	11°	●	●		●
	ZCEW125CE	25.00	12.50	4.76	4.70	11°	●	●		●
	ZCEW125SE	25.00	12.50	4.76	4.70	11°	●	●		●
	ZCEW150CE	30.00	15.00	6.35	5.80	11°	●	●		●
	ZCEW150SE	30.00	15.00	6.35	5.80	11°	●	●		●
	ZCEW160CE	32.00	16.00	6.35	5.80	11°	●	●		●
	ZCEW160SE	32.00	16.00	6.35	5.80	11°	●	●		●

● Stock ○ Available upon Order

MFT Anti vibration milling tool bar series

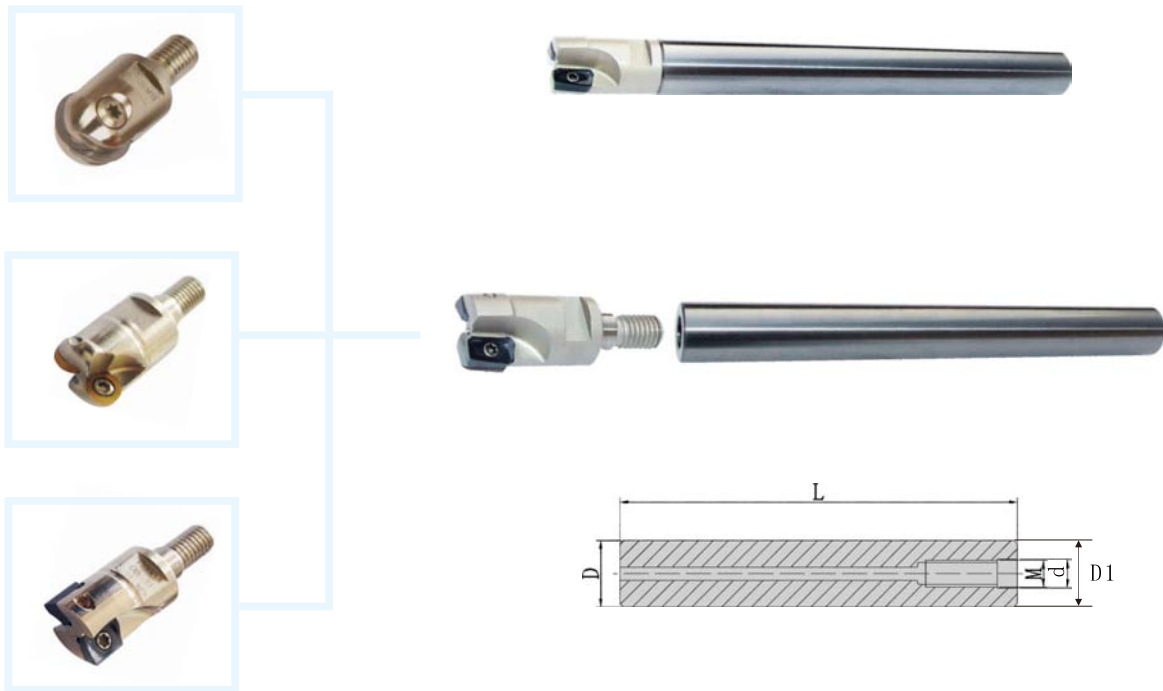

Ordering Code	Stock	Dimensions(mm)				
		D	D1	L	M	d
MFT10-10-100-M5	●	10	10	100	M5	5.5
MFT10-10-150-M5	●	10	10	150	M5	5.5
MFT12-12-100-M6	●	12	12	100	M6	6.5
MFT12-12-150-M6	●	12	12	150	M6	6.5
MFT12-12-200-M6	●	12	12	200	M6	6.5
MFT16-16-100-M8	●	16	16	100	M8	8.5
MFT16-16-150-M8	●	16	16	150	M8	8.5
MFT16-16-200-M8	●	16	16	200	M8	8.5
MFT20-20-150-M10	●	20	20	100	M10	10.5
MFT20-20-200-M10	●	20	20	150	M10	10.5
MFT20-20-250-M10	●	20	20	200	M10	10.5
MFT25-25-150-M12	●	25	25	150	M12	12.5
MFT25-25-200-M12	●	25	25	200	M12	12.5
MFT25-25-250-M12	●	25	25	250	M12	12.5
MFT25-25-300-M12	●	25	25	300	M12	12.5
MFT32-32-150-M16	●	32	32	150	M16	17
MFT32-32-200-M16	●	32	32	200	M16	17
MFT32-32-250-M16	●	32	32	250	M16	17
MFT32-32-300-M16	●	32	32	300	M16	17
MFT32-32-400-M16	●	32	32	400	M16	17

● Stock ○ Available upon Order

Turning inserts

External turning

Internal turning

Grooving & parting

Threading

Milling

Boring & drilling

Tool holder

Solid carbide end mills

Solid carbide drill & taps

Technical information

BF Ball End,finish milling cutters(thread)

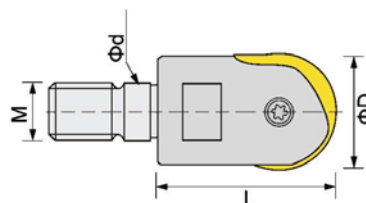

Ordering Code	Stock	Dimensions(mm)				Insert	Screw	Wrench
		D	d	L	M			
WGR10-M05	●	10	5.5	20	M5			
WGR12-M06	●	12	6.5	22	M6	P3202-D10	P32-M4	T-15
WGR16-M08	●	16	8.5	28	M8	P3202-D12		
WGR20-M10	●	20	10.5	30	M10	P3202-D16	P32-M5	T-320
WGR25-M12	●	25	12.5	40	M12	P3202-D20		
WGR32-M16	●	32	17.0	43	M16	P3202-D25	P32-M6	T-30
						P3202-D32	P32-M8	

BF Ball End,finish milling cutters

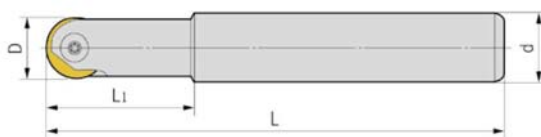





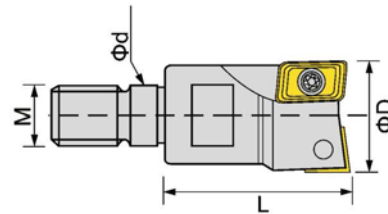

Ordering Code	Stock	Dimensions(mm)				Insert	Screw	Wrench
		D	d	L	L1			
T2139-5R-120-C10	●	10	10	130	30			
T2139-5R-150-C16	●	10	10	160	35			
T2139-6R-130-C12	●	12	12	130	30	P3202-D10	P32-M4	T-15
T2139-6R-150-C12	●	12	12	160	30			
T2139-8R-130-C16	●	16	16	120	30	P3202-D12	P32-M5	T20
T2139-8R-150-C16	●	16	16	160	30			
T2139-8R-200-C16	●	16	16	200	45	P3202-D16	P32-M5	T20
T2139-10R-150-C20	●	20	20	160	30			
T2139-10R-200-C20	●	20	20	200	35	P3202-D20	P32-M6	T30
T2139-12.5R-150-C25	●	25	25	160	35			
T2139-12.5R-200-C25	●	25	25	200	40	P3202-D25	P32-M6	T30
T2139-12.5R-250-C25	●	25	25	250	60			
T2139-16R-200-C32	●	32	32	200	55	P3202-D32	P32-M8	T30
T2139-16R-250-C32	●	32	32	250	70			
T2139-16R-300-C32	●	32	32	300	80	P3202-D32	P32-M8	T30

● Stock ○ Available upon Order

Turning inserts
External turning
Internal turning
Grooving & parting
Threading
Milling
Boring & drilling
Tool holder
Solid carbide end mills
Solid carbide drill & taps
Technical information







BAP Shoulder milling cutters

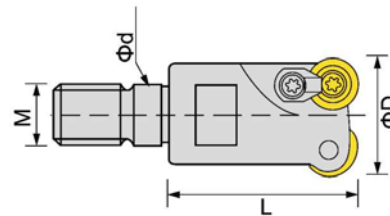

Ordering Code	Stock	Dimensions(mm)				Insert	Screw	Wrench
		D	d	L	M			
BAP3-16-2T-M08	●	16	8.5	25	M8	 AP**1135	 M2.5*6	 T-8
BAP3-17-2T-M08	●	17	8.5	25	M8			
BAP3-20-2T-M10	●	20	10.5	30	M10			
BAP3-21-3T-M10	●	21	10.5	30	M10			
BAP3-25-3T-M12	●	15	12.5	35	M12			
BAP3-26-2T-M12	●	26	12.5	35	M12			
BAP4-25-2T-M12	●	25	12.5	35	M12	 AP**1604	 M4*10	 T-15
BAP4-32-3T-M16	●	32	17	43	M16			
BAP4-35-3T-M16	●	35	17	43	M16			

RP Corner radius milling cutters



Ordering Code	Stock	Dimensions(mm)				Insert	Screw	Wrench
		D	d	L	M			
RD0802-20-2T-M10	●	20	10.5	32	M10	 RD**0802	 M2.5*6	 T-8
RD0802-21-2T-M10	●	21	10.5	32	M10			
RP1003-25-2T-M12	●	25	12.5	35	M12	 RP**1003	 M3.5*8	 T-15
RP1003-26-2T-M12	●	26	12.5	35	M12			
RP1003-30-3T-M12	●	30	12.5	35	M12			
RP1003-32-3T-M16	●	32	17	43	M16			
RP1003-35-3T-M16	●	35	17	43	M16			

● Stock ○ Available upon Order

Turning inserts

External turning

Internal turning

Grooving & parting

Threading

Milling

Boring & drilling

Tool holder

Solid carbide end mills

Solid carbide drill & taps

Technical information

BFR Ball End,milling bar

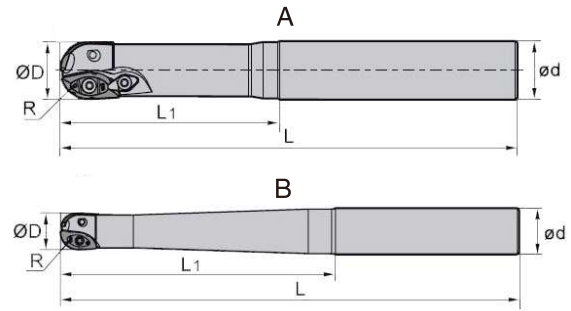

Ordering Code	Stock	Dimensions(mm)				Fig	Insert	Screw	Screw	Wrench
		D	d	L	L1					
BCF-10R-150-C20	●	20	20	150	70	A	ZCEW100CE ZCEW100SE	---	M2.5*6 M3*8	T-7 T-10
BCF-10R-200-C25	●	20	25	200	100	B				
BCF-10R-250-C25	●	20	25	250	150	A	ZCEW125CE ZCEW125SE	---	M4*11	T-15
BCF-12.5R-150-C25	●	25	25	150	80					
BCF-12.5R-200-C25	●	25	25	200	100					
BCF-12.5R-250-C25	●	25	25	250	110					
BCF-12.5R-300-C32	●	25	32	300	120	B	ZCEW150CE ZCEW150SE	---	M4*11 M5*13	T-15 T-20
BCF-15R-160-C32	●	30	32	160	70					
BCF-15R-200-C32	●	30	32	200	100					
BCF-15R-250-C32	●	30	32	250	120					
BCF-16R-160-C32	●	32	32	160	70	A	ZCEW160CE ZCEW160SE	---	M4*11 M5*13	T-15 T-20
BCF-16R-200-C32	●	32	32	200	100					
BCF-16R-250-C32	●	32	32	250	120					
BCF-16R-300-C32	●	32	32	300	150					

Ordering Code	Stock	Dimensions(mm)				Fig	Insert	Screw	Screw	Wrench
		D	d	L	L1					
BCFL-10R-150-C20	●	20	20	150	70	A	ZCEW100CE ZCEW100SE CPMT080204	---	M2.5*6 M3*8	T-7 T-10
BCFL-10R-200-C25	●	20	25	200	100	B				
BCFL-10R-250-C25	●	20	25	250	150	A	ZCEW125CE ZCEW125SE CPMT090308	---	M4*11	T-15
BCFL-12.5R-150-C25	●	25	25	150	80					
BCFL-12.5R-200-C25	●	25	25	200	100					
BCFL-12.5R-250-C25	●	25	25	250	110					
BCFL-12.5R-300-C32	●	25	32	300	120	B	ZCEW150CE ZCEW150SE CPMT090308	---	M4*11 M5*13	T-15 T-20
BCFL-15R-160-C32	●	30	32	160	70					
BCFL-15R-200-C32	●	30	32	200	100					
BCFL-15R-250-C32	●	30	32	250	120					
BCFL-16R-160-C32	●	32	32	160	70	A	ZCEW160CE ZCEW160SE CPMT090308	---	M4*11 M5*13	T-15 T-20
BCFL-16R-200-C32	●	32	32	200	100					
BCFL-16R-250-C32	●	32	32	250	120					
BCFL-16R-300-C32	●	32	32	300	150					

● Stock ○ Available upon Order

Turning inserts
External turning
Internal turning
Grooving & parting
Threading
Milling
Boring & drilling
Tool holder
Solid carbide end mills
Solid carbide drill & taps
Technical information

BAP Straight shank milling cutter BAP series

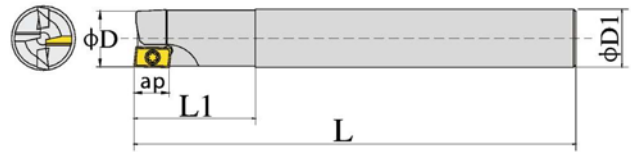

Ordering Code	Stock	Dimensions(mm)					Insert	Screw	Wrench			
		D	D1	L	Z	ap						
BAP300R-10-1T-10-120	●	10	10	120	1	9	AP**1135	M2.5*6	T-8			
BAP300R-12-1T-12-120	●	12	12	120								
BAP300R-16-2T-16-120	●	16	16	120								
BAP300R-16-2T-16-150	●	16	16	150								
BAP300R-16-2T-16-160	●	16	16	160								
BAP300R-16-2T-16-200	●	16	16	200								
BAP300R-20-2T-20-120	●	20	20	120								
BAP300R-20-2T-20-150	●	20	20	150								
BAP300R-20-2T-20-160	●	20	20	160								
BAP300R-20-2T-20-200	●	20	20	200								
BAP300R-25-3T-25-120	●	25	25	120	3	9	M2.5*6	T-8				
BAP300R-25-3T-25-150	●	25	25	150								
BAP300R-25-3T-25-160	●	25	25	160								
BAP300R-25-3T-25-200	●	25	25	200								
BAP300R-32-3T-32-160	●	32	32	160								
BAP300R-32-3T-32-200	●	32	32	200								
BAP300R-32-3T-32-250	●	32	32	250								
BAP400R-25-2T-25-120	●	25	25	120	2				14	AP**1604	M4*10	T-15
BAP400R-25-2T-25-150	●	25	25	150								
BAP400R-25-2T-25-160	●	25	25	160								
BAP400R-25-2T-25-200	●	25	25	200								
BAP400R-25-2T-25-250	●	25	25	250								
BAP400R-32-2T-32-160	●	32	32	160								
BAP400R-32-2T-32-200	●	32	32	200								
BAP400R-32-2T-32-250	●	32	32	250								

● Stock ○ Available upon Order

Turning inserts

External turning

Internal turning

Grooving & parting

Threading

Milling

Boring & drilling

Tool holder

Solid carbide end mills

Solid carbide drill & taps

Technical information

BAP Variable Head, mills BAP series

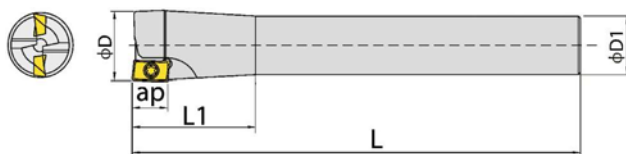

Ordering Code	Stock	Dimensions(mm)					Insert	Screw	Wrench					
		D	D1	L	Z	ap								
BAP300R-17-2T-16-120	●	17	16	120	2	9	AP**1135	M2.5*6	T-8					
BAP300R-17-2T-16-150	●	17	16	150										
BAP300R-17-2T-16-160	●	17	16	160										
BAP300R-17-2T-16-200	●	17	16	200										
BAP300R-21-2T-20-120	●	21	20	120										
BAP300R-21-2T-20-150	●	21	20	150										
BAP300R-21-2T-20-160	●	21	20	160										
BAP300R-21-2T-20-200	●	21	20	200										
BAP300R-26-3T-25-120	●	26	25	120	3	9	AP**1135	M2.5*6	T-8					
BAP300R-26-3T-25-150	●	26	25	150										
BAP300R-26-3T-25-160	●	26	25	160										
BAP300R-26-3T-25-200	●	26	25	200										
BAP300R-26-3T-25-250	●	26	25	250										
BAP300R-32-3T-25-120	●	32	25	120										
BAP300R-32-3T-25-150	●	32	25	150										
BAP300R-32-3T-25-160	●	32	25	160										
BAP300R-32-3T-25-200	●	32	25	200	2	14	AP**1604	M4*10	T-15					
BAP300R-32-3T-25-250	●	32	25	250										
BAP300R-35-3T-32-160	●	35	32	160										
BAP300R-35-3T-32-200	●	35	32	200										
BAP300R-35-3T-32-250	●	35	32	250										
BAP400R-26-2T-25-120	●	26	25	120						3	14	AP**1604	M4*10	T-15
BAP400R-26-2T-25-150	●	26	25	150										
BAP400R-26-2T-25-160	●	26	25	160										
BAP400R-26-2T-25-200	●	26	25	200										
BAP400R-26-2T-25-250	●	26	25	250										
BAP400R-32-2T-25-160	●	32	25	160										
BAP400R-32-2T-25-200	●	32	25	200										
BAP400R-32-2T-25-250	●	32	25	250										
BAP400R-35-3T-32-160	●	35	32	160	3	14	AP**1604	M4*10	T-15					
BAP400R-35-3T-32-200	●	35	32	200										
BAP400R-35-3T-32-250	●	35	32	250										

● Stock ○ Available upon Order

- Turning inserts
- External turning
- Internal turning
- Grooving & parting
- Threading
- Milling
- Boring & drilling
- Tool holder
- Solid carbide end mills
- Solid carbide drill & taps
- Technical information

BRP Straight shank milling cutter BRP series

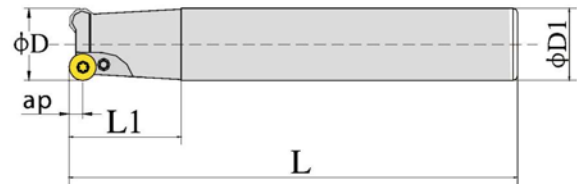

Ordering Code	Stock	Dimensions(mm)					Insert	Screw	Wrench	Clamp
		D	D1	L	Z	ap				
BRP4R-16-2T-16-120	●	16	16	120	2	4	RP**08T2	M3.0*6	T-10	R4YD
BRP4R-16-2T-16-150	●	16	16	150						
BRP4R-16-2T-16-160	●	16	16	160						
BRP4R-16-2T-16-200	●	16	16	200						
BRP4R-20-2T-20-120	●	20	20	120						
BRP4R-20-2T-20-150	●	20	20	150						
BRP4R-20-2T-20-160	●	20	20	160						
BRP4R-20-2T-20-200	●	20	20	200						
BRP4R-25-3T-25-120	●	25	25	120	3	5	RP**10T3	M3.5*8	T-15	R5YD
BRP4R-25-3T-25-150	●	25	25	150						
BRP4R-25-3T-25-160	●	25	25	160						
BRP4R-25-3T-25-200	●	25	25	200						
BRP5R-16-1T-16-120	●	16	16	120	1	5	RP**10T3	M3.5*8	T-15	R5YD
BRP5R-16-1T-16-160	●	16	16	160						
BRP5R-16-1T-16-200	●	16	16	200						
BRP5R-20-1T-20-120	●	20	20	120						
BRP5R-20-1T-20-160	●	20	20	160						
BRP5R-20-1T-20-200	●	20	20	200						
BRP5R-25-2T-25-120	●	25	25	120	2	5	RP**10T3	M3.5*8	T-15	R5YD
BRP5R-25-2T-25-160	●	25	25	160						
BRP5R-25-2T-25-200	●	25	25	200						
BRP5R-25-2T-25-250	●	25	25	250						
BRP5R-32-3T-32-160	●	32	32	160	3	5	RP**10T3	M3.5*8	T-15	R5YD
BRP5R-32-3T-32-200	●	32	32	200						
BRP5R-32-3T-32-250	●	32	32	250						
BRP6R-25-2T-25-160	●	25	25	160	2	6	RP**1204	M4.0*10	T-15	R6YD
BRP6R-25-2T-25-200	●	25	25	200						
BRP6R-25-2T-25-250	●	25	25	250	3					
BRP6R-32-3T-32-160	●	32	32	160						
BRP6R-32-3T-32-200	●	32	32	200						
BRP6R-32-3T-32-250	●	32	32	250						

● Stock ○ Available upon Order

Turning inserts

External turning

Internal turning

Grooving & parting

Threading

Milling

Boring & drilling

Tool holder

Solid carbide end mills

Solid carbide drill & taps

Technical information

BRP Mills, variable head BRP series

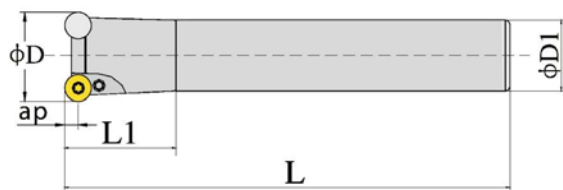

Ordering Code	Stock	Dimensions(mm)					Insert	Screw	Wrench	Clamp
		D	D1	L	Z	ap				
BRP4R-17-2T-16-120	●	17	16	120	2	4	RP**08T2	M3.0*6	T-10	R4YD
BRP4R-17-2T-16-160	●	17	16	160						
BRP4R-17-2T-16-200	●	17	16	200						
BRP4R-21-2T-20-120	●	21	20	120						
BRP4R-21-2T-20-160	●	21	20	160						
BRP4R-21-2T-20-200	●	21	20	200						
BRP4R-26-3T-25-120	●	26	25	120	3					
BRP4R-26-3T-25-160	●	26	25	160						
BRP4R-26-3T-25-200	●	26	25	200						
BRP5R-17-1T-16-120	●	17	16	120	1					
BRP5R-17-1T-16-160	●	17	16	160						
BRP5R-17-1T-16-200	●	17	16	200						
BRP5R-21-1T-20-120	●	21	20	120						
BRP5R-21-1T-20-160	●	21	20	160						
BRP5R-21-1T-20-200	●	21	20	200	2	5	RP**10T3	M3.5*8	T-15	R5YD
BRP5R-26-2T-25-120	●	26	25	120						
BRP5R-26-2T-25-160	●	26	25	160						
BRP5R-26-2T-25-200	●	26	25	200						
BRP5R-26-2T-25-250	●	26	25	250	3					
BRP5R-32-3T-25-160	●	32	25	160						
BRP5R-32-3T-25-200	●	32	25	200						
BRP5R-32-3T-25-250	●	32	25	250						
BRP5R-35-3T-32-160	●	35	32	160						
BRP5R-35-3T-32-200	●	35	32	200	2					
BRP5R-35-3T-32-250	●	35	32	250						
BRP6R-26-2T-25-160	●	26	25	160						
BRP6R-26-2T-25-200	●	26	25	200	2					
BRP6R-26-2T-25-250	●	26	25	250						
BRP6R-32-3T-25-160	●	32	25	160	3	6	RP**1204	M4.0*10	T-15	R6YD
BRP6R-32-3T-25-200	●	32	25	200						
BRP6R-32-3T-25-250	●	32	25	250						
BRP6R-35-3T-32-160	●	35	32	160						
BRP6R-35-3T-32-200	●	35	32	200						
BRP6R-35-3T-32-250	●	35	32	250						

● Stock ○ Available upon Order

- Turning inserts
- External turning
- Internal turning
- Grooving & parting
- Threading
- Milling
- Boring & drilling
- Tool holder
- Solid carbide end mills
- Solid carbide drill & taps
- Technical information

BRD Straight shank milling cutter BRD series

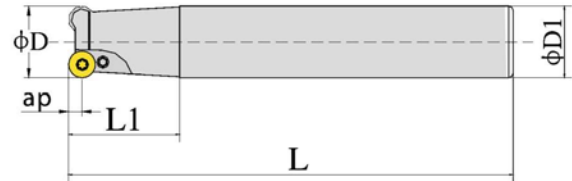

Ordering Code	Stock	Dimensions(mm)					Insert	Screw	Wrench	Clamp
		D	D1	L	Z	ap				
BRD4R-16-2T-16-120	●	16	16	120	2	4	RD**0802	M3.0*6	T-10	R4YD
BRD4R-16-2T-16-150	●	16	16	150						
BRD4R-16-2T-16-160	●	16	16	160						
BRD4R-16-2T-16-200	●	16	16	200						
BRD4R-20-2T-20-120	●	20	20	120						
BRD4R-20-2T-20-150	●	20	20	150						
BRD4R-20-2T-20-160	●	20	20	160						
BRD4R-20-2T-20-200	●	20	20	200						
BRD4R-25-3T-25-120	●	25	25	120	3	5	RD**10T3	M3.5*8	T-15	R5YD
BRD4R-25-3T-25-150	●	25	25	150						
BRD4R-25-3T-25-160	●	25	25	160						
BRD4R-25-3T-25-200	●	25	25	200						
BRD5R-16-1T-16-120	●	16	16	120	1	5	RD**10T3	M3.5*8	T-15	R5YD
BRD5R-16-1T-16-160	●	16	16	160						
BRD5R-16-1T-16-200	●	16	16	200						
BRD5R-20-1T-20-120	●	20	20	120						
BRD5R-20-1T-20-160	●	20	20	160						
BRD5R-20-1T-20-200	●	20	20	200	2	5	RD**10T3	M3.5*8	T-15	R5YD
BRD5R-25-2T-25-120	●	25	25	120						
BRD5R-25-2T-25-160	●	25	25	160						
BRD5R-25-2T-25-200	●	25	25	200	3	5	RD**10T3	M3.5*8	T-15	R5YD
BRD5R-25-2T-25-250	●	25	25	250						
BRD5R-32-3T-32-160	●	32	32	160	3	5	RD**10T3	M3.5*8	T-15	R5YD
BRD5R-32-3T-32-200	●	32	32	200						
BRD5R-32-3T-32-250	●	32	32	250						
BRD6R-25-2T-25-160	●	25	25	160	2	6	RD**1204	M4.0*10	T-15	R6YD
BRD6R-25-2T-25-200	●	25	25	200						
BRD6R-25-2T-25-250	●	25	25	250	3	6	RD**1204	M4.0*10	T-15	R6YD
BRD6R-32-3T-32-160	●	32	32	160						
BRD6R-32-3T-32-200	●	32	32	200						
BRD6R-32-3T-32-250	●	32	32	250						

● Stock ○ Available upon Order

Turning inserts

External turning

Internal turning

Grooving & parting

Threading

Milling

Boring & drilling

Tool holder

Solid carbide end mills

Solid carbide drill & taps

Technical information

BRD Mills, variable head BRD series

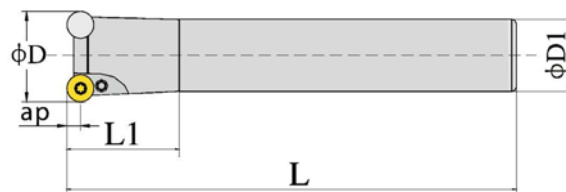

Ordering Code	Stock	Dimensions(mm)					Insert	Screw	Wrench	Clamp
		D	D1	L	Z	ap				
BRD4R-17-2T-16-120	●	17	16	120	2	4	RD**0802	M3.0*6	T-10	R4YD
BRD4R-17-2T-16-160	●	17	16	160						
BRD4R-17-2T-16-200	●	17	16	200						
BRD4R-21-2T-20-120	●	21	20	120						
BRD4R-21-2T-20-160	●	21	20	160						
BRD4R-21-2T-20-200	●	21	20	200						
BRD4R-26-3T-25-120	●	26	25	120	3					
BRD4R-26-3T-25-160	●	26	25	160						
BRD4R-26-3T-25-200	●	26	25	200						
BRD5R-17-1T-16-120	●	17	16	120	1					
BRD5R-17-1T-16-160	●	17	16	160						
BRD5R-17-1T-16-200	●	17	16	200						
BRD5R-21-1T-20-120	●	21	20	120						
BRD5R-21-1T-20-160	●	21	20	160						
BRD5R-21-1T-20-200	●	21	20	200	2	5	RD**10T3	M3.5*8	T-15	R5YD
BRD5R-26-2T-25-120	●	26	25	120						
BRD5R-26-2T-25-160	●	26	25	160						
BRD5R-26-2T-25-200	●	26	25	200						
BRD5R-26-2T-25-250	●	26	25	250	3					
BRD5R-32-3T-25-160	●	32	25	160						
BRD5R-32-3T-25-200	●	32	25	200						
BRD5R-32-3T-25-250	●	32	25	250						
BRD5R-35-3T-32-160	●	35	32	160						
BRD5R-35-3T-32-200	●	35	32	200	2					
BRD5R-35-3T-32-250	●	35	32	250						
BRD6R-26-2T-25-160	●	26	25	160						
BRD6R-26-2T-25-200	●	26	25	200	2					
BRD6R-26-2T-25-250	●	26	25	250						
BRD6R-32-3T-25-160	●	32	25	160	3	6	RD**1204	M4.0*10	T-15	R6YD
BRD6R-32-3T-25-200	●	32	25	200						
BRD6R-32-3T-25-250	●	32	25	250						
BRD6R-35-3T-32-160	●	35	32	160						
BRD6R-35-3T-32-200	●	35	32	200						
BRD6R-35-3T-32-250	●	35	32	250						

● Stock ○ Available upon Order

- Turning inserts
- External turning
- Internal turning
- Grooving & parting
- Threading
- Milling
- Boring & drilling
- Tool holder
- Solid carbide end mills
- Solid carbide drill & taps
- Technical information

DX45 Pilot drill series



Ordering Code	Stock	Dimensions(mm)		Insert	Screw	Wrench
		D	L			
DX45-16-120	●	20	120	TCGT16T302	M4.0*10	T-15

B30TC Chamfer cutter BTC series

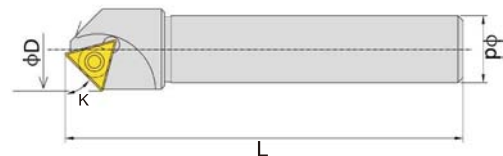

Ordering Code	Stock	Dimensions(mm)					Insert	Screw	Wrench
		D	d	L	Z	K			
B30TC11 20 1T20-120	●	20	20	120	1	30°	TC**1102	M2.5*6	T-8
B30TC11 25 2T20-120	●	25	20	120	2	30°			
B45TC11 20 1T20-120	●	20	20	120	1	45°			
B45TC11 25 2T20-120	●	25	20	120	2	45°			
B60TC11 20 1T20-120	●	20	20	120	1	60°			
B60TC11 25 2T20-120	●	25	20	120	2	60°			
B30TC16 20 1T20-120	●	20	20	120	1	30°	TC**16T3	M2.5*7	T-9
B30TC16 32 2T25-120	●	32	25	120	2	30°			
B45TC16 20 1T20-120	●	20	20	120	1	45°			
B45TC16 32 2T25-120	●	32	25	120	2	45°			
B60TC16 20 1T20-120	●	20	20	120	1	60°			
B60TC16 32 2T25-120	●	32	25	120	2	60°			

● Stock ○ Available upon Order

Turning inserts

External turning

Internal turning

Grooving & parting

Threading

Milling

Boring & drilling

Tool holder

Solid carbide end mills

Solid carbide drill & taps

Technical information

TP Chamfer cutter bar

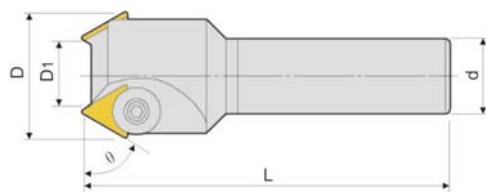

Ordering Code	Stock	Dimensions(mm)						Insert	Screw	Wrench
		D	D1	d	L	Z	K			
TP60-C25-40-120-2T	●	37.7	15.8	25	120	2	60°	TP**1603	M060H080	L4.0
TP45-C20-20-120-1T	●	20.4	4	20	120	1	45°			
TP45-C20-32-120-2T	●	30.2	12	20	120	2	45°			
TP45-C25-50-160-3T	●	49	24	25	160	3	45°	TP**2204	M080H120	L5.0
TP30-C25-40-120-2T	●	39	26	25	120	2	30°	TP**1603	M060H080	L4.0
TP30-C32-55-160-3T	●	54.5	36	32	160	3	30°	TP**2204	M080H120	L5.0

B45SC Chamfer cutter BSC series(Multi-purpose)

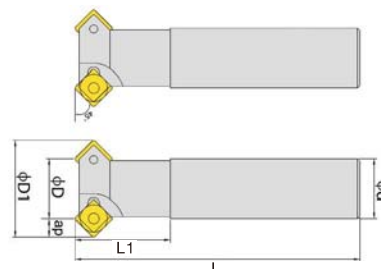

Ordering Code	Stock	Dimensions(mm)						Insert	Screw	Wrench
		D	D1	d	L	Z	K			
B45SC-09-1T20-120	●	9	22.6	20	120	1	45°	SC**09T3	M3.5*8	T-15
B45SC-19-2T20-120	●	19	32.1	20	120	2	45°			
B45SC-25-2T25-120	●	25	41.3	25	120	2	45°			

● Stock ○ Available upon Order

Turning inserts

External turning

Internal turning

Grooving & parting

Threading

Milling

Boring & drilling

Tool holder

Solid carbide end mills

Solid carbide drill & taps

Technical information

AJU Center drilling mills

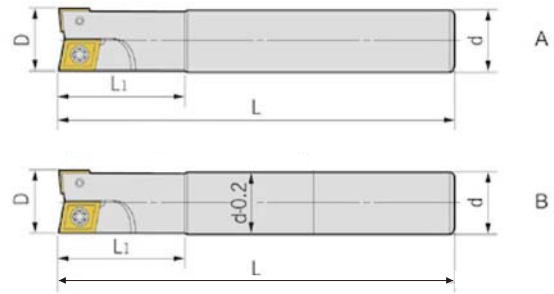

Ordering Code	Stock	Dimensions(mm)					Z	Insert	Screw	Wrench
		D	d	L	L1	Z				
AJU-C16-16-120-2T	●	16	16	120	35	2	CCMT060204	M2.5*6	T-8	
AJU-C16-16-150-2T	●	16	16	150	35		CPMT080204Z			
AJU-C16-16-200-2T	●	16	16	200	40					
AJU-C20-20-160-2T	●	20	20	160	50		CCMT060204	M2.5*6	T-8	
AJU-C20-20-200-2T	●	20	20	200	60		CPMT090204Z	M3.5*8	T-15	
AJU-C25-25-160-2T	●	25	25	160	60		CCMT090308	M4.0*8	T-15	
AJU-C25-25-200-2T	●	25	25	200	70		CPMT120308Z			
AJU-C25-25-250-2T	●	25	25	250	80					
AJU-C32-32-200-2T	●	32	32	200	60		CPMT120408	M5.0*11	T-20	
AJU-C32-32-250-2T	●	32	32	250	70		CPMT160408Z			

ATS T-Slot Milling cutter

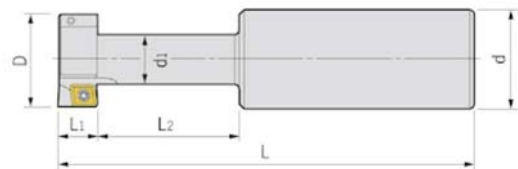

Ordering Code	Stock	Dimensions(mm)						Insert	Screw	Wrench
		D	d	d1	L	L1	L2			
ATS25-C25-120-2T-06	●	25	25	12.5	120	11	21	CCMT060204	M2.5*6	T-8
ATS30-C25-120-4T-06	●	30	25	15	120	14	30	CCMT060204		
ATS32-C25-120-4T-08	●	32	25	16	120	14	30	CPMT080204		
ATS35-C32-120-4T-09	●	35	25	17.5	120	18	32	CCMT09T308	M4.0*8	T-15
ATS40-C32-120-4T-09	●	40	32	20	120	18	32	CCMT09T308		
ATS50-C32-120-4T-12	●	50	32	25	120	22	39	CCMT120408	M5.0*11	T-20

● Stock ○ Available upon Order

Turning inserts

External turning

Internal turning

Grooving & parting

Threading

Milling

Boring & drilling

Tool holder

Solid carbide end mills

Solid carbide drill & taps

Technical information

BUD

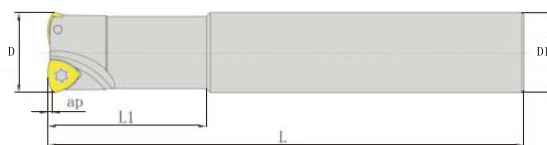

Ordering Code	Stock	Dimensions(mm)						Insert	Screw	Wrench
		D	D1	L	L1	ap	Z			
BUD08-20-2T20-120	○	20	20	120	40	1.0	2	UD**0803	M3*7	T-8
BUD08-20-2T20-160	○	20	20	160	50	1.0				
BUD08-20-2T20-200	○	20	20	200	60	1.0				
BUD08-25-2T25-120	○	25	25	120	40	1.0				
BUD08-25-2T25-160	○	25	25	160	50	1.0				
BUD08-25-2T25-200	○	25	25	200	60	1.0				
BUD12-25-2T25-160	○	25	25	160	50	1.5	3	UD**12T3	M4*10	T-15
BUD12-25-2T25-200	○	25	25	200	60	1.5				
BUD12-32-3T32-160	○	32	32	160	50	1.5				
BUD12-32-3T32-200	○	32	32	200	60	1.5				

BUD

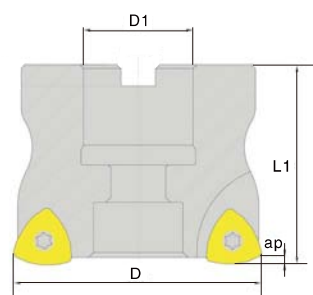

Ordering Code	Stock	Dimensions(mm)						Insert	Screw	Wrench
		D	D1	L1	ap	Z				
BUD12-050-4T-22	○	50	22	50	1.5	4	UD**12T3	M4*10	T-15	
BUD12-063-4T-22	○	63	22	50		4				
BUD12-080-5T-27	○	80	27	50		5				
BUD12-100-6T-32	○	100	32	50		6				

● Stock ○ Available upon Order

- Turning inserts
- External turning
- Internal turning
- Grooving & parting
- Threading
- Milling
- Boring & drilling
- Tool holder
- Solid carbide end mills
- Solid carbide drill & taps
- Technical information

BAP Mills series

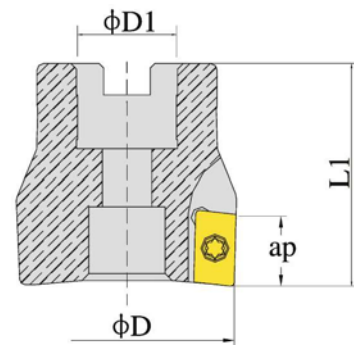

Ordering Code	Stock	Dimensions(mm)					Insert	Screw	Wrench
		D	D1	L1	ap	Z			
BAP400R 050 4T 22	●	50	22	50	16	4	AP**1604	M4*10	T-15
BAP400R 063 4T 22	●	63	22	50		4			
BAP400R 063 5T 22	●	63	22	50		5			
BAP400R 080 6T 27	●	80	27	50		6			
BAP400R 100 6T 32	●	100	32	50		6			
BAP400R 125 6T 40	●	125	40	63		6			
BAP400R 050 4T 25.4	○	50	25.4	50		4			
BAP400R 063 5T 25.4	○	63	25.4	50		5			
BAP400R 080 6T 25.4	○	80	25.4	50		6			
BAP400R 100 6T 31.75	○	100	31.75	50		6			

BRP Mills series

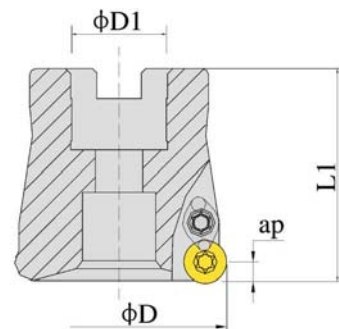

Ordering Code	Stock	Dimensions(mm)					Insert	Screw	Wrench	Clamp
		D	D1	L1	ap	Z				
BRP 5R 050 4T 22	●	50	22	50	5	RP**1003	M3.5*8	T-15	R5YD	
BRP 5R 063 4T 22	●	63	22	50						4
BRP 5R 063 5T 22	●	63	22	50						5
BRP 5R 080 6T 27	●	80	27	50						6
BRP 5R 100 6T 32	●	100	32	50	6					
BRP 6R 050 4T 22	●	50	22	50	6	RP**1204	M4.0*10	T-15	R6YD	
BRP 6R 063 4T 22	●	63	22	50						4
BRP 6R 080 6T 27	●	80	27	50						6
BRP 6R 100 6T 32	●	100	32	50						6

● Stock ○ Available upon Order

Turning inserts

External turning

Internal turning

Grooving & parting

Threading

Milling

Boring & drilling

Tool holder

Solid carbide end mills

Solid carbide drill & taps

Technical information

BRD Mills series

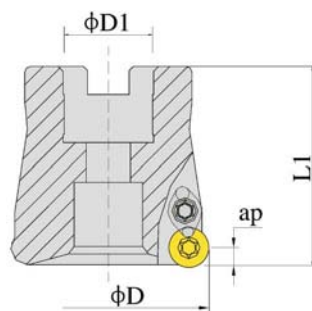

Ordering Code	Stock	Dimensions(mm)					Insert	Screw	Wrench	Clamp
		D	D1	L1	ap	Z				
BRD 5R 050 4T 22	●	50	22	50	5	4	RD**10T3	M3.5*8	T-15	R5YD
BRD 5R 063 4T 22	●	63	22	50		4				
BRD 5R 063 5T 22	●	63	22	50		5				
BRD 5R 080 6T 27	●	80	27	50		6				
BRD 5R 100 6T 32	●	100	32	50		6				
BRD 5R 125 7T 40	●	125	40	63		7				
BRD 5R 050 4T 25.4	○	50	25.4	50		4				
BRD 5R 063 4T 25.4	○	63	25.4	50		4				
BRD 5R 080 6T 25.4	○	80	25.4	50		6				
BRD 5R 100 6T 31.75	○	100	31.75	50		6				
BRD 5R 125 7T 38.1	○	125	38.1	63		7				
BRD 6R 050 4T 22	●	50	22	50	6	4	RD**1204	M4.0*10	T-15	R6YD
BRD 6R 063 4T 22	●	63	22	50		4				
BRD 6R 063 5T 22	●	63	22	50		5				
BRD 6R 080 6T 27	●	80	27	50		6				
BRD 6R 100 6T 32	●	100	32	50		6				
BRD 6R 125 7T 40	●	125	40	63		7				
BRD 6R 050 4T 25.4	○	50	25.4	50		4				
BRD 6R 063 4T 25.4	○	63	25.4	50		4				
BRD 6R 080 6T 25.4	○	80	25.4	50		6				
BRD 6R 100 6T 31.75	○	100	31.75	50		6				
BRD 6R 125 7T 38.1	○	125	38.1	63		7				
BRD 8R 063 4T 22	●	63	22	50	8	4	RD**1604	M5.0*12	T-20	R6YD
BRD 8R 080 5T 27	●	80	27	50		5				
BRD 8R 100 6T 32	●	100	32	50		6				
BRD 8R 125 7T 40	●	125	40	63		7				
BRD 8R 160 8T 40	●	160	40	63		8				
BRD 10R 100 6T 40	○	100	31.75	50	10	6	RD**2006			R10YD
BRD 10R 125 7T 40	○	125	38.1	63		7				
BRD 10R 160 8T 60	○	160	50.8	63		8				

● Stock ○ Available upon Order

- Turning inserts
- External turning
- Internal turning
- Grooving & parting
- Threading
- Milling
- Boring & drilling
- Tool holder
- Solid carbide end mills
- Solid carbide drill & taps
- Technical information

BAN

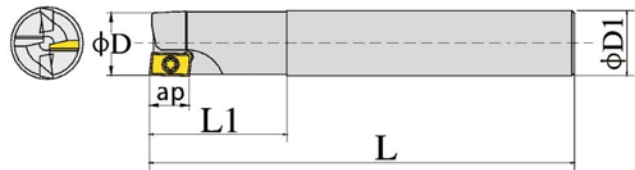

Ordering Code	Stock	Dimensions(mm)						Insert	Screw	Wrench				
		D	D1	L	L1	ap	Z							
BAN08-1616T2-125	●	16	16	125	26	8	2							
BAN08-1616T2-160	○	16	16	160							3			
BAN08-2020T3-125	●	20	20	125								3		
BAN08-2020T3-160	○	20	20	160									4	
BAN08-2525T4-125	●	25	25	125										4
BAN08-2525T4-160	○	25	25	160										
BAN08-3232T5-160	○	32	32	160		2								
BAN13-2525T2-125	●	25	25	125						2				
BAN13-2525T2-160	○	25	25	160							3			
BAN13-3232T3-160	●	32	32	160								3		
BAN13-3232T3-200	○	32	32	200									4	
BAN13-4040T4-160	○	40	40	160										4
BAN13-4040T4-200	○	40	40	200										

BAN

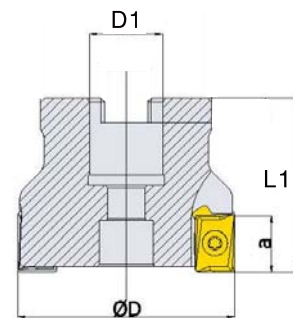

Ordering Code	Stock	Dimensions(mm)					Insert	Screw	Wrench						
		D	D1	L1	ap	Z									
BAN16D050T4-22	●	50	22	50	16	4									
BAN16D063T5-22	●	63	22	50						5					
BAN16D080T6-27	●	80	27	50							6				
BAN16D100T7-32	●	100	32	50								7			
BAN16D125T8-40	●	125	40	63									8		
BAN16D160T10-40	○	160	40	63										10	
BAN16D200T12-60	○	200	60	63											12
BAN16D250T14-60	○	250	60	63											

● Stock ○ Available upon Order

Turning inserts

External turning

Internal turning

Grooving & parting

Threading

Milling

Boring & drilling

Tool holder

Solid carbide end mills

Solid carbide drill & taps

Technical information

SONFM

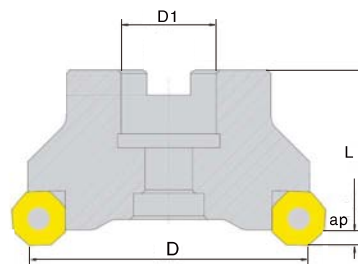

Ordering Code	Stock	Dimensions(mm)					Insert	Screw	Wrench
		D	D1	L	ap	Z			
SONFM45D050T04-22	●	50	22	50	3-6	4	 SN**1205 ON**1205	 SNON-M4.0	 T-15
SONFM45D063T05-22	●	63	22	50		5			
SONFM45D080T06-27	●	80	27	50		6			
SONFM45D100T07-32	●	100	32	50		7			
SONFM45D125T08-40	●	125	40	63		8			
SONFM45D160T10-40	●	160	40	63		10			
SONFM45D200T12-60	●	200	60	63		12			
SONFM45D250T14-60	●	250	60	63		14			
SONFM45D315T18-60	●	315	60	63		18			

TFM55° Facing mills series

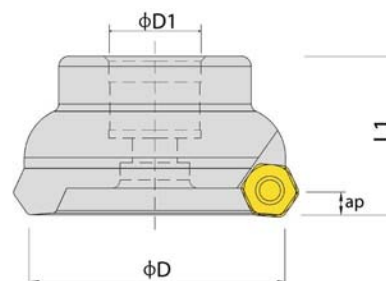

Ordering Code	Stock	Dimensions(mm)					Insert	Screw	Wrench
		D	D1	L1	ap	Z			
TFM55AHNS 050 4T 22	●	50	22	50	4	 HN**0504	 M4.5*12	 T-20	
TFM55AHNS 063 5T 22	●	63	22	50					5
TFM55AHNS 080 6T 27	●	80	27	50					6
TFM55AHNS 100 7T 32	●	100	32	50					7
TFM55AHNS 125 8T 40	●	125	40	63					8
TFM55AHNS 160 9T 40	●	160	40	63					9

● Stock ○ Available upon Order

Turning inserts
External turning
Internal turning
Grooving & parting
Threading
Milling
Boring & drilling
Tool holder
Solid carbide end mills
Solid carbide drill & taps
Technical information

SE45° Facing mills series

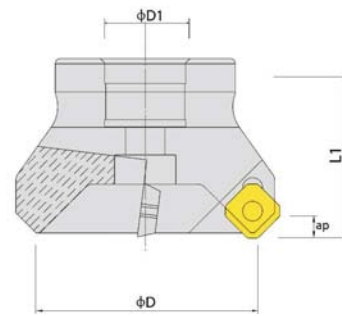

Ordering Code	Stock	Dimensions(mm)					Insert	Screw	Wrench	
		D	D1	L1	ap	Z				
SE13 050 4T 22	●	50	22	50	5	4	SE**13T3	M3.5*8	T-15	
SE13 063 5T 22	●	63	22	50						5
SE13 080 5T 27	●	80	27	50						5
SE13 100 6T 32	●	100	32	50						6
SE13 125 7T 40	●	125	40	63						7
SE13 160 8T 40	●	160	40	63						8
SE13 200 10T 60	●	200	60	63						10

BSE45° Straight shank facing mills series

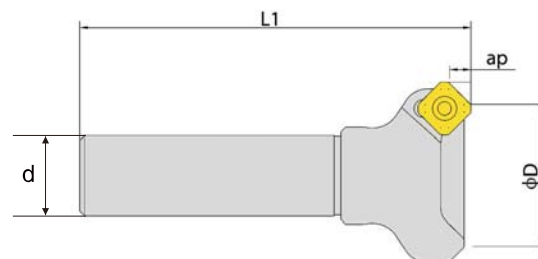

Ordering Code	Stock	Dimensions(mm)					Insert	Screw	Wrench	
		D	d	L1	ap	Z				
BSE13 050 4T 120	●	50	32	120	6	4	SE**13T3	M3.5*8	T-15	
BSE13 063 5T 120	●	63								5
BSE13 080 5T 120	●	80								5
BSE13 100 6T 120	●	100								6

● Stock ○ Available upon Order

Turning inserts

External turning

Internal turning

Grooving & parting

Threading

Milling

Boring & drilling

Tool holder

Solid carbide end mills

Solid carbide drill & taps

Technical information

SE45° Facing mills series

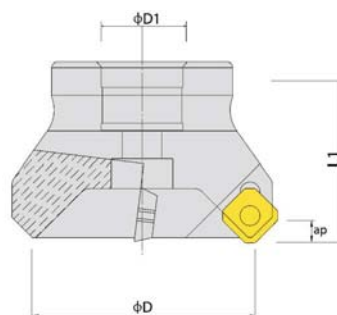

Ordering Code	Stock	Dimensions(mm)					Insert	Screw	Wrench
		D	D1	L1	ap	Z			
SE12 050 4T 22	●	50	22	50	5	4	SE**1204	M5.0*12	T-20
SE12 063 5T 22	●	63	22	50		5			
SE12 080 5T 27	●	80	27	50		5			
SE12 100 6T 32	●	100	32	50		6			
SE12 125 7T 40	●	125	40	63		7			
SE12 160 8T 40	●	160	40	63		8			
SE12 200 10T 60	●	200	60	63		10			

FM

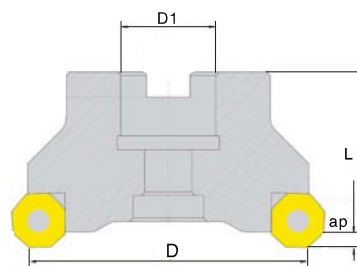

Ordering Code	Stock	Dimensions(mm)					Insert	Screw	Wrench
		D	D1	L	ap	Z			
FM45-D050T04-22-OD06	●	50	22	50	4	4	OD**0605	M5*12	T-20
FM45-D063T05-22-OD06	●	63	22	50		5			
FM45-D080T06-27-OD06	●	80	27	50		6			
FM45-D100T07-32-OD06	●	100	32	50		7			
FM45-D125T08-40-OD06	●	125	40	63		8			
FM45-D160T10-40-OD06	●	160	40	63		10			
FM45-D200T12-60-OD06	●	200	60	63		12			

● Stock ○ Available upon Order

- Turning inserts
- External turning
- Internal turning
- Grooving & parting
- Threading
- Milling
- Boring & drilling
- Tool holder
- Solid carbide end mills
- Solid carbide drill & taps
- Technical information

BM90° Corn mills

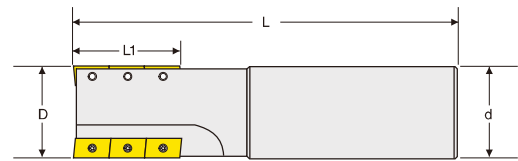

Ordering Code	Stock	Dimensions(mm)					Insert	Screw	Wrench
		D	d	L	L1	Z			
TAP11-20C20-28M-2T120	●	20	20	120	28	2	APMT1135	M2.5*6	T-18
TAP11-25C25-38M-2T130	●	25	25	130	38	2			
TAP11-25C25-48M-2T130	●	25	25	130	48	2			
TAP11-32C32-48M-3T140	●	32	32	140	48	3	APMT1604	M4*10	T-15
TAP16-32C32-70M-2T150	●	32	32	150	70	2			
TAP16-40C32-70M-2T150	●	40	32	150	70	2			
TAP16-40C32-70M-3T150	●	40	32	150	70	3			
TAP16-50C32-70M-3T150	●	50	32	150	70	3			

BM90° Corn mills

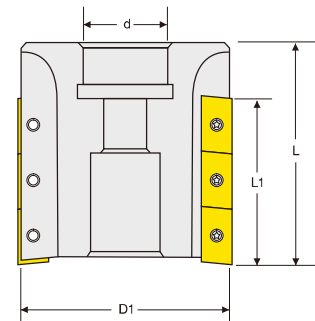

Ordering Code	Stock	Dimensions(mm)					Insert	Screw	Wrench
		D	d	L	L1	Z			
TAP16-D050-22-42M3T	●	50	22	120	42	3	APMT1604	M4*10	T-15
TAP16-D063-27-42M4T	●	63	27		42	4			
TAP16-D063-27-60M4T	●	63	27		60	4			
TAP16-D080-32-72M5T	●	80	32		72	5			

● Stock ○ Available upon Order

Turning inserts

External turning

Internal turning

Grooving & parting

Threading

Milling

Boring & drilling

Tool holder

Solid carbide end mills

Solid carbide drill & taps

Technical information

BT Corn mills

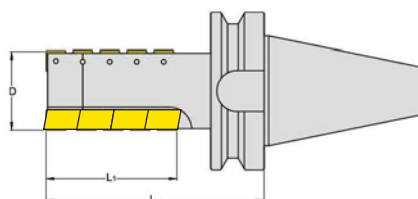

Ordering Code	Stock	Dimensions(mm)				Insert	Screw	Wrench
		D	L	L1	Z			
BT50-D50-70M4T-AP16	●	50		70	4	APMT1604	M4*10	T-15
BT50-D63-70M4T-AP16	●	63		70	4			
BT50-D63-85M4T-AP16	●	63		85	4			
BT50-D63-100M4T-AP16	●	63		100	5			
BT50-D80-99M5T-AP16	●	80		99	5			
BT50-D80-120M5T-AP16	●	80		120	5			
BT50-D100-118M6T-AP16	●	100		118	6			
BT50-D100-160M6T-AP16	●	100		160	6			
BT50-D100-280M6T-AP16	●	100		280	6			

HMC Corn mills

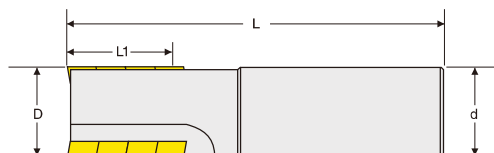





Ordering Code	Stock	Dimensions(mm)					Insert	Screw	Wrench
		D	d	L	L1	Z			
HMC90-025.029.2T25-CN07	●	25	25	106	29	2	CN**07	M3*12	T-9
HMC90-032.035.2T32-CN07	●	32	32	117	35	2			
HMC90-040.040.3T32-CN07	●	40	32	125	40	3			

● Stock ○ Available upon Order

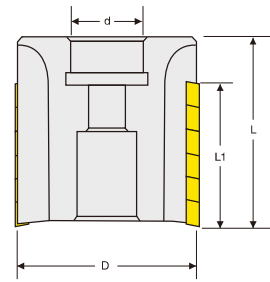
Turning inserts
External turning
Internal turning
Grooving & parting
Threading
Milling
Boring & drilling
Tool holder
Solid carbide end mills
Solid carbide drill & taps
Technical information



HMC Corn mills

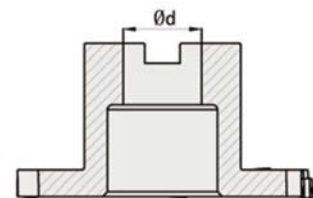
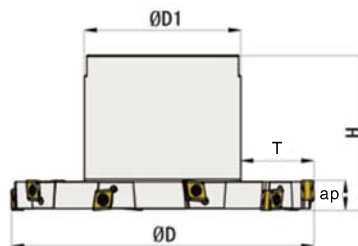

Ordering Code	Stock	Dimensions(mm)					Insert 	Screw 	Wrench 
		D	d	L	L1	Z			
HMC90-050.052.4T22-CN07	●	50	22	70	52	4	CN**07	M3*12	T-9
HMC90-063.052.4T22-CN07	●	63	22		52	5			
HMC90-080.052.5T27-CN07	●	80	27		52	5			

TMR Side and face milling



Ordering Code	Stock	Dimensions(mm)							Insert 	Screw 	Wrench 
		D	d	L	ap	Z	T				
TMR-063.H10.05T22-CN07	●	63	22	50	10	5	10	CN**07	M3*12	T-9	
TMR-080.H10.06T27-CN07	●	80	27	50	10	6	14				
TMR-100.H10.08T32-CN07	●	100	32	50	10	8	19				
TMR-125.H10.10T32-CN07	●	125	32	63	10	10	29				
TMR-160.H10.12T40-CN07	●	160	40	63	10	12	43				
TMR-063.H12.05T22-CN07	●	63	22	50	12	5	10				
TMR-080.H12.06T27-CN07	●	80	27	50	12	6	14				
TMR-100.H12.08T32-CN07	●	100	32	50	12	8	19				
TMR-125.H12.10T32-CN07	●	125	32	63	12	10	29				
TMR-160.H12.12T40-CN07	●	160	40	63	12	12	43				

● Stock ○ Available upon Order

Turning inserts

External turning

Internal turning

Grooving & parting

Threading

Milling

Boring & drilling

Tool holder

Solid carbide end mills

Solid carbide drill & taps

Technical information

SMR Side and face mills

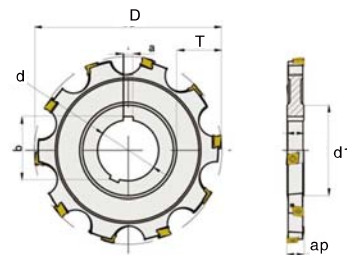

Ordering Code	Stock	Dimensions(mm)						Insert	Screw	Wrench
		D	d	d1	ap	Z	T			
SMR-063.H10.05T22-CN07	●	63	22	50	10	5	10	CN**07	M3*12	T-9
SMR-080.H10.06T27-CN07	●	80	27	50	10	6	14			
SMR-100.H10.08T32-CN07	●	100	32	50	10	8	19			
SMR-125.H10.10T32-CN07	●	125	32	63	10	10	29			
SMR-160.H10.12T40-CN07	●	160	40	63	10	12	43			
SMR-063.H12.05T22-CN07	●	63	22	50	12	5	10			
SMR-080.H12.06T27-CN07	●	80	27	50	12	6	14			
SMR-100.H12.08T32-CN07	●	100	32	50	12	8	19			
SMR-125.H12.10T32-CN07	●	125	32	63	12	10	29			
SMR-160.H12.12T40-CN07	●	160	40	63	12	12	43			

STF Slot mills

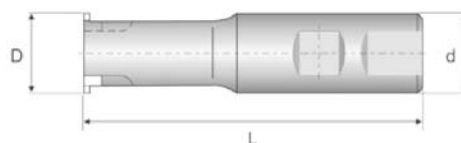

Ordering Code	Stock	Dimensions(mm)						Insert	Screw	Wrench
		D	d	L	T	Z				
STF-2520.1T.GBA32-100L	●	20	16	100	0.8-2.0	1	GBA32**	M3.5*8	T-15	
STF-3225.2T.GBA32-120L	●	25	20	120		2				
STF-4032.3T.GBA32-150L	●	32	25	150		3				

STF Solt mills

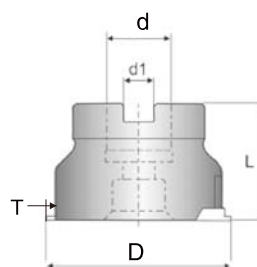

Ordering Code	Stock	Dimensions(mm)						Insert	Screw	Wrench
		D	d	H	T	Z				
STF-054.22.4T.GBA32	●	54	22	40	0.8-2.0	4	GBA32**	M3.5*8	T-15	
STF-063.22.5T.GBA32	●	63	22	40		5				
STF-080.27.6T.GBA32	●	80	27	50		6				
STF-100.32.8T.GBA33	●	100	32	50		8				

● Stock ○ Available upon Order

Turning inserts

External turning

Internal turning

Grooving & parting

Threading

Milling

Boring & drilling

Tool holder

Solid carbide end mills

Solid carbide drill & taps

Technical information

BBMS Mills

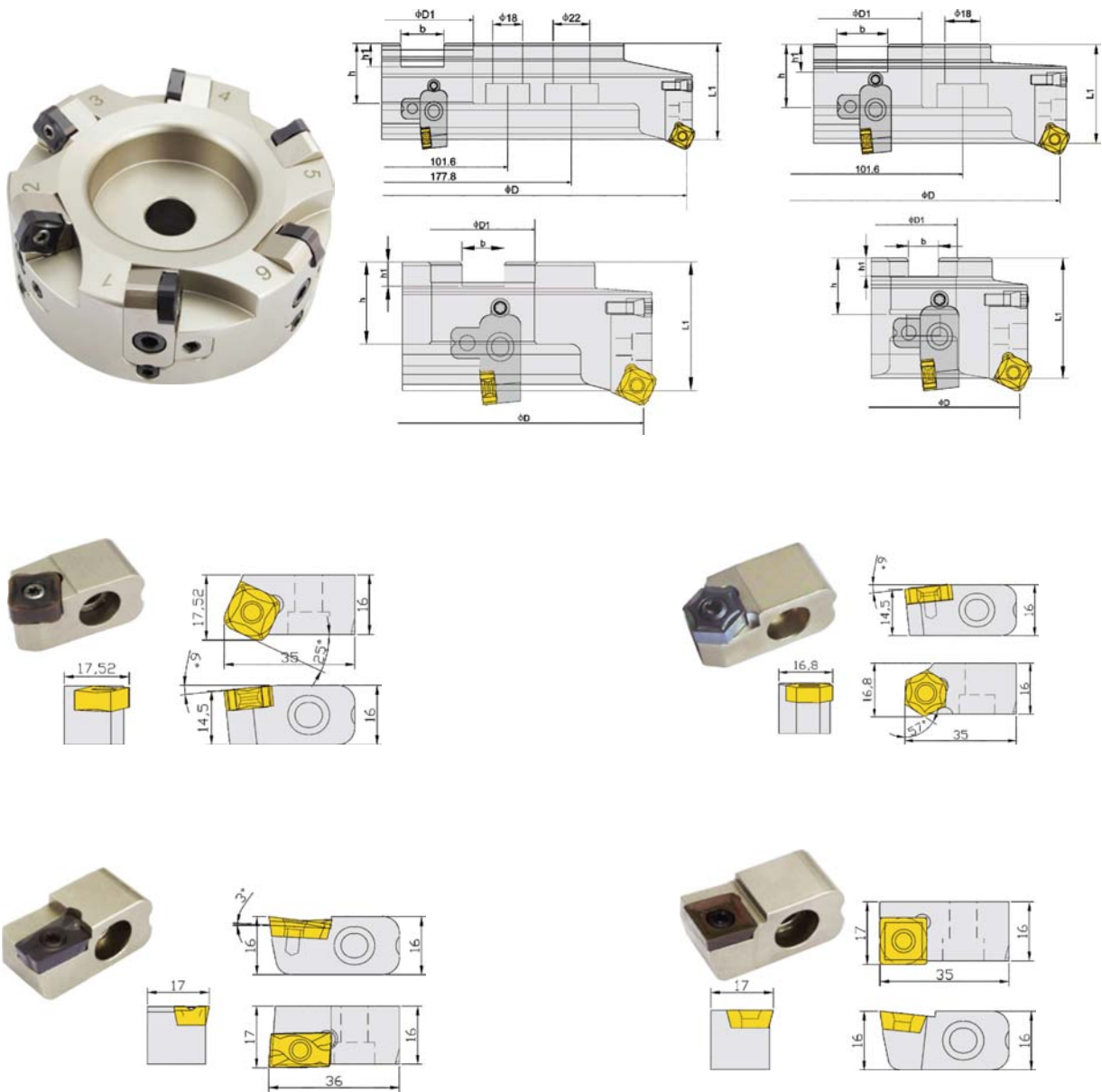

Ordering Code	Stock	Dimensions(mm)				Holder	Clamp	Insert	Screw	Wrench	Screw	Screw
		D	D1	L	Z							
BBMS.DP063.22.04T	●	63	22	50	4	DJ-SNMT	BYB1210	SNMT1205	M4*10	 L1.5 L3.0 L5.0 T-15	TJLS0510	DGD0620 ST0625
BBMS.DP080.27.05T	●	80	27	50	5							
BBMS.DP100.32.06T	●	100	32	50	6							
BBMS.DP125.40.08T	●	125	40	50	8							
BBMS.DP160.40.10T	●	160	40	50	10							
BBMS.DP200.60.12T	●	200	60	50	12							
BBMS.DP250.60.14T	●	250	60	50	14							
BBMS.DP315.60.16T	●	315	60	58	16							

● Stock ○ Available upon Order

Turning inserts

External turning

Internal turning

Grooving & parting

Threading

Milling

Boring & drilling

Tool holder

Solid carbide end mills

Solid carbide drill & taps

Technical information



Boring tools & drilling tools



<p>CKB*-TWN</p>  <p>P207</p>	<p>CKB*-EWN</p>  <p>P208</p>	<p>BT*-CKB*-TWN</p>  <p>P209~P210</p>	<p>BT*-CKB*-EWN</p>  <p>P211~P212</p>
<p>RDH-D*-L</p>  <p>P213</p>	<p>CDH-D*-L</p>  <p>P213</p>	<p>BJ*BE*A</p>  <p>P214</p>	<p>CDH-D*-L</p>  <p>P214</p>
<p>WBJ**</p>  <p>P215</p>	<p>WBJ**</p>  <p>P2115</p>	<p>EC*/ST*/BE*</p>  <p>P216</p>	<p>NBH*</p>  <p>P217</p>
<p>SBJ**</p>  <p>P217</p>	<p>BT*-NBH*-P</p>  <p>P217</p>	<p>SC*-CKB*-L</p>  <p>P218</p>	<p>BT*-CKB*</p>  <p>P219</p>
<p>Extension</p>  <p>P220</p>	<p>Extension</p>  <p>P220</p>	<p>BT*-DW*</p>  <p>P221</p>	<p>SPMG2D/3D/4D</p>  <p>P223~P225</p>
<p>WCMX2D/3D/4D</p>  <p>P226~P228</p>	<p>SPMG**</p>  <p>P229</p>	<p>WCMX-S</p>  <p>P229</p>	<p>Eccentric Sleeve</p>  <p>P230</p>

Turning inserts

External turning

Internal turning

Grooving & parting

Threading

Milling

Boring & drilling

Tool holder

Solid carbide end mills

Solid carbide drill & taps

Technical information

Two-Blade Rough Boring Head

《Boring Range from $\Phi 25$ – $\Phi 204$ mm》

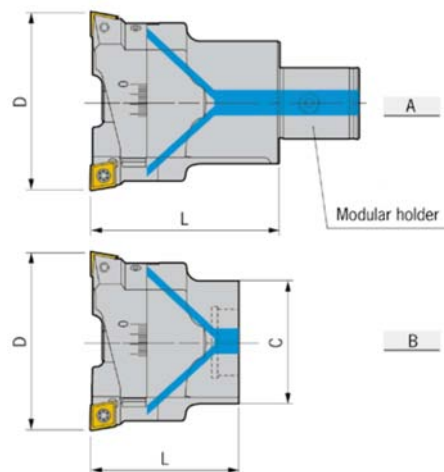

Ordering Code	Stock	D	C	L	Insert	Screw	Wrench	Cutter block	Clamp screw	Weight
CKB1-TWN2031-35	●	20-26	19	35	CC..0602..	M2.5X6.5	T7	TW20-26M	TW20TS	0.07
	●	25-31	19	35	CC..0602..	M2.5X6.5	T7	TW25-31M	TW20TS	0.12
CKB2-TWN3038-38	●	30-38	24	38	CC..0602..	M2.5X6.5	T7	TW30-38M	TW25TS	0.14
CBK3-TWN3747-43	●	37-47	31	43	CC..09T3..	M4X10	T15	TW37-47M	TW30TS	0.23
CBK4-TWN4659-50	●	46-59	39	50	CC..09T3..	M4X10	T15	TW46-47M	TW40TS	0.43
CBK5-TWN5875-60	●	58-75	50	60	CC..1204..	M5X13	T20	TW58-75M	TW50TS	0.82
CBK6-TWN7496-75	●	74-96	64	75	CC..1204..	M5X13	T20	TW74-96M	TW50TS	1.75
CKB6-TWN95122-75	●	95-122	64	75	CC..1204..	M5X13	T20	TW95-122M	TW50TS	2.35

Features:

1. Thickened cartridge with higher rigidity;
2. Coolant nozzle easily cools the insert, prolonging its working life;
3. Comitted with chip pocket, improving chipflow of deep boring;
4. Clamp plate solidifies cartridges and head, upgrading cutting rigidity.
5. Patented step boring design, suitable for both level boring and step boring.

● Stock ○ Available upon Order

EWN Micro-Finishing Boring Head

《Boring Range form $\Phi 25$ – $\Phi 204$ mm》

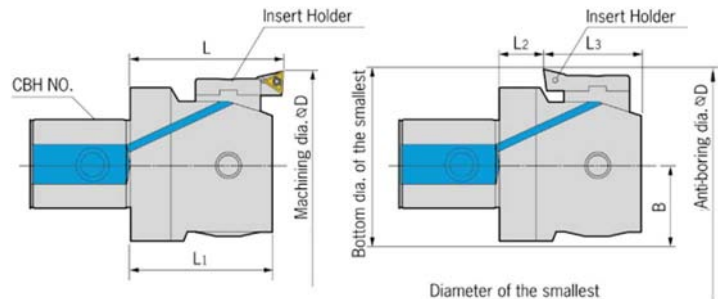

Ordering Code	Stock	dm	L	DC	Cutter block	Insert	Screw	Wrench	Weight
CKB1–EWN2031–32	●	19	32.5	20–26	ENH1–1	TP..0802	M2*5	T7	0.09
				25–31	ENH1–2				
CKB1–EWN2540–35	●	24	35.5	25–33	ENH1–1	TP..0902	M2.5*6	T8	0.13
				32–40	ENH1–2				
CKB2–EWN3045–35	●	31	40	30–38	ENH2–1	TP..0802	M2*5	T7	0.15
				37–45	ENH2–2				
CKB2–EWN3756–40	●	39	47	37–47	ENH3–1	TP..0802	M2*5	T7	0.25
				46–56	ENH3–2				
CKB4–EWN4671–47	●	50	57	46–59	ENH4–1	TP..1103	M3*8	T10	1.25
				58–71	ENH4–2				
CKB5–EWN5890–57	●	64	71	58–75	ENH5–1	TP..1103	M3*8	T10	1.78
				73–90	ENH5–2				
CKB16–EWN73130–71	●	71	71	75–96	ENH6–1	TP..1103	M3*8	T10	1.78
				98–130	ENH6–2				

1. There are pre-balanced design, availability and stability of the machining accuracy.
2. Standard corresponding to the anti-boring work processing, using a wide range of increasing added value.

	Tape	Stock	Fig	Boring head	Tape	Fig	Boring head
	ENH1–1	●	 TP08	EWN20–31	ENH4–1	 TC11 TP11	EWN46–71
	ENH1–2	●			ENH4–2		
	ENH2–1	●		EWN30–45	ENH5–1		EWN58–90
	ENH2–2	●			ENH5–2		
	ENH3–1	●		EWN37–56	ENH6–1		EWN73–130
ENH3–2	●	ENH6–2					

● Stock ○ Available upon Order

Turning inserts

External turning

Internal turning

Grooving & parting

Threading

Milling

Boring & drilling

Tool holder

Solid carbide end mills

Solid carbide drill & taps

Technical information

TWN Rough Boring Head

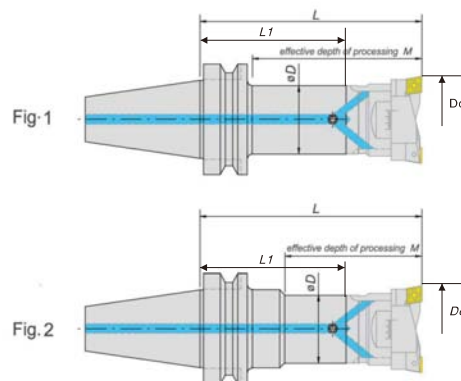

Ordering Code	Stock	Dc	YKL+TWN		PM	D	L	L1	Weight
BT30-CKB1TWN2026-81	●	20-26	BT30-CKB1-80	CKB1-TWN2026-35	81	19	115	80	0.48
BT30-CKB1TWN2531-81	●	25-31		CKB1-TWN2531-35	81	19	115	80	0.48
BT30-CKB2TWN3038-81	●	30-38	BT30-CKB2-80	CKB2-TWN3038-38	81	24	118	80	0.51
BT30-CKB3TWN3747-96	●	37-47	BT30-CKB3-80	CKB3-TWN3747-43	96	31	123	80	0.70
BT30-CKB4TWN4659-101	●	46-59	BT30-CKB4-80	CKB4-TWN4659-50	101	39	130	80	0.91
BT40-CKB1TWN2026-84	●	20-26	BT40-CKB1-85	CKB1-TWN2026-35	84	19	120	85	1.12
BT40-CKB1TWN2531-84	●	25-31		CKB1-TWN2531-35	84	19	120	85	1.15
BT40-CKB2TWN3038-87	●	30-38	BT40-CKB2-85	CKB2-TWN3038-38	87	24	123	85	1.21
BT40-CKB3TWN3747-111	●	37-47	BT40-CKB3-95	CKB3-TWN3747-43	111	31	138	95	1.32
BT40-CKB3TWN3747-123	●		BT40-CKB3-125		123	31	168	125	1.46
BT40-CKB4TWN4659-118	●	46-59	BT40-CKB4-95	CKB4-TWN4659-50	118	39	145	95	1.54
BT40-CKB4TWN4659-148	●		BT40-CKB4-125		148	39	170	125	1.86
BT40-CKB5TWN5875-128	●	58-75	BT40-CKB5-95	CKB5-TWN5875-60	128	50	155	95	1.81
BT40-CKB5TWN5875-158	●		BT40-CKB5-125		158	50	185	125	2.35
BT40-CKB6TWN7496-143	●	74-96	BT40-CKB6-95	CKB6-TWN7496-75	143	64	170	95	2.20
BT40-CKB6TWN7496-173	●		BT40-CKB6-125		173	64	200	125	3.05
BT40-CKB6TWN96122-143	●	96-122	BT40-CKB6-95	CKB6-TWN96122-75	143	64	170	95	2.20
BT40-CKB6TWN96122-173	●		BT40-CKB6-125		173	64	200	125	3.05

● Stock ○ Available upon Order

- Turning inserts
- External turning
- Internal turning
- Grooving & parting
- Threading
- Milling
- Boring & drilling
- Tool holder
- Solid carbide end mills
- Solid carbide drill & taps
- Technical information

TWN Rough Boring Head

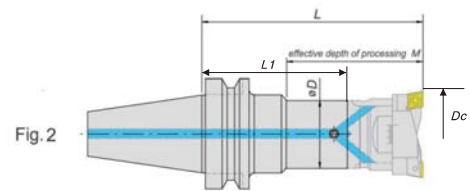
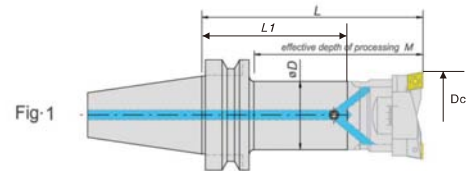

Ordering Code	Stock	Dc	YKL+TWN		PM	D	L	L1	Weight
BT50-CKB1TWN2026-102	●	20-26	BT50-CKB1-110	DKB31-TWN2026-35	102	19	145	110	3.92
BT50-CKB1TWN2531-102	●	25-31		DKB31-TWN2531-35	102	19	145	110	9.96
BT50-CKB2TWN3038-105	●	30-38	BT50-CKB2-110	DKB32-TWN3038-38	105	24	148	110	4.06
BT50-CKB3TWN3747-118	●	37-47	BT50-CKB3-125	DKB33-TWN3747-43	118	31	168	125	4.28
BT50-CKB3TWN3747-133	●		BT50-CKB3-165		133	31	208	165	4.39
BT50-CKB4TWN4659-132	●	46-59	BT50-CKB4-125	DKB34-TWN4659-50	132	39	175	125	4.61
BT50-CKB4TWN4659-145	●		BT50-CKB4-165		145	39	215	165	4.81
BT50-CKB5TWN5875-147	●	58-75	BT50-CKB5-125	DKB35-TWN5875-60	147	50	175	125	4.73
BT50-CKB5TWN5875-187	●		BT50-CKB5-165		187	50	225	165	5.17
BT50-CKB6TWN7496-162	●	74-96	BT50-CKB6-125	Cx36-TWN7496-75	162	64	200	125	5.26
BT50-CKB6TWN7496-202	●		BT50-CKB6-165		202	64	240	165	6.02
BT50-CKB6TWN7496-242	●		BT50-CKB6-205		242	64	280	205	6.78
BT50-CKB6TWN95122-162	●	75-122	BT50-CKB6-125	Cx36-TWN95122-75	162	64	200	125	5.26
BT50-CKB6TWN95122-202	●		BT50-CKB6-165		202	64	240	165	6.02
BT50-CKB6TWN95122-242	●		BT50-CKB6-205		242	64	280	205	6.78

● Stock ○ Available upon Order

Turning inserts

External turning

Internal turning

Grooving & parting

Threading

Milling

Boring & drilling

Tool holder

Solid carbide end mills

Solid carbide drill & taps

Technical information

EWN Micro-Finishing Boring Head

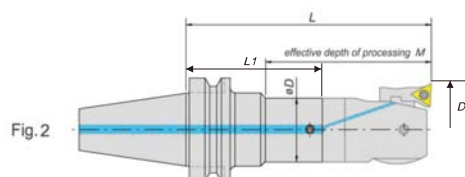
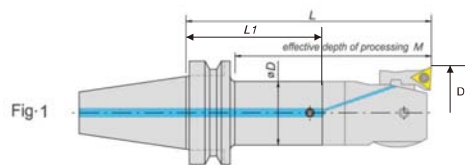

Ordering Code	Stock	Dc	CKB+EWN		M	D	L	L1	Weight
BT30-CKB1EWN2031-78	●	20-31	BT30-CKB1-80	CKB1-EWN2031-32.5	78	19	112.5	80	0.56
BT30-CKB1EWN2536-78	●	25-36		CKB1-EWN2536-32.5	78	19	112.5	80	0.56
BT30-CKB2EWN3045-81	●	30-45	BT30-CKB2-80	CKB2-EWN3045-35	81	24	115	80	0.60
BT30-CKB3EWN3756-98	●	37-56	BT30-CKB3-80	CKB3-EWN3756-40	98	31	120	80	0.76
BT30-CKB4EWN4671-105	●	46-71	BT30-CKB4-80	CKB4-EWN4671-47	105	39	127	80	1.05
BT40-CKB1EWN2031-82	●	20-31	BT40-CKB1-85	CKB1-EWN2031-32.5	82	19	117.5	85	1.19
BT40-CKB1EWN2536-82	●	25-36		CKB1-EWN2536-32.5	82	19	117.5	85	1.19
BT40-CKB2EWN3045-84	●	30-45	BT40-CKB2-85	CKB2-EWN3045-35	84	24	120	85	1.28
BT40-CKB3EWN3756-108	●	37-56	BT40-CKB3-95	CKB3-EWN3756-40	108	31	135	95	1.38
BT40-CKB3EWN3756-120	●		BT40-CKB3-125		120	31	155	125	1.51
BT40-CKB4EWN4671-115	●	46-71	BT40-CKB4-95	CKB4-EWN4671-47	115	39	142	95	1.62
BT40-CKB4EWN4671-145	●		BT40-CKB4-125		145	39	172	135	1.97
BT40-CKB5EWN5890-125	●	58-90	BT40-CKB5-95	CKB5-EWN5890-57	125	50	152	95	1.92
BT40-CKB5EWN5890-155	●		BT40-CKB5-125		155	50	182	135	2.48
BT40-CKB6EWN73130-147	●	73-130	BT40-CKB6-95	CKB6-EWN73130-71	147	64	166	95	2.32
BT40-CKB6EWN73130-177	●		BT40-CKB6-125		177	64	196	135	3.18

● Stock ○ Available upon Order

- Turning inserts
- External turning
- Internal turning
- Grooving & parting
- Threading
- Milling
- Boring & drilling
- Tool holder
- Solid carbide end mills
- Solid carbide drill & taps
- Technical information

EWN Micro-Finishing Boring Bar

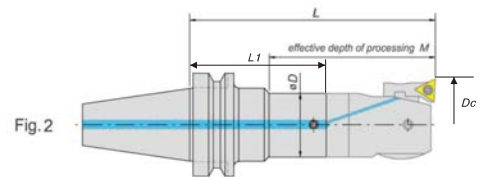
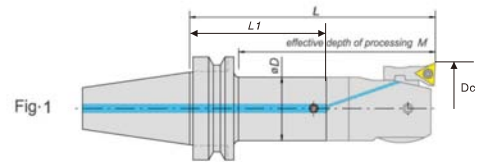

Ordering Code	Stock	Dc	CKB+EWN		PM	D	L	L1	Weight
BT50-CKB1EWN2031-100	●	20-31	BT50-CKB1-110	CKB1-EWN2031-32.5	100	19	142.5	110	4.05
BT50-CKB1EWN2536-100	●	25-36		CKB1-EWN2536-32.5	100	19	142.5	110	4.05
BT50-CKB2EWN3045-102	●	30-45	BT50-CKB2-110	CKB2-EWN3045-35.5	102	24	145.5	110	4.15
BT50-CKB3EWN3756-115	●	37-56	BT50-CKB3-125	CKB3-EWN3756-40	115	31	165	125	4.38
BT50-CKB3EWN3756-130	●		BT50-CKB3-165		130	31	205	165	4.50
BT50-CKB4EWN4671-129	●	46-71	BT50-CKB4-125	CKB4-EWN4671-47	129	39	172	125	4.75
BT50-CKB4EWN4671-144	●		BT50-CKB4-165		144	39	212	165	4.93
BT50-CKB5EWN5890-139	●	58-90	BT50-CKB5-125	CKB5-EWN5890-57	139	50	182	125	4.85
BT50-CKB5EWN5890-154	●		BT50-CKB5-165		154	50	222	165	5.27
BT50-CKB6EWN73130-158	●	73-130	BT50-CKB6-125	CKB6-EWN73130-71	158	64	196	125	5.35
BT50-CKB6EWN73130-198	●		BT50-CKB6-165		198	64	236	165	6.21
BT50-CKB6EWN73130-238	●		BT50-CKB6-205		238	64	276	205	6.91

● Stock ○ Available upon Order

Turning inserts

External turning

Internal turning

Grooving & parting

Threading

Milling

Boring & drilling

Tool holder

Solid carbide end mills

Solid carbide drill & taps

Technical information

Turning inserts

External turning

Internal turning

Grooving & parting

Threading

Milling

Boring & drilling

Tool holder

Solid carbide end mills

Solid carbide drill & taps

Technical information

Indexable Two-blade Rough Boring Head

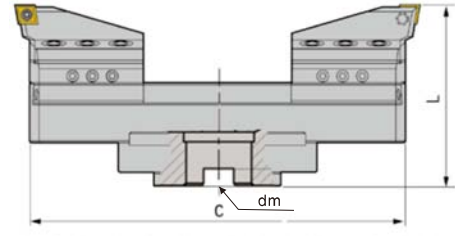

Ordering Code	Stock	dm	L	C	Insert	Cutter block	Extension Side	Clamp	Screw	Screw	Wrench	Weight
RDH-D122-152-80L	●	32	84	122-152	CC..1204	RDH-CC12	HB122-152	RDH-HK	NLJ-M8	M5*13	T20	3
RDH-D151-211-80L	●			151-211								5
RDH-D210-290-80L	●			210-290								5.9
RDH-D290-370-80L	●			290-370								6.8
RDH-D370-450-80L	●			370-450								7.8
RDH-D450-550-80L	●			450-550								8.8
RDH-D550-650-80L	○			550-650								9.9
RDH-D650-750-80L	○			650-750								10.9

Indexable Two-blade Rough Boring Head

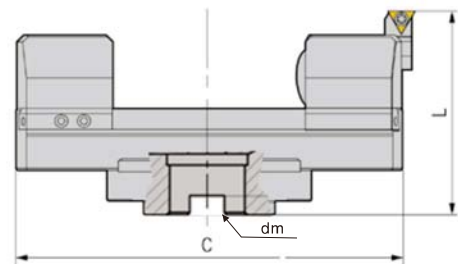

Ordering Code	Stock	dm	L	C	Insert	Boring	Clamp weight	Extension Side	Screw	Screw	Wrench	Weight
CDH-D122-152-84L	●	32	84	122-152	TP..0902	CDH-TT	CDH-PHK	HB122-152	NLJ-M8	M5*13	T20	3
CDH-D151-211-84L	●			151-211								4.8
CDH-D210-290-84L	●			210-290								5.2
CDH-D290-370-84L	●			290-370								6.1
CDH-D370-450-84L	●			370-450								7
CDH-D450-550-84L	●			450-550								8
CDH-D550-650-84L	●			550-650								9
CDH-D650-750-84L	●			650-750								10

● Stock ○ Available upon Order

Outside diameter boring series

S type Processing range: $\Phi 0.5 \sim \Phi 27$

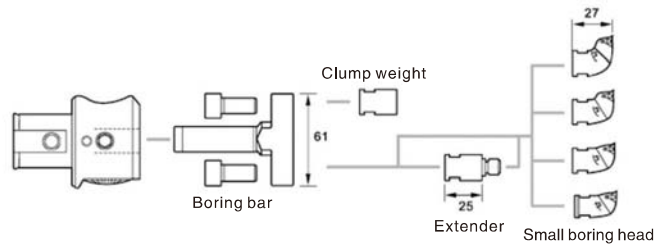

	Ordering Code	Stock	Processing diameter Φd	EW boring head	Boring bar	Clump weight	Extender	Small boring head	Blade
	BJ16BE36A	<input type="radio"/>	0.5-9	WBH2-50LBK6 (1.05Kg)	ST16-SL27-55 (0.20Kg)	BW-M10 (0.02Kg)	M1010-25 (0.02Kg)	BE36A	TP08
	BJ16BE28A	<input type="radio"/>	9-17					BE28A	
	BJ16BE22A	<input type="radio"/>	17-23					BE22A	
	BJ16BE18A	<input type="radio"/>	23-27					BE18A	
<p>1. The maximum, minimum diameter of processing is the use of nose radius R0.2 insert value; 2. Without blade, please order; 3. The processing, the spindle should be reversed; 4. Please note the eccentric changes when the interference range will also change.</p>									

Outside diameter boring series

L type Processing range: $\Phi 21 \sim \Phi 662$

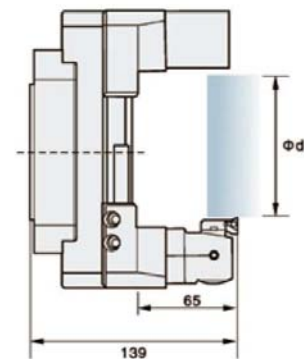

Ordering Code	Stock	dm	L	D	Insert	Boring	Clump weight	Clamp	Screw	Screw	Wrench	Weight
CDH-D8-55-78L	<input checked="" type="radio"/>	32	84	8-55	TP..1103	CKB4-EWN4671	CKB4-PHK	CDH-CKB4	NLJ-M8	M5*13	T20	3
CDH-D30-120-78L	<input checked="" type="radio"/>			30-120								4.8

1. The maximum, minimum diameter of processing is the use of tool nose radius R0.4 insert value;
2. WBH boring head with 1 blade holder (ENF4-1), but not with the blade, please order;
3. The processing, the spindle should be reversed;
4. The use of FL135, FL200 nose direction and drive health direction and please, when using the FL135/90, FL200/90 tip direction and perpendicular to the direction of transmission key.

Stock Available upon Order

WBJ16 Fine-tune Precision Boring Tools

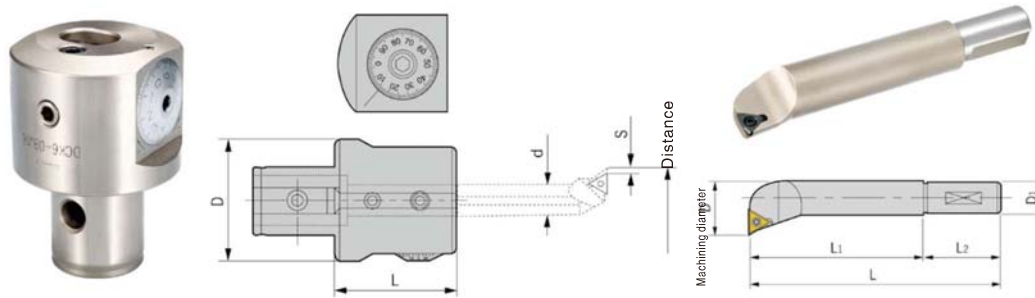

Ordering Code	Stock	Boring Range	D	d	L	Tuning precision	Stroke	Weight(Kg)
WBJ16	●	Φ6-Φ50	63	16	50	Φ0.01mm	6.0mm	1.2

Ordering Code	Stock	Boring Range	D1	L1	L	Applicable Insert	Clamp Screw	Spanner	Weight(Kg)
WBJ-1606-24	○	6-9	16	24	73	WBGT0601...L	M2x4	T6	0.014
WBJ-1608-32	●	8-11		32	80	TBGT0601...L	M2x5		0.077
WBJ-1610-40	●	10-13		40	87				0.082
WBJ-1612-53	●	12-17		53	98	TPGH0902...L	M2.5x6	T8	0.095
WBJ-1616-53	●	16-21		68	110				0.143
WBJ-1620-83	●	20-26		83	125				0.203
WBJ-1625-90	●	25-31		90	128	TPGH1103...L	M3.0x7	T8	0.275
WBJ-1630-90	●	30-42		90	128				0.275
WBJ-1640-90	●	40-50		90	128				0.286

WBJ16 Fine-tune Precision Boring Tools(8PCS)

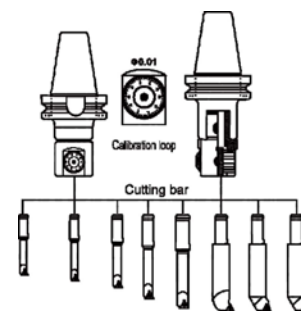

Ordering Code	Stock	Boring Range	Spinde Handle Model	Head NO.	Bar Keep Out	Weight(Kg)
BT40-WBJ16-8P	●	8-50	BT40-LBK6-55	16	WBJ-16..	9.1
BT50-WBJ16-8P	●	8-50	BT50-LBK6-65		WBJ-16..	11.7
NT40-WBJ16-8P	●	8-50	NT40-LBK6-55		WBJ-16..	8.5
NT50-WBJ16-8P	●	8-50	NT50-LBK6-55		WBJ-16..	10.3
SK40-WBJ16-8P	●	8-50	SK40-LBK6-55		WBJ-16..	6.9
SK50-WBJ16-8P	●	8-50	SK50-LBK6-65		WBJ-16..	10.5

● Stock ○ Available upon Order

Collet for Tungsten Carbide Small Diameter Modular Boring Bar Series Type EC

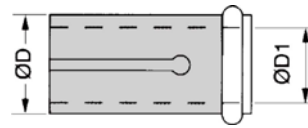

Ordering Code	Stock	D(mm)	d1(mm)	Applicable Carbide Tool Holder
EC1608	○	16	8	ST08.HC08
EC1610	○	16	10	ST10.HC10
EC1612	○	16	12	ST12.HC12
EC1614	○	16	14	St14

Tungsten Carbide Small Diameter Modular Boring Bar,ST Type

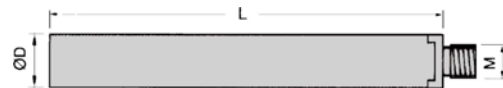

Ordering Code	Stock	L(mm)	D(mm)	M(mm)	Applicable Carbide Tool Holder	Applicable Bushing
ST08-W5-100L	●	100	8	M5	BE09A.BE10.5A	EC1608
ST10-W6-110L	●	110	10	M6	BE12A	EC1610
ST12-W6-120L	●	120	12		BE14A.BE16A	EC1612
ST14-W6-160L	●	160	14		BE16A	EC1614
ST16-W10-160L	●	160	16	M10	BE18A BE20A BE22A BE24A BE26A BE28A BE30A BE32A BE34A BE36A BE38A BE40A	-

Boring Head, BE Type 《Boring Range Φ9-Φ50mm》

	Ordering Code	Stock	d(mm)	H(mm)	L(mm)	M(mm)	Insert	Clamp Screw	Wrench
	BE09A	●	9	7	18	M5	TP..0802..	M2.2	T7
	BE10.5A	●	10.5						
	BE12A	●	12	10	23	M6			
	BE14A	●	14						
	BE16A	●	16						
	BE18A	●	18						
	BE20A	●	20	14	27	M10			
	BE22A	●	22						
	BE24A	●	24						
	BE26A	●	26						
	BE28A	●	28						
	BE30A	●	30						
	BE32A	●	32						
	BE34A	●	34						
	BE36A	●	36						
	BE38A	●	38						
BE40A	●	40							

● Stock ○ Available upon Order

Turning inserts

External turning

Internal turning

Grooving & parting

Threading

Milling

Boring & drilling

Tool holder

Solid carbide end mills

Solid carbide drill & taps

Technical information

NBH2084 Fine-tune Precision Boring Tools

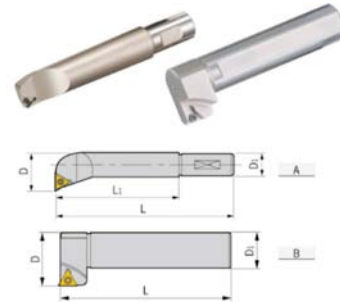
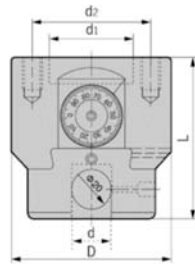

Ordering Code	Stock	D	d	d1	d2	L	Boring Range	Tuning precision	Stroke	Weight(Kg)
NBH2084	●	84	20	35	60	80	Φ8-Φ280	Φ0.01mm	28.0mm	3.0

Ordering Code	Stock	Boring Range	D1	L1	L	Applicable Inserts	Clamp Screw	Spanner	Weight(Kg)
SBJ-2008-32	●	8-11	20	32	80	TBGT0601..L	M2.0x5	T6	0.095
SBJ2010-40	●	10-13		40	87				0.095
SBJ2012-53	●	12-17		53	98	TPGH0902..L	M2.5x6	T8	0.12
SBJ2016-68	●	16-21		68	110				0.16
SBJ2020-83	●	20-130		83	123	TPGH1103..L	M3.0x7	T8	0.22
SBJ2025-96	●	25-135		96	137				0.34
SBJ2030-115	●	30-140		115	152				0.54
SBJ2020-L	●	120-280		84+BTL1	100				0.23

NBH2084 Fine-tune Precision Boring Tools(Set)

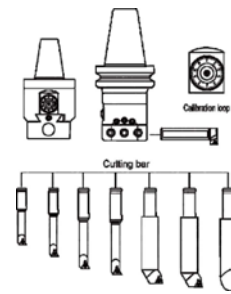

Ordering Code	Stock	Boring Range	Spinde Handle Model	Head NO.	Bar Keep Out	Weight(Kg)
BT40-NBH2084-8P	●	08-280	BT40-NBH-50	NBH2084	SBJ-20..	9.5
BT50-NBH2084-8P	●	08-280	BT50-NBH-55		SBJ-20..	12.0
NT40-NBH2084-8P	●	08-280	NT40-NBH-50		SBJ-20..	9.3
NT50-NBH2084-8P	●	08-280	NT50-NBH-55		SBJ-20..	10.8
SK40-NBH2084-8P	●	08-280	SK40-NBH-50		SBJ-20..	9.5
SK50-NBH2084-8P	●	08-280	SK50-NBH-55		SBJ-20..	12.0
R8-NBH-2084-8P	●	08-280	R8-NBH-50		SBJ-20..	10.0

● Stock ○ Available upon Order

Turning inserts

External turning

Internal turning

Grooving & parting

Threading

Milling

Boring & drilling

Tool holder

Solid carbide end mills

Solid carbide drill & taps

Technical information

Super Hard Solid Tungsten Carbide Boring Bar

《Boring Range form $\Phi 20$ – $\Phi 75$ mm》

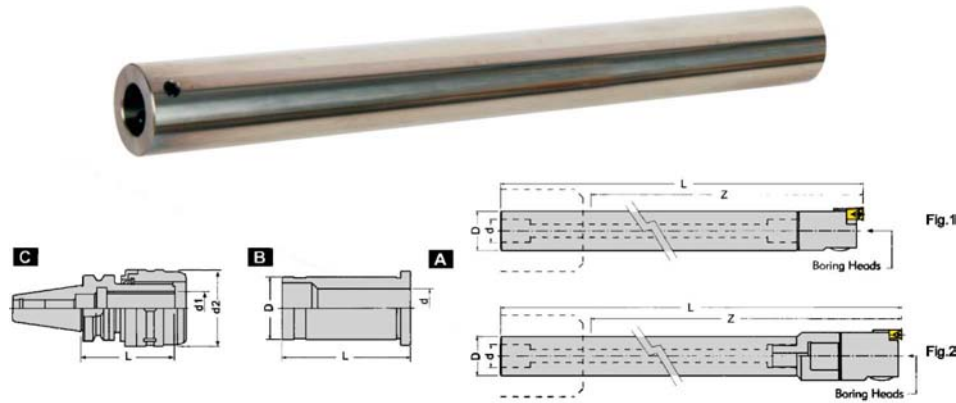

Ordering Code	Stock	Fig	Φ dmm Internal Dia.	Dmm External Dia.	L(mm)	Z(mm)	Applicable Boring Heads	Weight (Kg)
SC19-CKB1-150L	●	1	11	19	225	150	CKB1	0.8
SC19-CKB1-200L	●				275	200	CKB1	1
SC24-CKB2-180L	●		14	24	260	180	CKB2	1.45
SC24-CKB2-240L	●				320	240	CKB2	1.8
SC32-CKB3-240L	●	2	18	32	320	240	CKB3	2.8
SC32-CKB3-310L	●				390	310	CKB3	3.2
SC32-CKB3-280L	●	2	18	32	365	280	CKB3	3.1
SC32-CKB4-280L	●				22	39	365	280
SC32-CKB3-350L	●	2	18	32	435	350	CKB3	3.8
SC32-CKB4-350L	●				22	39	435	350
SC40-CKB4-310L	●	1	22	40	390	310	CKB4	5
SC40-CKB4-400L	●				480	400	CKB4	6.5
SC40-CKB4-360L	●	2	22	40	445	360	CKB4	5.6
SC40-CKB5-360L	●				28	50	445	360
SC40-CKB4-450L	●	2	22	40	535	450	CKB4	7.1
SC40-CKB5-450L	●				28	50	535	450

1. Super hard tungsten carbide boring bar made from high toughness compound is tough and durable, highly materializing features of super hardness, high rigidity and extra vibration resistance, most suitable for extra depth boring (10D);
2. Standard internal coolant hole is built in every size of the bar, best for cooling and chip evacuation in deep hole boring;
3. Featuring straight shank structure, the bar can be adjusted to different working lengths;
4. On both ends of main body integrated are soldering holes. One hole will be superseded by the other upon breaking. This will reduce your cost greatly increase the value of boring car.

★ Boring head is not included

★ CKB3/4 and CKB4/5 are extensions with magnifying diameter

● Stock ○ Available upon Order

Turning inserts

External turning

Internal turning

Grooving & parting

Threading

Milling

Boring & drilling

Tool holder

Solid carbide end mills

Solid carbide drill & taps

Technical information

LBK Boring Holder

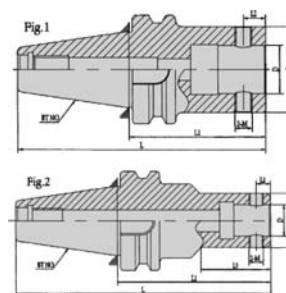

Ordering Code	Stock	Type	L	L2	D	d	D1	G	Weight	
BT30-CKB1-80	●	Fig.1	80	46	19	11	31	M4x0.5	0.75	
BT30-CKB2-80	●		80	46	24	14	31	M5x0.5	0.83	
BT30-CKB3-80	●		80	58	31	18	31	M6x0.75	0.91	
BT30-CKB4-80	●		80	58	39	22	39	M8x0.75	1.02	
BT40-CKB1-85	●		85	49	19	11	31	M4x0.5	1.18	
BT40-CKB1-115	●		115	79	19	11	31	M4x0.5	1.21	
BT40-CKB2-85	●		85	49	24	14	31	M5x0.5	1.21	
BT40-CKB2-115	●		115	79	24	14	31	M5x0.5	1.27	
BT40-CKB3-95	●		95	68	31	18	31	M6x0.75	1.32	
BT40-CKB3-125	●		125	80	31	18	37	M6x0.75	1.46	
BT40-CKB3-155	●		Fig.2	155	85	31	18	37	M6x0.75	1.62
BT40-CKB4-95	●		Fig.1	95	68	39	22	39	M8x0.75	1.54
BT40-CKB4-125	●	125		98	39	22	39	M8x0.75	1.86	
BT40-CKB4-155	●	Fig.2	155	128	39	22	46	M8x0.75	2.15	
BT40-CKB4-185	●		185	120	39	22	46	M8x0.75	2.42	
BT40-CKB5-95	●	Fig.1	95	68	49	28	49	M10x1	1.81	
BT40-CKB5-125	●		125	98	49	28	49	M10x1	2.35	
BT40-CKB5-155	●		155	128	49	28	49	M10x1	2.75	
BT40-CKB5-185	●		185	155	49	28	49	M10x1	3.05	
BT40-CKB6-95	●		95	68	63	36	63	M12x1	2.75	
BT40-CKB6-125	●		125	98	63	36	63	M12x1	3.20	
BT40-CKB6-155	●		155	128	63	36	63	M12x1	3.40	
BT40-CKB6-185	●		185	158	63	36	63	M12x1	3.60	
BT50-CKB1-110	●		110	67	19	11	27	M4x0.5	3.93	
BT50-CKB1-145	●	Fig.2	145	75	19	11	27	M4x0.5	4.05	
BT50-CKB2-110	●	Fig.1	110	67	24	14	31	M5x0.5	4.08	
BT50-CKB2-145	●	Fig.2	145	75	24	14	35	M5x0.5	4.20	
BT50-CKB3-125	●	Fig.1	125	75	31	18	36	M6x0.75	4.10	
BT50-CKB3-165	●	Fig.2	165	90	31	18	36	M6x0.75	4.35	
BT50-CKB4-125	●	Fig.1	125	82	39	22	45	M8x0.75	4.35	
BT50-CKB4-165	●		165	95	39	22	45	M8x0.75	4.70	
BT50-CKB4-205	●	Fig.2	205	110	39	22	45	M8x0.75	5.02	
BT50-CKB5-125	●	Fig.1	125	82	49	28	49	M10x1	4.75	
BT50-CKB5-165	●		165	95	49	28	58	M10x1	5.20	
BT50-CKB5-205	●	Fig.2	205	110	49	28	58	M10x1	5.53	
BT50-CKB5-245	●		245	150	49	28	58	M10x1	5.95	
BT50-CKB6-125	●	Fig.1	125	87	63	36	73	M12x1	5.15	
BT50-CKB6-165	●		165	127	63	36	73	M12x1	6.10	
BT50-CKB6-205	●	Fig.2	205	165	63	36	73	M12x1	7.40	
BT50-CKB6-245	●		245	150	63	36	73	M12x1	7.75	
BT50-CKB6-285	●		285	185	63	36	73	M12x1	8.10	

● Stock ○ Available upon Order

Extension(Constant Diameter)

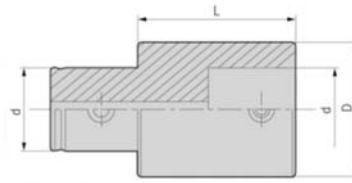

Ordering Code	Stock	d (mm)	D (mm)	L (mm)	Applicable Boring Heads	Weight (Kg)
CKB1-1-30L	●	11	19	30	CKB1	0.07
CKB2-2-30L	●	14	24	30	CKB2	0.1
CKB3-3-30L	●	18	31	30	CKB3	0.15
CKB4-4-45L	●	22	39	45	CKB4	0.4
CKB5-5-60L	●	28	50	60	CKB5	0.8
CKB6-6-60L	●	36	64	60	CKB6	1.4

Extension(Reducing)

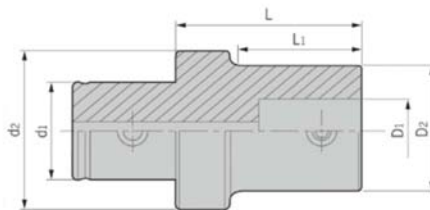

Ordering Code	Stock	d1 (mm)	d2 (mm)	D1 (mm)	D2 (mm)	L (mm)	L1 (mm)	Applicable Boring Heads	Weight (Kg)
CKB2-1-36L	●	14	24	14	24	36	30	CKB2/CKB1	0.1
CKB3-1-41L	●	18	31	14	24	41	30	CKB3/CKB1	0.15
CKB3-2-37L	●			11	19	37	25	CKB3/CKB2	0.15
CKB4-1-58L	●	22	39	14	24	58	40	CKB4/CKB1	0.3
CKB4-2-50L	●			18	31	50	36	CKB4/CKB2	0.3
CKB4-3-50L	●			22	39	50	37	CKB4/CKB3	0.35
CKB5-1-60L	●	28	50	11	19	60	40	CKB5/CKB1	0.45
CKB5-2-54L	●			14	24	54	35	CKB5/CKB2	0.45
CKB5-2-74L	●			14	24	74	55	CKB5/CKB2	0.5
CKB5-3-47L	●			18	31	47	29	CKB5/CKB3	0.5
CKB5-3-72L	●			18	31	72	54	CKB5/CKB3	0.6
CKB5-4-42L	●			22	39	42	25	CKB5/CKB4	0.5
CKB5-4-67L	●			22	39	67	50	CKB5/CKB4	0.7
CKB6-1-70L	●	36	64	11	19	70	40	CKB6/CKB1	0.9
CKB6-2-63L	●			14	24	63	45	CKB6/CKB2	0.7
CKB6-2-93L	●			14	24	93	75	CKB6/CKB2	0.8
CKB6-3-56L	●			18	31	56	39	CKB6/CKB3	0.75
CKB6-3-96L	●			18	31	96	79	CKB6/CKB3	0.95
CKB6-4-51L	●			22	39	51	35	CKB6/CKB4	0.85
CKB6-4-101L	●			22	39	101	85	CKB6/CKB4	1.3
CKB6-5-41L	●			36	64	41	25	CKB6/CKB5	0.85
CKB6-5-91L	●			36	64	91	75	CKB6/CKB5	1.45

● Stock ○ Available upon Order

Turning inserts

External turning

Internal turning

Grooving & parting

Threading

Milling

Boring & drilling

Tool holder

Solid carbide end mills

Solid carbide drill & taps

Technical information

Turning inserts

External turning

Internal turning

Grooving & parting

Threading

Milling

Boring & drilling

Tool holder

Solid carbide end mills

Solid carbide drill & taps

Technical information

Large Size Boring Bar BT NO-DM-L1

- BT NO taper shank executives At3 standard;
- Tolerance for D inner bore;
- Entire center cooling is good for through coolant and antivibration.

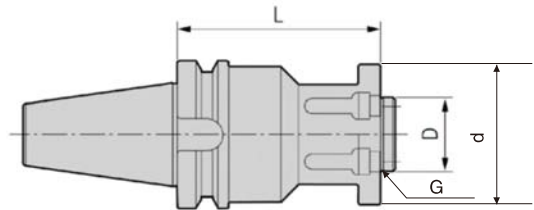

Ordering Code	Stock	L	D	d	G	Weight
BT40-DM32-60	●	60	100	32	4-M12	2.42
BT50-DM32-100	●	100	100	32	4-M12	6.3
BT50-DM32-150	●	150	100	32	4-M12	9.2
BT50-DM32-200	●	200	100	32	4-M12	11.1
BT50-DM32-250	●	250	100	32	4-M12	12.9
BT50-DM32-300	●	300	100	32	4-M12	14.8

● Stock ○ Available upon Order

TWN Twin-bit Rough Boring Head Operating Guide Line

- ① Boring body
- ② Insert holder
- ③ Insert screw
- ④ Insert
- ⑤ Locking screw
- ⑥ Adjusting screw

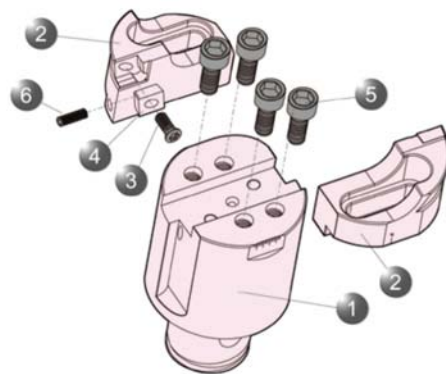

- Step 1: Clockwise (Locking)
- Step 3: Anticlockwise (Loosening)
- Step 2
- Step 4

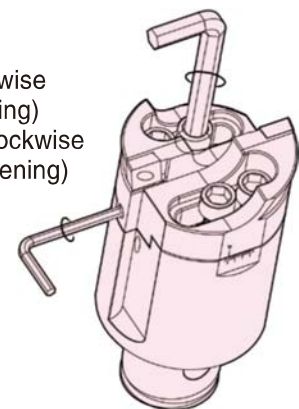

Sequence Of Use

Please operate the following step(1-6) according to the diagram figured:

Step1. Loosening the fixed screws on the blade bearing.

Step2. Rotating and adjusting the side screws to move the blade bearing to an scheduled processing dimension.

Step3. Locking the fixed screws on the blade bearing.

Step4. Using proper force to rotate and adjust the screws to avoid the screw loose during cutting.

EWN16 Fine-tune Precision Boring Operating manual

- ① CBH adapter
- ② Micro adjusting knob
- ③ CBH body
- ④ Insert holder
- ⑤ Locking screw
- ⑥ Oil hole

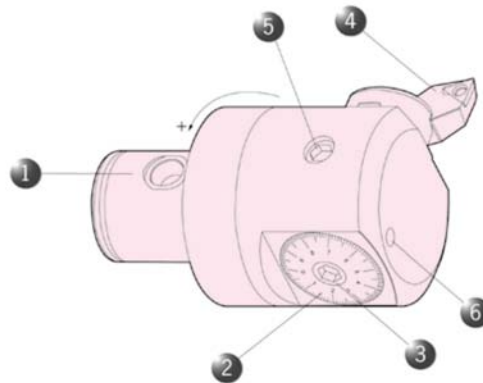

Sequence Of Use

Please operate the following step(1–5)according to the diagram figured:

Step1.Loosening the locking screws.

Step2.Rotating tune knob by clockwise to increase the processing diameter,the graduate is $\Phi 0.01\text{mm}$.

Step3.Rotating by anti-clockwise will decrease the processing diameter.

Step4.When adjusting the size of processing,please fine-tuning by the direction to ensure mirco adjustment precision.

Step5.When meet the demanded size,please use proper force to lock the fasten screws.

WBJ16 Fine-tune Precision Boring Operating manual

- ① DBJ16 adapter
- ② Micro adjusting knob
- ③ Insert
- ④ DBJ16 body
- ⑤ Locking screw

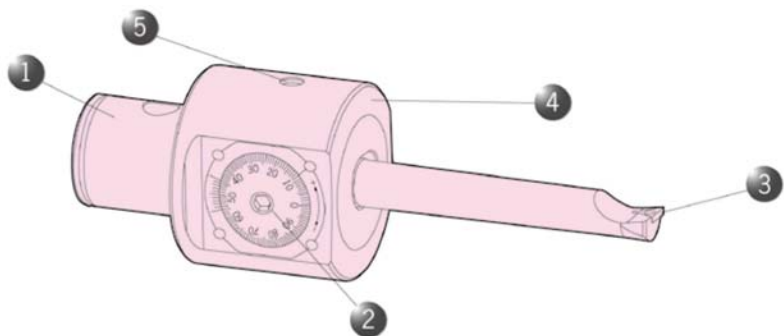

Sequence Of Use

Please operate the following step(1–6)according to the diagram figured:

Step1.Using special wrench to lock two M10 screws to fasten the cutting tools in the processing size range.

Step2.Loosening the fixed screws.

Step3.Rotating tune knob by clockwise to increase the processing diameter,the graduate is $\Phi 0.01\text{mm}$.

Step4.Rotating by anti-clockwise will decrease the processing diameter.

Step5.When adjusting the size of processing,please fine-tuning by the same dircetion to ensure mirco adjustment precision.

Step6.When meet the demanded size,please use the proper force to lock the spindle orientation to makespindle fix into the substance.

SPMG2D Fast Drilling(U Drill)

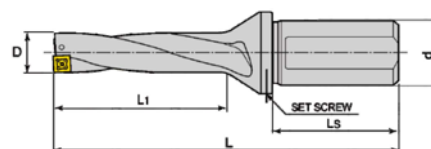

Ordering Code	Stock	D (mm)	L1 (mm)	L (mm)	d (mm)	LS (mm)	Insert	Screw	Wrench
C20-2D13-29SP05	●	13	29	88	20	50	SPMG050204	M2	T6
C20-2D13.5-30SP05	●	13.5	30	89					
C20-2D14-31SP05	●	14	31	90					
C20-2D14.5-32SP05	●	14.5	32	91					
C20-2D15-33SP05	●	15	33	92					
C20-2D15.5-34SP06	●	15.5	34	93					
C20-2D16-35SP06	●	16	35	94					
C20-2D16.5-36SP06	●	16.5	36	95					
C25-2D17-37SP06	●	17	37	108					
C25-3D17.5-38SP06	●	17.5	38	109					
C25-2D18-39SP06	●	18	39	110	25	56	SPMG060204	M2.2	T6
C25-2D18.5-40SP06	●	18.5	40	111					
C25-2D19-41SP06	●	19	41	112					
C25-2D19.5-42SP06	●	19.5	42	113					
C25-2D20-43SP06	●	20	43	114					
C25-2D20.5-44SP06	●	20.5	44	115					
C25-2D21-45SP06	●	21	45	116					
C25-2D21.5-46SP06	●	21.5	46	117					
C25-2D22-47SP07	●	22	47	118					
C25-2D22.5-48SP07	●	22.5	48	119					
C25-2D23-49SP07	●	23	49	123	32	60	SPMG07T38	M2.5	T8
C25-2D23.5-50SP07	●	23.5	50	124					
C25-2D24-51SP07	●	24	51	125					
C25-2D24.5-52SP07	●	24.5	52	126					
C25-2D25-53SP07	●	25	53	127					
C32-2D25.5-54SP07	●	25.5	54	134					
C32-2D26-55SP07	●	26	55	135					
C32-2D26.5-56SP07	●	26.5	56	136					
C32-2D27-57SP07	●	27	57	137					
C32-2D27.5-58SP07	●	27.5	58	138					
C32-2D28-59SP09	●	28	59	139	40	70	SPMG090408	M3.5	T15
C32-2D28.5-60SP09	●	28.5	60	140					
C32-2D29-62SP09	●	29	62	143					
C32-2D29.5-63SP09	●	29.5	63	144					
C32-2D30-64SP09	●	30	64	148					
C32-2D31-66SP09	●	31	66	150					
C32-2D32-68SP09	●	32	68	152					
C32-2D33-70SP09	●	33	70	154					
C32-2D34-72SP11	●	34	72	156					
C32-2D35-74SP11	●	35	74	158					
C32-2D36-76SP11	●	36	76	160	40	70	SPMG110408	M4M	T15
C32-2D37-79SP11	●	37	79	169					
C32-2D38-81SP11	●	38	91	171					
C40-2D39-83SP11	●	39	83	183					
C40-2D40-85SP11	●	40	85	185					
C40-2D41-87SP11	●	41	87	187					
C40-2D42-89SP14	●	42	89	189					
C40-2D43-91SP14	●	43	91	191					
C40-2D44-93SP14	●	44	93	193					
C40-2D45-95SP14	●	45	95	195					
C40-2D46-97SP14	●	46	97	197	40	70	SPMG140512	M5	T20
C40-2D47-99SP14	●	47	99	199					
C40-2D48-101SP14	●	48	101	201					
C40-2D49-103SP14	●	49	103	203					
C40-2D50-105SP14	●	50	105	205					

● Stock ○ Available upon Order

SPMG3D Fast Drilling(U Drill)

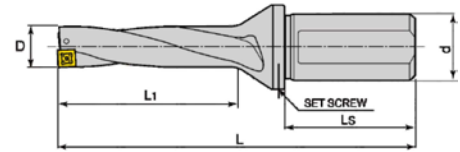

Ordering Code	Stock	D (mm)	L1 (mm)	L (mm)	d (mm)	LS (mm)	Insert	Screw	Wrench
C20-3D13-42SP05	●	13	42	101	20	50	SPMG050204	M2	T6
C20-3D13.5-44SP05	●	13.5	44	103					
C20-3D14-45SP05	●	14	45	104					
C20-3D14.5-47SP05	●	14.5	47	106					
C20-3D15-48SP05	●	15	48	107					
C20-3D15.5-50SP06	●	15.5	50	109					
C20-3D16-51SP06	●	16	51	110					
C20-3D16.5-53SP06	●	16.5	53	112					
C25-3D17-54SP06	●	17	54	125					
C25-3D17.5-56SP06	●	17.5	56	127					
C25-3D18-57SP06	●	18	57	128					
C25-3D18.5-59SP06	●	18.5	59	130					
C25-3D19-60SP06	●	19	60	131					
C25-3D19.5-62SP06	●	19.5	62	133					
C25-3D20-63SP06	●	20	63	134					
C25-3D20.5-65SP06	●	20.5	65	136					
C25-3D21-66SP06	●	21	66	137					
C25-3D21.5-68SP06	●	21.5	68	139					
C25-3D22-69SP07	●	22	69	140					
C25-3D22.5-71SP07	●	22.5	71	142					
C25-3D23-72SP07	●	23	72	146					
C25-3D23.5-74SP07	●	23.5	74	148					
C25-3D24-75SP07	●	24	75	149					
C25-3D24.5-77SP07	●	24.5	77	151					
C25-3D25-78SP07	●	25	78	152					
C32-3D25.5-80SP07	●	25.5	80	160					
C32-3D26-81SP07	●	26	81	161					
C32-3D26.5-83SP07	●	26.5	83	163					
C32-3D27-84SP07	●	27	84	164					
C32-3D27.5-86SP07	●	27.5	86	166					
C32-3D28-87SP09	●	28	87	167					
C32-3D28.5-89SP09	●	28.5	89	169					
C32-3D29-91SP09	●	29	91	172					
C32-3D29.5-93SP09	●	29.5	93	174					
C32-3D30-94SP09	●	30	94	178					
C32-3D31-97SP09	●	31	97	181					
C32-3D32-100SP09	●	32	100	184					
C32-3D33-103SP09	●	33	103	187					
C32-3D34-106SP11	●	34	106	190					
C32-3D35-109SP11	●	35	109	193					
C32-3D36-112SP11	●	36	112	196					
C32-3D37-116SP11	●	37	116	206					
C32-3D38-119SP11	●	38	119	207					
C40-3D39-122SP11	●	39	122	222					
C40-3D40-125SP11	●	40	125	225					
C40-3D41-128SP11	●	41	128	228					
C40-3D42-131SP14	●	42	131	231					
C40-3D43-134SP14	●	43	134	234					
C40-3D44-137SP14	●	44	137	237					
C40-3D45-140SP14	●	45	140	240					
C40-3D46-143SP14	●	46	143	243					
C40-3D47-146SP14	●	47	146	246					
C40-3D48-149SP14	●	48	149	249					
C40-3D49-152SP14	●	49	152	252					
C40-3D50-155SP14	●	50	155	255					

● Stock ○ Available upon Order

Turning inserts

External turning

Internal turning

Grooving & parting

Threading

Milling

Boring & drilling

Tool holder

Solid carbide end mills

Solid carbide drill & taps

Technical information

SPMG4D Fast Drilling(U Drill)

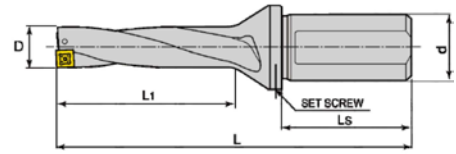

Ordering Code	Stock	D (mm)	L1 (mm)	L (mm)	d (mm)	LS (mm)	Insert	Screw	Wrench
C20-4D13-55SP05	●	13	55	114	20	50	SPMG050204	M2	T6
C20-4D13.5-57SP05	●	13.5	57	116					
C20-4D14-59SP05	●	14	59	118					
C20-4D14.5-61SP05	●	14.5	61	120					
C20-4D15-63SP05	●	15	63	122					
C20-4D15.5-65SP06	●	15.5	65	124					
C20-4D16-67SP06	●	16	67	126					
C20-4D16.5-69SP06	●	16.5	69	128	25	56	SPMG060204	M2.2	T6
C25-4D17-71SP06	●	17	71	142					
C25-4D17.5-73SP06	●	17.5	73	144					
C25-4D18-75SP06	●	18	75	146					
C25-4D18.5-77SP06	●	18.5	77	148					
C25-4D19-79SP06	●	19	79	150					
C25-4D19.5-81SP06	●	19.5	81	152					
C25-4D20-83SP06	●	20	83	154					
C25-4D20.5-85SP06	●	20.5	85	156					
C25-4D21-87SP06	●	21	87	158					
C25-4D21.5-89SP06	●	21.5	89	160					
C25-3D22-91SP07	●	22	91	162					
C25-4D22.5-93SP07	●	22.5	93	164					
C25-4D23-95SP07	●	23	95	169					
C25-4D23.5-97SP07	●	23.5	97	171	32	60	SPMG07T38	M2.5	T8
C25-4D24-99SP07	●	24	99	173					
C25-4D24.5-101SP07	●	24.5	101	175					
C25-4D25-103SP07	●	25	103	177					
C32-4D25.5-105SP07	●	25.5	105	185					
C32-4D26-107SP07	●	26	107	187					
C32-4D26.5-109SP07	●	26.5	109	189					
C32-4D27-111SP07	●	27	111	191					
C32-4D27.5-113SP07	●	27.5	113	193					
C32-4D28-115SP09	●	28	115	195					
C32-4D28.5-117SP09	●	28.5	117	197					
C32-4D29-120SP09	●	29	120	201	40	70	SPMG090408	M3.5	T15
C32-4D29.5-122SP09	●	29.5	122	203					
C32-4D30-124SP09	●	30	124	208					
C32-4D31-128SP09	●	31	128	212					
C32-4D32-132SP09	●	32	132	216					
C32-4D33-136SP09	●	33	136	220					
C32-4D34-140SP11	●	34	140	224					
C32-4D35-144SP11	●	35	144	228					
C32-4D36-148SP11	●	36	148	232					
C32-4D37-153SP11	●	37	153	243					
C32-4D38-157SP11	●	38	157	247					
C40-4D39-161SP11	●	39	161	261					
C40-4D40-165SP11	●	40	165	265					
C40-4D41-169SP11	●	41	169	269					
C40-4D42-173SP14	●	42	173	273					
C40-4D43-177SP14	●	43	177	277					
C40-4D44-181SP14	●	44	181	281					
C40-4D45-185SP14	●	45	185	285					
C40-4D46-189SP14	●	46	189	289					
C40-4D47-193SP14	●	47	193	293					
C40-4D48-197SP14	●	48	197	297					
C40-4D49-201SP14	●	49	201	301					
C40-4D50-205SP14	●	50	205	305					

● Stock ○ Available upon Order

WCMX2D Fast Drilling(U Drill)

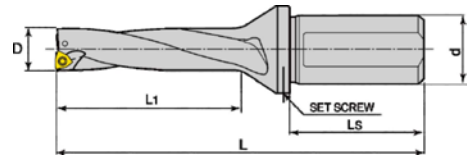

Ordering Code	Stock	D (mm)	L1 (mm)	L (mm)	DS (mm)	LS (mm)	Insert	Screw	Wrench
C25-2D15-33WC03	●	15	33	104	25	56	WCMX030208	M2.5	T8
C25-2D15.5-34WC03	●	15.5	34	105					
C25-2D16-35WC03	●	16	35	106					
C25-2D16.5-36WC03	●	16.5	36	107					
C25-2D17-37WC03	●	17	37	108					
C25-2D17.5-38WC03	●	17.5	38	109					
C25-2D18-39WC03	●	18	39	110					
C25-2D18.5-40WC03	●	18.5	40	111					
C25-2D19-41WC03	●	19	41	112					
C25-2D19.5-42WC03	●	19.5	42	113					
C25-2D20-43WC03	●	20	43	114					
C25-2D20.5-44WC03	●	20.5	44	115					
C25-2D21-45WC04	●	21	45	116					
C25-2D21.5-46WC04	●	21.5	46	117					
C25-2D22-47WC04	●	22	47	118					
C25-2D22.5-48WC04	●	22.5	48	119					
C25-2D23-49WC04	●	23	49	123					
C25-2D23.5-50WC04	●	23.5	50	124					
C25-2D24-51WC04	●	24	51	125					
C25-2D24.5-52WC04	●	24.5	52	126					
C25-2D25-53WC05	●	25	53	127					
C32-2D25.5-54WC05	●	25.5	54	134	32	60	WCMX050308	M3	T8
C32-2D26-55WC05	●	26	55	135					
C32-2D26.5-56WC05	●	26.5	56	136					
C32-2D27-57WC05	●	27	57	137					
C32-2D28-59WC05	●	28	59	139					
C32-2D29-62WC05	●	29	61	143					
C32-2D30-64WC05	●	30	64	148					
C32-2D31-66WC06	●	31	66	150					
C32-2D32-68WC06	●	32	68	152					
C32-2D33-70WC06	●	33	70	154					
C32-2D34-72WC06	●	34	72	156					
C32-2D35-74WC06	●	35	74	158					
C32-2D36-76WC06	●	36	76	160					
C32-2D37-79WC06	●	37	79	169					
C32-2D38-81WC06	●	38	81	171					
C40-2D39-83WC06	●	39	83	183	40	70	WCMX06T308	M3.5	T15
C40-2D40-85WC06	●	40	85	185					
C40-2D41-87WC06	●	41	87	187					
C40-2D42-89WC06	●	42	89	189					
C40-2D43-91WC06	●	43	91	191					
C40-2D44-93WC06	●	44	93	193					
C40-2D45-95WC06	●	45	95	195					
C40-2D46-97WC06	●	46	97	197					
C40-2D47-99WC06	●	47	99	199					
C40-2D48-101WC08	●	48	101	201					
C40-2D49-103WC06	●	49	103	203					
C40-2D50-105WC08	●	50	105	205					
C40-2D51-107WC08	●	51	107	207					
C40-2D52-109WC08	●	52	109	209					
C40-2D53-111WC08	●	53	111	211					
C40-2D54-113WC08	●	54	113	213					
C40-2D55-115WC08	●	55	115	215					
C40-2D56-120WC08	●	56	120	222					
C40-2D57-122WC08	●	57	122	224					
C40-2D58-124WC08	●	58	124	226					
C40-2D59-126WC08	●	59	126	228					
C40-2D60-128WC08	●	60	128	230					
C40-2D54-113WC08	●	54	113	213	40	70	WCMX080412	M4	T15
C40-2D55-115WC08	●	55	115	215					
C40-2D56-120WC08	●	56	120	222					
C40-2D57-122WC08	●	57	122	224					
C40-2D58-124WC08	●	58	124	226					
C40-2D59-126WC08	●	59	126	228					
C40-2D60-128WC08	●	60	128	230					

● Stock ○ Available upon Order

Turning inserts

External turning

Internal turning

Grooving & parting

Threading

Milling

Boring & drilling

Tool holder

Solid carbide end mills

Solid carbide drill & taps

Technical information

WCMX3D Fast Drilling(U Drill)

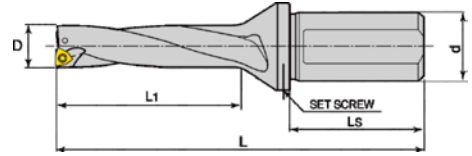

Ordering Code	Stock	D (mm)	L1 (mm)	L (mm)	DS (mm)	LS (mm)	Insert	Screw	Wrench
C25-3D15-48WC03	●	15	48	119	25	56	WCMX030208	M2.5	T8
C25-3D15.5-50WC03	●	15.5	50	121					
C25-3D16-51WC03	●	16	51	122					
C25-3D16.5-53WC03	●	16.5	53	124					
C25-3D17-54WC03	●	17	54	125					
C25-3D17.5-56WC03	●	17.5	56	127					
C25-3D18-57WC03	●	18	57	128					
C25-3D18.5-59WC03	●	18.5	59	130					
C25-3D19-60WC03	●	19	60	131					
C25-3D19.5-62WC03	●	19.5	62	133					
C25-3D20-63WC03	●	20	63	134					
C25-3D20.5-65WC03	●	20.5	65	136					
C25-3D21-66WC04	●	21	66	137					
C25-3D21.5-68WC04	●	21.5	68	139					
C25-3D22-69WC04	●	22	69	140					
C25-3D22.5-71WC04	●	22.5	71	142					
C25-3D23-72WC04	●	23	72	146					
C25-3D23.5-74WC04	●	23.5	74	148					
C25-3D24-75WC04	●	24	75	149					
C25-3D24.5-77WC04	●	24.5	77	151					
C25-3D25-78WC05	●	25	78	152					
C32-3D25.5-80WC05	●	25.5	80	160	32	60	WCMX050308	M3	T8
C32-3D26-81WC05	●	26	81	161					
C32-3D26.5-83WC05	●	26.5	83	163					
C32-3D27-84WC05	●	27	84	164					
C32-3D28-87WC05	●	28	87	167					
C32-3D29-91WC05	●	29	91	172					
C32-3D30-94WC05	●	30	94	178					
C32-3D31-97WC06	●	31	97	181					
C32-3D32-100WC06	●	32	100	184					
C32-3D33-103WC06	●	33	103	187					
C32-3D34-106WC06	●	34	106	190					
C32-3D35-109WC06	●	35	109	193					
C32-3D36-112WC06	●	36	112	196					
C32-3D37-116WC06	●	37	116	206					
C32-3D38-119WC06	●	38	119	209					
C40-3D39-122WC06	●	39	122	222	40	70	WCMX06T308	M3.5	T15
C40-3D40-125WC06	●	40	125	225					
C40-3D41-128WC06	●	41	128	228					
C40-3D42-131WC06	●	42	131	231					
C40-3D43-134WC06	●	43	134	234					
C40-3D44-137WC06	●	44	137	237					
C40-3D45-140WC06	●	45	140	240					
C40-3D46-143WC06	●	46	143	243					
C40-3D47-146WC06	●	47	146	246					
C40-3D48-149WC08	●	48	149	249					
C40-3D49-152WC06	●	49	152	252					
C40-3D50-155WC08	●	50	155	255					
C40-3D51-158WC08	●	51	158	258					
C40-3D52-161WC08	●	52	161	261					
C40-3D53-164WC08	●	53	164	264					
C40-3D54-167WC08	●	54	167	267					
C40-3D55-170WC08	●	55	170	270					
C40-3D56-176WC08	●	56	176	278					
C40-3D57-179WC08	●	57	179	281					
C40-3D58-182WC08	●	58	182	284					
C40-3D59-185WC08	●	59	185	287					
C40-3D60-188WC08	●	60	188	290					
C40-3D60-188WC08	●	60	188	290					

● Stock ○ Available upon Order

WCMX4D Fast Drilling(U Drill)

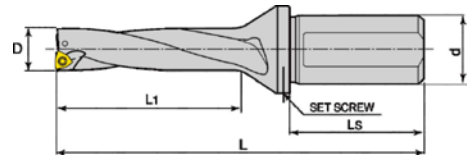

Ordering Code	Stock	D (mm)	L1 (mm)	L (mm)	DS (mm)	LS (mm)	Insert	Screw	Wrench
C25-4D15-63WC03	●	15	63	134	25	56	WCMX030208	M2.5	T8
C25-4D15.5-65WC03	●	15.5	65	136					
C25-4D16-67WC03	●	16	67	138					
C25-4D16.5-69WC03	●	16.5	69	140					
C25-4D17-71WC03	●	17	71	142					
C25-4D17.5-73WC03	●	17.5	73	144					
C25-4D18-75WC03	●	18	75	146					
C25-4D18.5-77WC03	●	18.5	77	148					
C25-4D19-79WC03	●	19	79	150					
C25-4D19.5-81WC03	●	19.5	81	152					
C25-4D20-83WC03	●	20	83	156					
C25-4D20.5-85WC03	●	20.5	85	158					
C25-4D21-87WC04	●	21	87	160					
C25-4D21.5-89WC04	●	21.5	89	162					
C25-4D22-91WC04	●	22	91	164					
C25-4D22.5-93WC04	●	22.5	93	179					
C25-4D23-95WC04	●	23	95	171					
C25-4D23.5-97WC04	●	23.5	97	173					
C25-4D24-99WC04	●	24	99	175					
C25-4D24.5-101WC04	●	24.5	101	177					
C25-4D25-103WC05	●	25	103	185					
C32-4D25.5-105WC05	●	25.5	105	187					
C32-4D26-107WC05	●	26	107	189					
C32-4D26.5-109WC05	●	26.5	109	191					
C32-4D27-111WC05	●	27	111	193					
C32-4D28-115WC05	●	28	115	195					
C32-4D29-120WC05	●	29	120	201					
C32-4D30-124WC05	●	30	124	208					
C32-4D31-128WC06	●	31	128	212					
C32-4D32-132WC06	●	32	132	216					
C32-4D33-136WC06	●	33	136	220					
C32-4D34-140WC06	●	34	140	224					
C32-4D35-144WC06	●	35	144	228					
C32-4D36-148WC06	●	36	148	232					
C32-4D37-153WC06	●	37	153	243					
C32-4D38-157WC06	●	38	157	247					
C40-4D39-161WC06	●	39	161	261					
C40-4D40-165WC06	●	40	165	265					
C40-4D41-169WC06	●	41	169	269					
C40-4D42-173WC06	●	42	173	273					
C40-4D43-177WC06	●	43	177	277					
C40-4D44-181WC06	●	44	181	281					
C40-4D45-185WC06	●	45	185	285					
C40-4D46-189WC06	●	46	189	289					
C40-4D47-193WC06	●	47	193	293					
C40-4D48-197WC08	●	48	197	297					
C40-4D49-201WC06	●	49	201	301					
C40-4D50-205WC08	●	50	205	305					
C40-4D51-209WC08	●	51	209	309					
C40-4D52-213WC08	●	52	213	313					
C40-4D53-217WC08	●	53	217	317					
C40-4D54-221WC08	●	54	221	321					
C40-4D55-225WC08	●	55	225	325					
C40-4D56-232WC08	●	56	232	334					
C40-4D57-236WC08	●	57	236	338					
C40-4D58-240WC08	●	58	240	342					
C40-4D59-244WC08	●	59	244	346					
C40-4D60-248WC08	●	60	248	350					

● Stock ○ Available upon Order

- Turning inserts
- External turning
- Internal turning
- Grooving & parting
- Threading
- Milling
- Boring & drilling
- Tool holder
- Solid carbide end mills
- Solid carbide drill & taps
- Technical information

Turning inserts

External turning

Internal turning

Grooving & parting

Threading

Milling

Boring & drilling

Tool holder

Solid carbide end mills

Solid carbide drill & taps

Technical information

SPMG-DG Drilling Inserts



M P

The material
 ● P1115
 ○ P1225

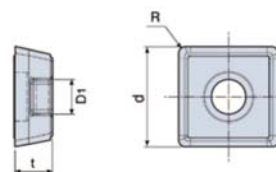

Ordering Code	TS4125	d(mm)	t(mm)	R(mm)	D1(mm)
SPMG 050204 NM	●	5.00	2.38	0.4	2.25
SPMG 060204 NM	●	6.00	2.38	0.4	2.61
SPMG 07T308 NM	●	7.94	3.97	0.8	2.85
SPMG 090408 NM	●	9.80	4.30	0.8	4.05
SPMG 110408 NM	●	11.50	4.80	0.8	4.45
SPMG 120408 NM	●	12.70	4.76	0.8	4.37
SPMG 140512 NM	●	14.30	5.20	1.2	5.75

SPGG-DA Drilling Inserts



N

The material
 ● N9115
 ○ N9225

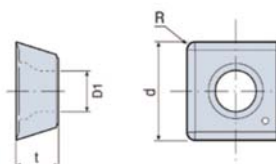

Ordering Code	TN9125	d(mm)	t(mm)	R(mm)	D1(mm)
SPMG 050204 NL	○	5.00	2.38	0.4	2.25
SPMG 060204 NL	○	6.00	2.38	0.4	2.61
SPMG 07T308 NL	○	7.94	3.97	0.8	2.85
SPMG 090408 NL	○	9.80	4.30	0.8	4.05
SPMG 110408 NL	○	11.50	4.80	0.8	4.45
SPMG 140512 NL	○	14.30	5.20	1.2	5.75

WCMX-WCGX-S Drilling Inserts



M P

The material
 ● P1115
 ○ P1225

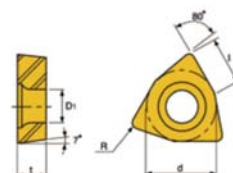

Ordering Code	TP 1115	d(mm)	t(mm)	R(mm)	D1(mm)	l(mm)
WCMX 030204-NM	●	5.56	2.38	0.4	2.55	3.8
WCMX 040204-NM	●	6.35	2.38	0.4	2.8	4.3
WCMX 050308-NM	●	7.94	3.18	0.8	3.4	5.4
WCMX 06T308-NM	●	9.52	3.97	0.8	4.4	6.5
WCMX 080408-NM	●	12.70	4.76	0.8	5.5	8.7

● Stock ○ Available upon Order

Eccentric Sleeve

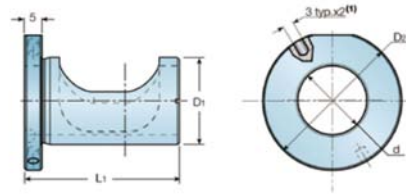

Ordering Code	Stock	d(mm)	D1(mm)	R(mm)	D2(mm)
PXTD 20x25	●	20	25	50	88
PXTD 25x32	●	25	32	50	94
PXTD 32x40	●	32	45	60	152
PXTD 40x50	●	40	50	60	157

Milling Application

When milling machine processing, such as the diameter of the need to change the normal processing adjustable axial location of eccentric sleeve.

If want to enlarge the aperture, clockwise rotating sleeve;

If want to reduce the aperture, the socket counterclockwise, specific as follows; Bit diameter: 30mm

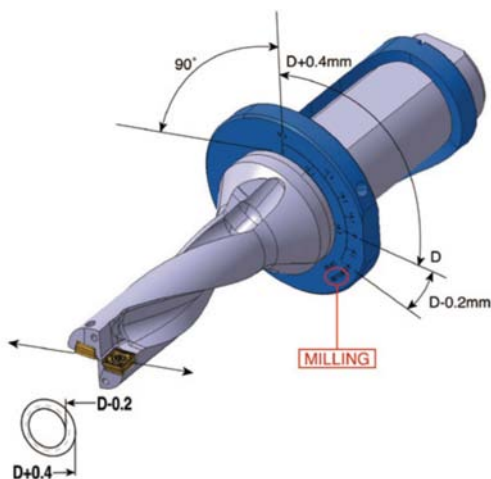

Lathe Application

Axial and eccentric sleeve can drill spindle axial overlap in the range of 0.2mm (the eccentric sleeve counterclockwise to increase the aperture adjustment)

When used in lathe processing, eccentric sleeve bit adjustable axial with spindle axial position

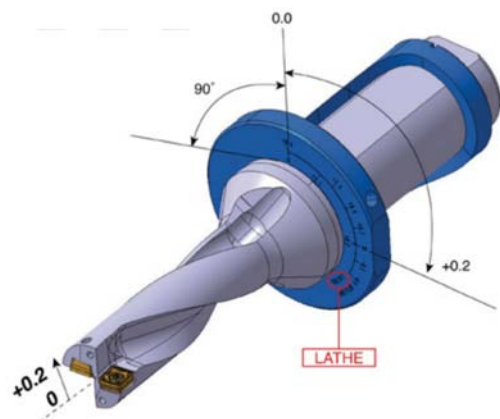

Turning inserts

External turning

Internal turning

Grooving & parting

Threading

Milling

Boring & drilling

Tool holder

Solid carbide end mills

Solid carbide drill & taps

Technical information

Lathe application technical information

Bit installation and test

First hole drilling processing—first 3mm–6mm depth when the blade, detecting core diameter range should be 0.2mm to 0.7mm

If you do not produce core diameter:

- blade and vibration drilling processing will produce crack
- please rotating drill shank of 180 degrees and then to test

If you core diameter size beyond the recommended data:

- please adjust offset the core diameter control in the recommended range
- otherwise the drilling process will cause overload and vibration

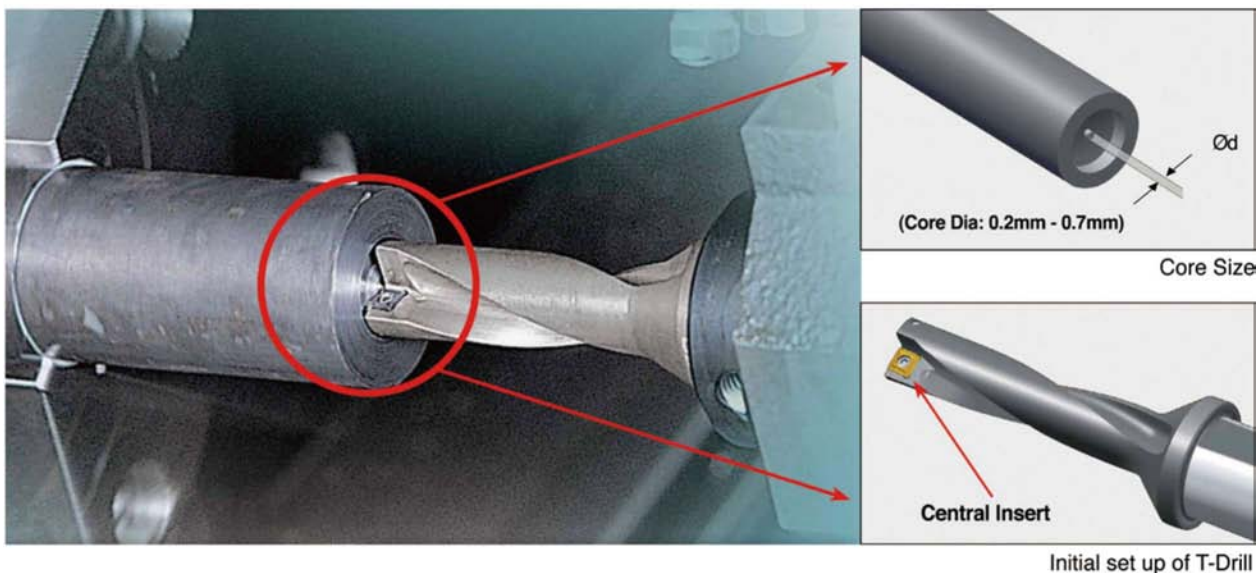

Cutting parameter for fast drill

Material	Carbon steel S50C, Q235		Alloy steel 25–35HRC 4Cr5MoSiV1, Cr12		Stainless steel SUS304, 316, 0Cr19Ni9		Cast iron HT250, QT450		Aluminium alloy	
	Vc=m/min	f=mm/rev	Vc=m/min	f=mm/rev	Vc=m/min	f=mm/rev	Vc=m/min	f=mm/rev	Vc=m/min	f=mm/rev
Speed										
Dc										
12.5–15	160–250	0.05–0.12	120–180	0.06–0.12	150–200	0.05–0.10	150–250	0.06–0.12	250–350	0.06–0.12
16–21		0.06–0.15		0.08–0.15		0.06–0.12		0.08–0.15		
22–28		0.06–0.18		0.10–0.20		0.08–0.15		0.10–0.20		
29–33		0.07–0.20		0.12–0.25		0.09–0.16		0.12–0.25		
34–41		0.08–0.25		0.12–0.25		0.10–0.18		0.15–0.25		
42–50		0.08–0.25		0.12–0.25		0.10–0.20		0.18–0.30		
51–60	0.06–0.15	0.08–0.15	0.06–0.12	0.10–0.20						

Non standard size

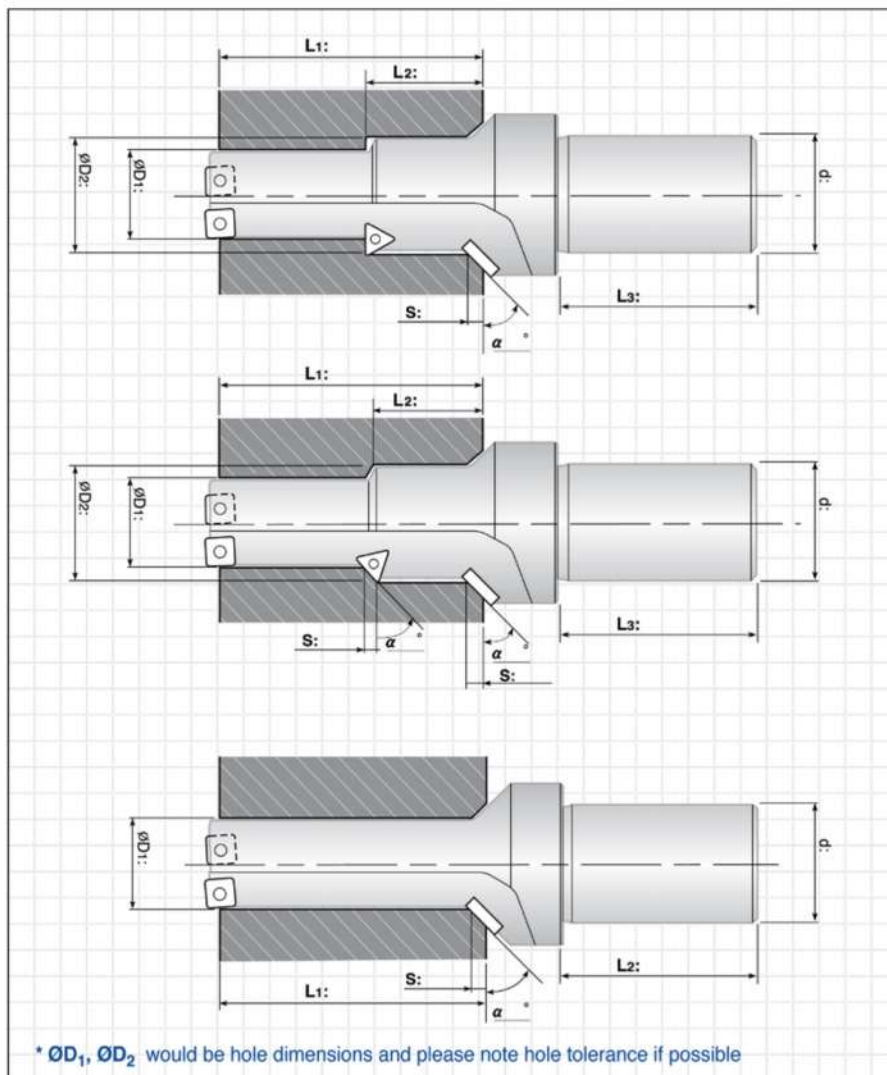

Shank type

Cylindrical shank (ISO 9766)

Weldon shank

Whistle notch shank

Coolant supply

Internal

External

Machine Type

Horizontal

Vertical

Hole Type

Blind hole

Through hole

Workpieces

Part: _____

Material: _____

Hardness: _____

Quantity

• _____ pcs

Comment

■ **Customer :** _____ ■ **Contact :** _____

■ **Address:** _____

■ **Telephone:** _____ ■ **Fax:** _____

■ **E-mail:** _____

- Turning inserts
- External turning
- Internal turning
- Grooving & parting
- Threading
- Milling
- Boring & drilling
- Tool holder
- Solid carbide end mills
- Solid carbide drill & taps
- Technical information



Tool Holder Series



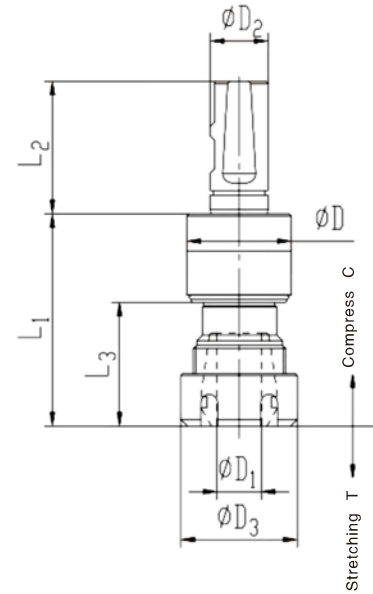

• ERNuts S type for the internal cooling type, A type for the cold type.

Unit: mm

Model	Stock	ERJacket	ϕD	$\phi D1$	$\phi D2$	$\phi D3$	L1	L2	L3	C	T	Applicable taps
VLERS20-C25	●	ER20	34	4.5-10	25	34	68	57	45	0.5	0.5	M4-M12 (Nr.8-7/16)
VLERS32-C25	●	ER32	45	4.5-16	25	50	90	57	51	0.5	0.5	

● Stock ○ Available upon Order

Characteristic

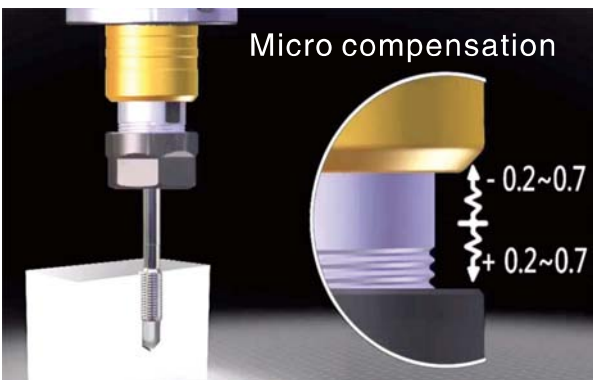
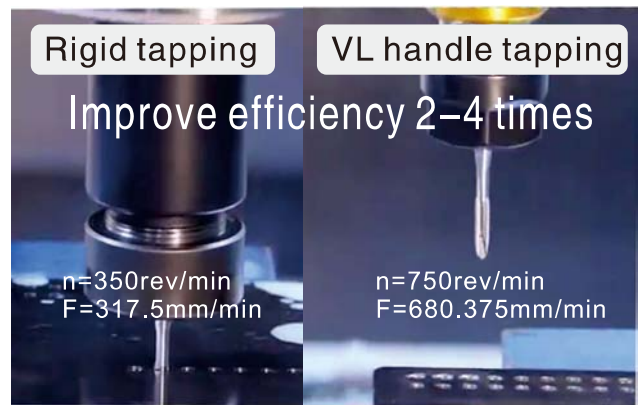
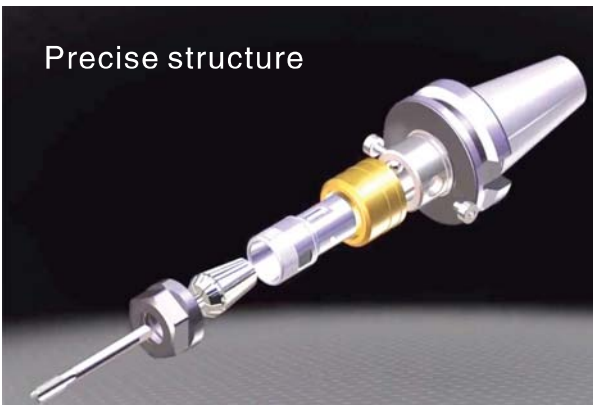

Turning inserts

External turning

Internal turning

Grooving & parting

Threading

Milling

Boring & drilling

Tool holder

Solid carbide end mills

Solid carbide drill & taps

Technical information

Turning inserts

External turning

Internal turning

Grooving & parting

Threading

Milling

Boring & drilling

Tool holder

Solid carbide end mills

Solid carbide drill & taps

Technical information

The problem we met usually as below,

- 1 The size of the hole is bigger , the accuracy of the hole dimension doesn't meet the requirements.
- 2 The middle section of the hole is oversized and two ends section are smaller. Cylindricity doesn't meet the requirements
- 3 The roughness of the hole surface finish can not meet the requirements
- 4 The reamer is not durable.
- 5 The straightness of the hole is bad.
- 6 The quality of the hole machined is not stable when mass production

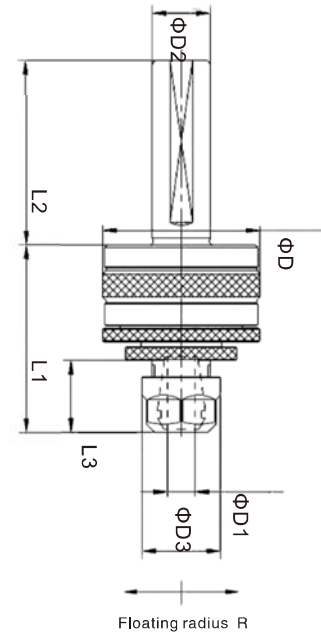

Unit: mm

Model	Stock	ERJacket	φ D1	φ D2	φ D	φ D3	L1	L2	L3	R (MAX)
SV-FTER20-D25	●	ER20	3-13	25	68	34	80	80	30	0.5

●Stock ○Available upon Order

Characteristic

Using "floating reamer holder" , it's special can make the reamer find the center line of the main spindle, by auto floating the reamer in axial and radial direction. by this way the deviation between the center line of the reamer and the center line of the hole to be reamed can be auto compensated.

A. By using this floating holder, the reamer in the reaming process can complete the reaming task flexibly, smoothly and evenly, the reamed hole roundness and cylindrical degree can reach to 0.002mm, the roughness can reach to Ra0.2 μ m.

B. The spindle and center of the reamer in the floating range that can keep coincident with the center of the workpieces all the time. All flutes of the reamer cut evenly and no shock. It can make the life of the reamer longer more than 5 times.

The possible deviation of the reaming process

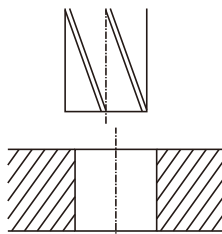

1、The center line of the pre-processing hole deviated from the center line of the reamer.

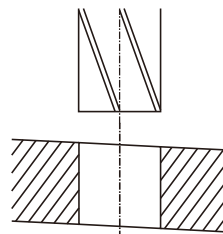

2、There is angle between pre-processing hole center and reamer

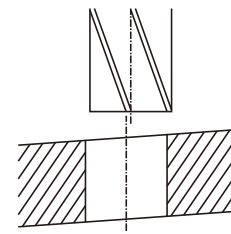

3、The deviation in picture 1 and picture 2 are existing at the same time.

Milling Chuck



P238

Apu Drill Chuck Holder



P238

Collet Chuck



P239

SK Collet Chuck



P240

SK Collet Chuck



P241

FMA Face Mill Holder



P242

FMB Mill Holder



P243

SLN Side Lock End Mill Holder



P244

NC



P245

NC



P245

Shrink Chuck



P246

BT Hydraulic Chuck



P247

MX Collet Chuck



P247

TPM



P248

TER



P248

Taper Chuck



P249

SK□-L1



P250

FMB□-L1



P251

SLN□-L1



P252

ER Collet Chuck DIN69893



P253

End Mill Holder Weldon DIN69893



P253

FMB Face Mill Holder



P254

Micro compensation tapping tool holder



P255

Floating knife series



P255

Turning inserts

External turning

Internal turning

Grooving & parting

Threading

Milling

Boring & drilling

Tool holder

Solid carbide end mills

Solid carbide drill & taps

Technical information

- Turning inserts
- External turning
- Internal turning
- Grooving & parting
- Threading
- Milling
- Boring & drilling
- Tool holder**
- Solid carbide end mills
- Solid carbide drill & taps
- Technical information

ER Collet Chuck Holder



P256

ER Collet



P257

Sealed Collet with Slitting



P257

ER Straight Collet



P258

SC Sealed Collet



P258

SKS Collet



P259

MX Collet



P259

BT Pull Studs



P260

JT Pull Studs



P260

ER Clamping Nuts



P261

Clamping Nuts



P261

Wrenches



P262

Milling Chuck

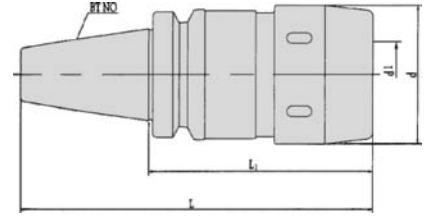

Ordering Code		Stock	d1	d	L1	Draw Bar
BT30	GMC16-80	○	16	45	80	M12
	GMC20-75	●	20	50	80	
	GMC25-90	●	25	55	80	
BT40	GMC16-90	○	16	45	90	M16
	GMC20-80	●	20	50	90	
	GMC25-90	●	25	55	90	
	GMC32-105	●	32	72.5	105	
BT50	GMC32-110	●	32	72.5	110	M24
	GMC32-165	●	32	72.5	150	
	GMC32-200	●	32	72.5	200	
	GMC32-250	●	32	72.5	250	
	GMC32-300	●	32	72.5	300	
	GMC42-110	●	42	82	110	
	GMC42-150	●	42	82	150	
	GMC42-200	●	42	82	200	
	GMC42-250	●	42	82	250	
	GMC42-300	●	42	82	300	

Apu Drill Chuck Holder

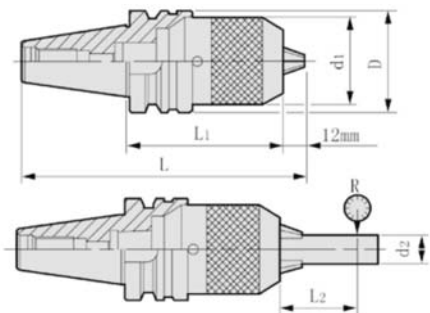

Ordering Code	Stock	L	L1	d
BT30-APU08-80	●	128.4	80	37
BT30-APU13-110	●	148.4	100	49
BT30-APU16-110	●	163.4	115	54
BT40-APU08-85	●	150.4	85	37
BT40-APU13-105	●	170.4	105	49
BT40-APU16-110	●	185.4	120	54
BT50-APU08-90	●	196.8	95	37
BT50-APU13-120	●	221.8	120	49
BT50-APU16-130	○	231.8	130	54
BT50-APU16-165	○	266.8	165	54
BT50-APU16-190	●	291.8	190	54

● Stock ○ Available upon Order

Turning inserts

External turning

Internal turning

Grooving & parting

Threading

Milling

Boring & drilling

Tool holder

Solid carbide end mills

Solid carbide drill & taps

Technical information

Collet Chuck

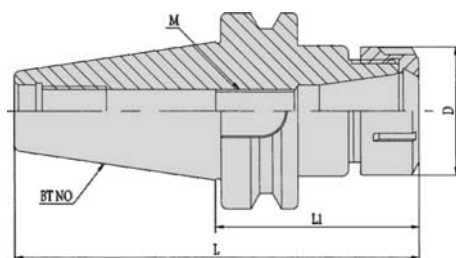

Ordering Code	Stock	Capacity	L	L1	D	Collet	NUT	Wrench
BT30-ER11-60	●	0.5-7	108.4	60	19	ER11	CAN-ER11	W-ER11A
-100			148.4	100	19			
BT30-ER16-60	●	1-10	108.4	60	28	ER16	CAN-ER16	W-ER16A
-100			148.4	100	28			
BT30-ER20-60	●	2-13	108.4	60	34	ER20	CAN-ER20	W-ER20A
-100			148.4	100	34			
BT30-ER25-60	●	2-16	108.4	60	42	ER25	CAUM-ER25	W-ER25UM
-100			148.4	100	42			
BT30-ER32-60	●	3-20	108.4	60	50	ER32	CAUM-ER32	W-ER32UM
-100			148.4	100	50			
BT40-ER11-70	●	0.5-7	135.4	70	19	ER11	CAN-ER11	W-ER11A
-100			165.4	100	19			
BT40-ER16-70	●	1-10	135.4	70	28	ER16	CAN-ER16	W-ER16A
-100			165.4	100	28			
-150			215.4	150	28			
BT40-ER20-70	●	2-13	135.4	70	34	ER20	CAN-ER20	W-ER20A
-100			165.4	100	34			
-150			215.4	150	34			
BT40-ER25-70	●	2-16	135.4	70	42	ER25	CAUM-ER25	W-ER25UM
-100			165.4	100	42			
-150			215.4	150	42			
BT40-ER32-70	●	3-20	135.4	70	50	ER32	CAUM-ER32	W-ER32UM
-100			165.4	100	50			
-150			215.4	150	50			
BT40-ER40-80	●	3-26	135.4	70	63	ER40	CAUM-ER40	W-ER40UM
-100			165.4	100	63			
-150			215.4	150	63			
BT50-ER16-70	●	1-10	171.8	70	28	ER16	CAN-ER16	W-ER16A
-100			201.8	100	28			
-150			251.8	150	28			
BT50-ER20-70	●	2-13	171.8	70	34	ER20	CAN-ER20	W-ER20A
-100			201.8	100	34			
-150			251.8	150	34			
BT50-ER25-70	●	2-16	171.8	70	42	ER25	CAUM-ER25	W-ER25UM
-100			201.8	100	42			
-150			251.8	150	42			
BT50-ER32-70	●	3-20	171.8	70	50	ER32	CAUM-ER32	W-ER32UM
-100			201.8	100	50			
-150			251.8	150	50			
BT50-ER40-80	●	3-26	181.8	80	63	ER40	CAUM-ER40	W-ER40UM
-100			201.8	100	63			
-150			251.8	150	63			
-200			301.8	200	63			

● Stock ○ Available upon Order

SK Collet Chuck BT □-SK□-L1

- BT taper shank is in conformity with AT3 standard
- Concentricity of the inner and outer cone 0.005mm
- Default balancing design

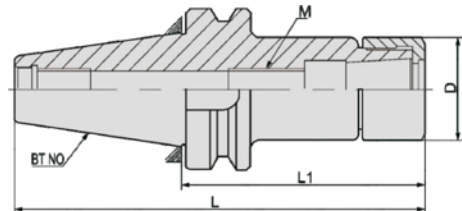

Ordering Code	Stock	Capacity	L	L1	D	Collet	Nut	Wrench
BT30-SK06-60	●	2-6	108.4	60	20	SK06	SK06	OW/SK06 or OB/SK06
-80	●		128.4	80				
BT30-SK10-70	●	2-10	118.4	70	27	SK10	SK10	OW/SK10 or OB/SK10
-95	●		143.4	95				
BT30-SK16-60	●	3-16	108.4	60	40	SK16	SK16	A/38-42 or OB/SK16
-80	●		128.4	80				
-100	●		148.4	100				
BT30-SK25-80	●	6-25.4	128.4	80	54	SK25	SK25	A/45-52 or OB/SK25
BT40-SK06-65	●	2-6	130.4	65	20	SK06	SK06	OW/SK06 or OB/SK06
-85	●		150.4	85				
BT40-SK10-55	●	2-10	120.4	55	27	SK10	SK10	OW/SK10 or OB/SK10
-80	●		145.4	80				
-100	●		165.4	100				
-150	●		215.4	150				
BT40-SK16-55	●	3-16	120.4	55	40	SK16	SK16	A/38-42 or OB/SK16
-80	●		145.4	80				
-100	●		165.4	100				
-150	●		215.4	150				
BT40-SK25-70	●	6-25.4	135.4	70	54	SK25	SK25	A/45-52 or OB/SK25
-95	●		160.4	95				
-110	●		175.4	110				
BT50-SK06-70	●	2-6	171.8	70	20	SK06	SK06	OW/SK06 or OB/SK06
-100	●		201.8	100				
BT50-SK10-100	●	2-10	201.8	100	27	SK10	SK10	OW/SK10 or OB/SK10
-130	●		231.8	130				
-150	●		251.8	150				
BT50-SK16-100	●	3-16	201.8	100	40	SK16	SK16	A/38-42 or OB/SK16
-130	●		231.8	130				
-150	●		251.8	150				
BT50-SK25-100	●	6-25.4	201.8	100	54	Sk25	Sk25	A/45-52 or OB/SK25
-130	●		231.8	130				
-150	●		251.8	150				

● Stock ○ Available upon Order

Turning inserts

External turning

Internal turning

Grooving & parting

Threading

Milling

Boring & drilling

Tool holder

Solid carbide end mills

Solid carbide drill & taps

Technical information

SK Collet Chuck BT □-GSK□-L1

- BT taper shank is in conformity with AT3 standard
- Concentricity of the inner and outer cone 0.005mm
- Default balancing design

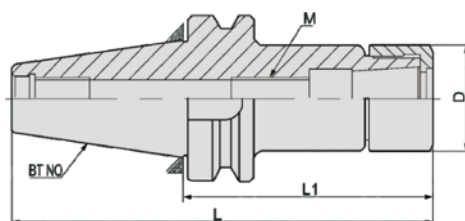

Ordering Code	Stock	Capacity	L	L1	D	Collet	Nut	Wrench
BT30-GSK06-60	●	2-6	108.4	60	20	SK06	GSK06	OB/SK06
-80	●		128.4	80				
BT30-GSK10-70	●	2-10	118.4	70	27	SK10	GSK10	OB/SK10
-95	●		143.4	95				
BT30-GSK16-60	●	3-16	108.4	60	40	SK16	GSK16	OB/SK16
-80	●		128.4	80				
-100	●		148.4	100				
-SK25-80	●	6-25.4	128.4	80	54	SK25	GSK25	OB/SK25
BT40-GSK06-65	●	2-6	130.4	65	20	SK06	GSK06	OB/SK06
-85	●		150.4	85				
BT40-GSK10-55	●	2-10	120.4	55	27	SK10	GSK10	OB/SK10
-80	●		145.4	80				
-100	●		165.4	100				
-150	●		215.4	150				
BT40-GSK16-55	●	3-16	120.4	55	40	SK16	GSK16	OB/SK16
-80	●		145.4	80				
-100	●		165.4	100				
-150	●		215.4	150				
BT40-GSK25-70	●	6-25.4	135.4	70	54	SK25	GSK25	OB/SK25
-95	●		160.4	95				
-110	●		175.4	110				
BT50-GSK06-70	●	2-6	171.8	70	20	SK06	GSK06	OB/SK06
-100	●		201.8	100				
BT50-GSK10-100	●	2-10	201.8	100	27	SK10	GSK10	OB/SK10
-130	●		231.8	130				
-150	●		251.8	150				
BT50-GSK16-100	●	3-16	201.8	100	40	SK16	GSK16	OB/SK16
-130	●		231.8	130				
-150	●		251.8	150				
BT50-GSK25-100	●	6-25.4	201.8	100	54	SK25	GSK25	OB/SK25
-130	●		231.8	130				
-150	●		251.8	150				

● Stock ○ Available upon Order

Turning inserts
 External turning
 Internal turning
 Grooving & parting
 Threading
 Milling
 Boring & drilling
 Tool holder
 Solid carbide end mills
 Solid carbide drill & taps
 Technical information

FMA Face Mill Holder

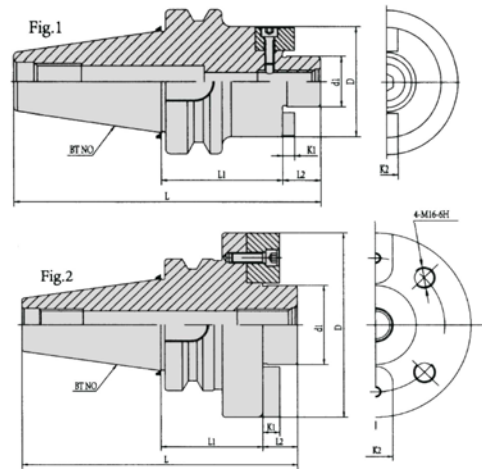

Ordering Code	Stock	Type	d1	D	L	L1	L2	K1	K2
BT30-FMA25.4-45	●	Fig.1	25.40	50	113.4	45	20	4.52	9.52
-60	128.4				60				
BT30-FMA31.75-45	●	Fig.1	31.75	60	115.4	45	22	6.70	12.70
BT40-FMA25.4-45	●	Fig.1	25.40	50	130.4	45	20	4.52	9.52
-60					145.4	60			
-90					175.4	90			
-105					190.4	105			
BT40-FMA31.75-45	●	Fig.1	31.75	60	132.4	45	22	6.70	12.70
-75					162.4	75			
-90					177.4	90			
BT40-FMA38.1-60	●	Fig.1	38.10	75	150.4	60	25	8.87	15.87
BT40-FMA50.8-60	●	Fig.1	50.80	98	161.4	60	36	9.75	19.05
BT50-FMA25.4-45	●	Fig.1	25.40	50	166.8	45	20	4.52	9.52
-90					211.8	90			
-150					271.8	150			
BT50-FMA31.75-45	●	Fig.1	31.75	60	168.8	45	22	6.70	12.70
-75					198.8	75			
-105					228.8	105			
BT50-FMA38.10-45	●	Fig.1	38.10	80	171.8	45	25	8.87	15.87
-75					201.8	75			
BT50-FMA50.80-45	●	Fig.1	50.80	98	182.8	45	36	9.75	19.05
-75					212.8	75			
BT50-FMA47.62-75	●	Fig.1	47.62	128.75	208.8	75	32	12.50	25.40

● Stock ○ Available upon Order

Turning inserts

External turning

Internal turning

Grooving & parting

Threading

Milling

Boring & drilling

Tool holder

Solid carbide end mills

Solid carbide drill & taps

Technical information

FMB Mill Holder

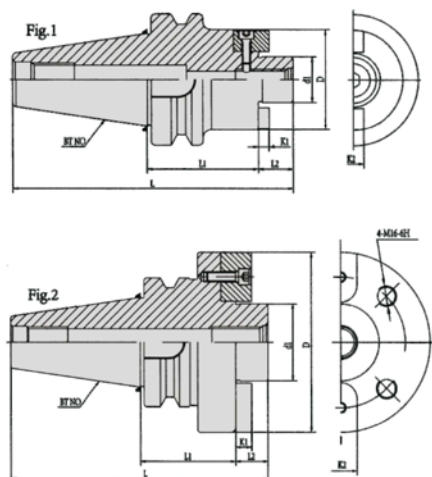

Ordering Code	Stock	Type	d1	d2	D	L	L1	L2	K1	K2	T
BT30-FMB22-45	●	Fig.1	22	26	45	109.9	45	16.5	4.8	10	M10x30
-60					124.9	60					
BT30-FMB27-45	●	Fig.1	27	33	54	111.9	45	18.5	5.8	12	M12x30
-60					126.9	60					
BT30-FMB32-60	●	Fig.1	32	41	58	130.4	60	22	6.8	14	M16x35
BT40-FMB22-45					126.9	45					
-60	●	Fig.1	22	26	48	141.9	60	16.5	4.8	10	M10x30
-100					181.9	100					
-150					231.9	150					
BT40-FMB27-45					128.9	45	18.5	5.8	12	M12x30	
-60	●	Fig.1	27	33	60	143.9					60
-100					183.9	100					
-150					233.9	150					
-200					283.9	200					
BT40-FMB32-60					147.9	60	22	6.8	14	M16x35	
-100	●	Fig.1	32	41	62	187.4					100
-150					237.4	150					
-200					287.4	200					
BT40-FMB40-60					150.4	60	25	8	16	M16x35	
-100	●	Fig.1	40	48	80	190.4					100
-150					240.4	150					
-200					290.4	200					
BT50-FMB22-60					178.3	60	16.5	4.8	10	M10x30	
-100	●	Fig.1	22	26	48	218.3					100
-150					268.3	150					
-200					318.3	200					
BT50-FMB27-60					180.3	60	18.5	5.8	12	M12x30	
-100	●	Fig.1	27	33	60	220.3					100
-150					270.3	150					
-200					320.3	200					
BT50-FMB32-60					183.8	60	22	6.8	14	M16x35	
-100	●	Fig.1	32	41	73	223.8					100
-150					273.8	150					
-200					323.8	200					
BT50-FMB40-60					186.8	60	25	8	16	M16x35	
-100	●	Fig.1	40	48	80	226.8					100
-150					276.8	150					
-200					326.8	200					
BT50-FMB60-75					201.8	75	25	12.5	25.4		
-100	●	Fig.1	60	-	140	226.8					100

● Stock ○ Available upon Order

SLN Side Lock End Mill Holder

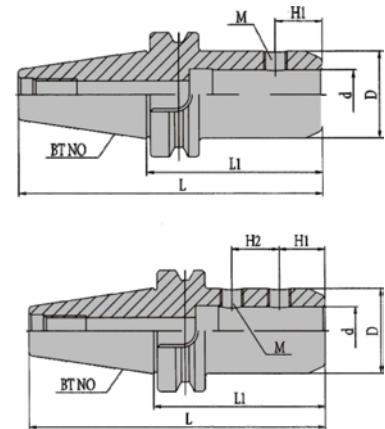

Ordering Code	Stock	Type	L	L1	H1	H2	M	D	d
BT30-SLN6-60	●	Fig.1	108.4	60	18		M6	25	6
BT30-SLN8-60	●	Fig.1					M8	28	8
BT30-SLN10-60	●	Fig.1					M10	35	10
BT30-SLN12-60	●	Fig.1					M12	42	12
BT30-SLN16-75	●	Fig.1	123.4	75	24		M14	48	16
BT30-SLN20-63	●	Fig.1	111.4	63	25		M16	52	20
BT30-SLN20-75	●	Fig.1	123.4	75		24	25	M18	65
BT30-SLN25-80	●	Fig.2	128.4	80					
BT30-SLN25-90	●	Fig.2	138.4	90					
BT30-SLN25-100	●	Fig.2	148.4	100					
BT40-SLN6-50	●	Fig.1	115.4	50	18		M6	25	6
BT40-SLN8-50	●	Fig.1					M8	28	8
BT40-SLN10-63	●	Fig.1	128.4	63	20		M10	35	10
BT40-SLN12-63	●	Fig.1			22.5		M12	42	12
BT40-SLN16-63	●	Fig.1			24		M14	48	16
BT40-SLN20-63	●	Fig.1			25		M16	52	20
BT40-SLN25-90	●	Fig.2	155.4	90	24	25	M18	65	25
BT40-SLN25-100	●	Fig.2	165.4	100					
BT40-SLN32-100	●	Fig.2	170.4	105	30	28	M20	72	32
BT40-SLN40-105	●	Fig.2				32		80	40
BT40-SLN42-105	●	Fig.2				82		42	
BT50-SLN6-63	●	Fig.1	164.8	63	18		M6	25	6
BT50-SLN8-63	●	Fig.1					M8	28	8
BT50-SLN10-63	●	Fig.1	181.8	80	20		M10	35	10
BT50-SLN12-80	●	Fig.1			22.5		M12	42	12
BT50-SLN16-80	●	Fig.1			24		M14	48	16
BT50-SLN20-80	●	Fig.1			25		M16	52	20
BT50-SLN25-100	●	Fig.2	201.8	100	24	25	M18	65	25
BT50-SLN32-105	●	Fig.2	206.8	105					
BT50-SLN40-115	●	Fig.2	216.8	115	30	32	M20	80	40
BT50-SLN42-100	●	Fig.2						221.8	120

● Stock ○ Available upon Order

Turning inserts

External turning

Internal turning

Grooving & parting

Threading

Milling

Boring & drilling

Tool holder

Solid carbide end mills

Solid carbide drill & taps

Technical information

NC Morse Taper Holder(A Type)

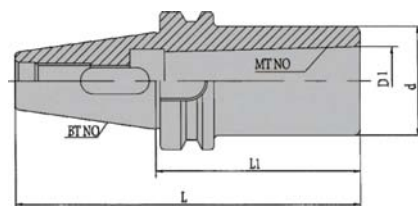

Ordering Code	Stock	L	L1	D1	D
BT40-MTA1-45	●	110.4	45	12.065	25
-120	●	185.4	120		
BT40-MTA2-16	●	125.4	60	17.78	32
-120	●	185.4	120		
BT40-MTA3-75	●	140.4	75	23.825	40
-135	●	200.4	135		
BT40-MTA4-95	●	160.4	95	31.267	48
-165	●	230.4	165		
BT50-MTA1-45	●	146.8	45	12.065	25
-120	●	221.8	120		
BT50-MTA2-60	●	161.8	60	17.78	32
-135	●	236.8	135		
BT50-MTA3-75	●	176.8	75	23.825	40
-150	●	251.8	150		
BT50-MTA4-90	●	191.8	90	31.267	48
-180	●	281.8	180		
BT50-MTA5-105	●	211.8	110	44.399	63
-210	●	311.8	210		

NC Morse Taper Holder(B Type)

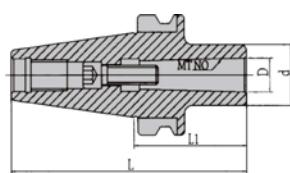

Fig 1

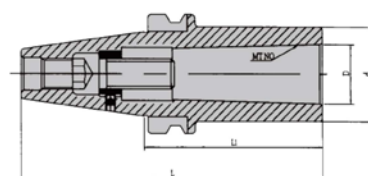

Fig 2

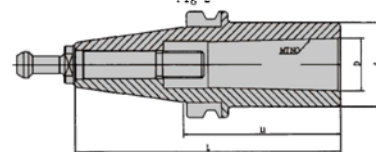
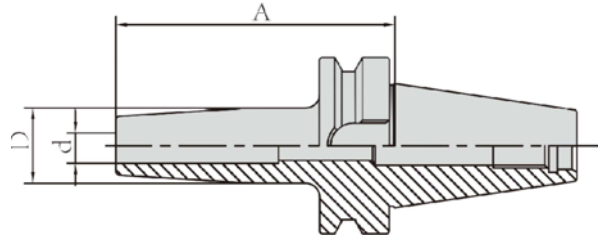

Fig 3

Ordering Code	Stock	Type	L	L1	D	d
BT40-MTB1-45	●	Fig.1	110.4	45	12.065	25
BT40-MTB2-50	●	Fig.1	115.4	50	17.78	32
BT40-MTB3-75	●	Fig.1,3	140.4	75	23.825	40
BT40-MTB4-90	●	Fig.3	155.4	90	31.267	48
BT40-MTB4-95	●	Fig.2	160.4	95	31.267	48
BT50-MTB1-45	●	Fig.1	146.8	45	12.065	25
BT50-MTB2-45	●	Fig.1	146.8	45	17.78	32
BT50-MTB3-60	●	Fig.1	161.8	60	23.825	40
BT50-MTB4-90	●	Fig.1	191.8	90	31.267	48
BT50-MTB5-120	●	Fig.2	221.8	120	44.399	63

● Stock ○ Available upon Order

Shrink Chuck



Ordering Code	Stock	d	A	D	D1	I1	I2
BT30-SRC6-90	○	6	90	24	32	41	10
BT30-SRC8-90	○	8	90	24	32	47	10
BT30-SRC10-90	○	10	90	27	34	47	10
BT30-SRC12-90	○	12	90	27	34	50	10
BT30-SRC14-90	○	14	90	33	42	50	10
BT30-SRC16-90	○	16	90	33	42	52	10
BT40-SRC6-90	●	6	90	21	27	36	10
BT40-SRC8-90	●	8	90	21	27	36	10
BT40-SRC10-90	●	10	90	24	32	41	10
BT40-SRC12-90	●	12	90	24	32	47	10
BT40-SRC14-90	●	14	90	27	34	47	10
BT40-SRC16-90	●	16	90	27	34	50	10
BT40-SRC18-90	●	18	90	33	42	50	10
BT40-SRC20-90	○	20	90	33	42	52	10
BT40-SRC25-100	○	25	100	44	53	58	10
BT40-SRC32-100	○	32	100	44	53	58	10
BT50-SRC4-100	○	4	100	14	22	20	5
BT50-SRC5-100	○	5	100	16	22	20	5
BT50-SRC6-100	○	6	100	21	27	36	10
BT50-SRC8-100	○	8	100	21	27	36	10
BT50-SRC10-100	○	10	100	24	32	41	10
BT50-SRC12-100	○	12	100	24	32	47	10
BT50-SRC14-100	○	14	100	27	34	47	10
BT50-SRC16-100	○	16	100	27	34	50	10
BT50-SRC18-110	○	18	110	33	42	50	10
BT50-SRC20-110	○	20	110	33	42	52	10
BT50-SRC25-120	○	25	120	44	53	58	10
BT50-SRC32-120	○	32	120	44	53	62	10

● Stock ○ Available upon Order

Turning inserts

External turning

Internal turning

Grooving & parting

Threading

Milling

Boring & drilling

Tool holder

Solid carbide end mills

Solid carbide drill & taps

Technical information

Turning inserts

External turning

Internal turning

Grooving & parting

Threading

Milling

Boring & drilling

Tool holder

Solid carbide end mills

Solid carbide drill & taps

Technical information

BT Hydraulic Chuck

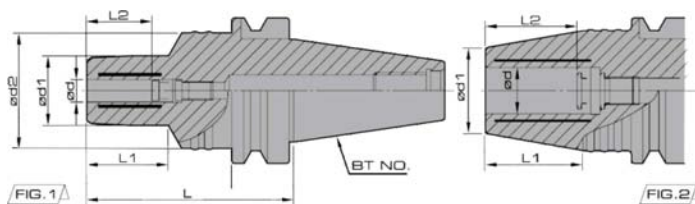

Ordering Code	Stock	Size(mm)					
		dm	D1	D2	L1	L	
BT30-HC06-80	○	06	28	50	35	80	-
BT30-HC08-80	○	08	30	50	35	80	-
BT30-HC10-80	○	10	32	50	35	80	-
BT30-HC12-90	●	12	35	50	43	90	HC12
BT30-HC16-95	●	16	38	50	51	95	-
BT30-HC20-95	●	20	42	50	52	95	HC20
BT40-HC06-85	○	06	28	50	35	85	-
BT40-HC08-85	○	08	30	50	35	85	-
BT40-HC10-85	○	10	32	50	35	85	-
BT40-HC12-90	●	12	35	50	43	90	HC12
BT40-HC16-95	●	16	38	50	51	95	-
BT40-HC20-95	●	20	42	50	52	95	HC20
BT40-HC25-115	●	25	57	70	63	115	-
BT50-HC12-100	●	12	35	50	43	100	HC12
BT50-HC16-105	●	16	38	50	51	105	-
BT50-HC20-105	●	20	42	50	52	105	HC20
BT50-HC25-120	●	25	57	70	63	120	-
BT50-HC32-120	●	32	64	70	65	120	HC32

MX Collet Chuck

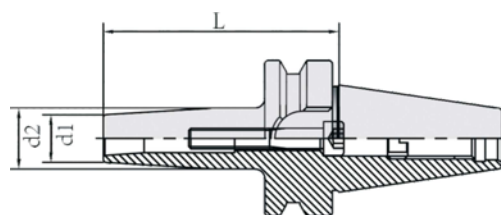

Ordering Code	Stock	Clamping Range	L	L1	D	
BT30-MX8-90	○	2-8	90	36	20	MX8
BT30-MX12-105	○	4-12	105	35	30	MX12
BT40-MX8-85	○	2-8	85	36	20	MX8
BT40-MX8-120	○	2-8	120	43	20	MX8
BT40-MX12-90	○	4-12	90	35	30	MX12
BT50-MX8-105	○	2-8	105	40	20	MX8
BT50-MX8-135	○	2-8	135	43	20	MX8
BT50-MX8-165	○	2-8	165	43	20	MX8
BT50-MX12-105	○	4-12	105	35	30	MX12

● Stock ○ Available upon Order

TER Tension And Compression Taper Holder BT □-TER □-L1

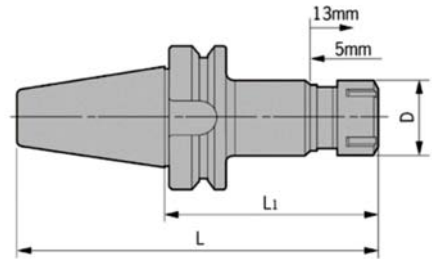

Ordering Code	Stock	L	L1	D	Range	Suitable Collet
BT30-TER16-75	●	123.4	75	28	M3-M10	ER16
BT30-TER20-90	●	138.4	90	34	M3-M10	ER20
BT40-TER16-120	●	185.4	120	28	M3-M10	ER16
BT40-TER20-100	●	165.4	100	34	M3-M17	ER20
BT40-TER32-120	●	185.4	120	50	M3-M20	ER32
BT50-TER16-120	●	221.8	120	28	M3-M10	ER16
BT50-TER20-100	●	201.8	100	24	M3-M17	ER20
BT50-TER32-120	●	221.8	120	50	M3-M20	ER32

TPM Quick Change Tension And Compression Taper Holder BT □-TPM □

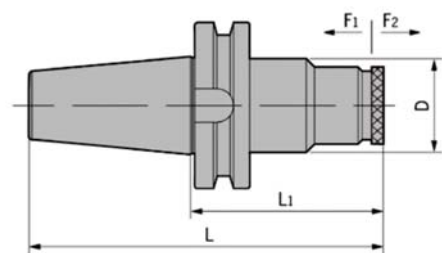

Ordering Code	Stock	L	L1	d	Range	Expansion Capaci	
						F1	F2
BT30-TPM316	●	162	111.6	50	M3-16	6	12
BT40-TPM316	●	168	101	50	M3-16	6	12
BT40-TPM830	○	208	141	66	M8-M30	12.5	12.5
BT50-TPM316	●	222.8	118	50	M3-16	6	12
BT50-TPM830	●	235	130.2	66	M8-M30	12.5	12.5

● Stock ○ Available upon Order

Turning inserts

External turning

Internal turning

Grooving & parting

Threading

Milling

Boring & drilling

Tool holder

Solid carbide end mills

Solid carbide drill & taps

Technical information

Turning inserts

External turning

Internal turning

Grooving & parting

Threading

Milling

Boring & drilling

Tool holder

Solid carbide end mills

Solid carbide drill & taps

Technical information

Taper Chuck BT □-L1 □-C

Technical specifications

Model	Stock	d	D	L1	Range
TPM316	●	32	19	21.5	M3-M16
TPM830	●	51.5	31	36	M8-M22



Taper chuck specifications table

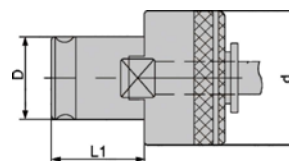

TPC316

JIS	Φd	□	ISO	Φd	□	DIN371	Φd	□	DIN376	Φd	□
TPC316 M03 W1/8	4	3.2	TPC316 M03	3.15	2.5	TPC316 M03	3.5	2.7	TPC316 M03	2.2	-
TPC316 M04	5	4	TPC316 M04	4	3.15	TPC316 M04	4.5	3.4	TPC316 M04	2.8	2.1
TPC316 M05 W3/16	5.5	4.5	TPC316 M05	5	4	TPC316 M05	6	4.9	TPC316 M05	3.5	2.7
TPC316 M06 W1/4	6	4.5	TPC316 M06	6.3	5	TPC316 M06	6	4.9	TPC316 M06	4.5	3.4
TPC316 M08	6.2	5	TPC316 M08	8	6.3	TPC316 M08	8	6.2	TPC316 M08	6	4.9
TPC316 M10 W3/8	7	5.5	TPC316 M10	10	8	TPC316 M10	10	8	TPC316 M10	7	5.5
TPC316 M12	8.5	6.5	TPC316 M12	9	7.1				TPC316 M12	9	7
TPC316 M14	10.5	8	TPC316 M14	11.2	9				TPC316 M14	11	9
TPC316 M16	12.5	10	TPC316 M16	12.5	10				TPC316 M16	12	9
TPC316 W5/16	6.1	5									
TPC316 W7/16 PT1/8	8	6									
TPC316 W1/2	9	7									
TPC316 W5/8	12	9									
TPC316 PT1/4	11	9									

TPC830

JIS	Φd	□	ISO	Φd	□	DIN371	Φd	□	DIN376	Φd	□
TPC830 M08	6.2	5	TPC830 M08	8		TPC830 M08	8	6.2	TPC830 M08	6	4.9
TPC830 M10 W3/8	7	5.5	TPC830 M10	10		TPC830 M10	10	8	TPC830 M10	7	5.5
TPC830 M12	8.5	6	TPC830 M12	9					TPC830 M12	9	7
TPC830 M14	10.5	8	TPC830 M14	11.2					TPC830 M14	11	9
TPC830 M16	12.5	10	TPC830 M16	12.5					TPC830 M16	12	9
TPC830 M18 W3/4 PT3/8	14	11	TPC830 M18	14					TPC830 M18	14	11
TPC830 M20	15	12	TPC830 M20	14					TPC830 M20	16	12
TPC830 M22 W7/8	17	13	TPC830 M22	16					TPC830 M22	18	14.5
TPC830 M24	19	15	TPC830 M24	18					TPC830 M24	18	14.5
TPC830 M27 W1 PT5/8	20	15	TPC830 M27	20					TPC830 M27	20	16
TPC830 M30 PT3/4	23	17	TPC830 M30	20					TPC830 M30	22	18
TPC830 W5/16	6.1	5	TPC830 PT1/2	16							
TPC830 W7/16 PT1/8	8	6									
TPC830 M1/2	9	7									
TPC830 W5/8	12	9									
TPC830 PT1/4	11	9									
TPC830 PT1/2	18	14									

● Stock ○ Available upon Order

Stock Collet Chuck BT □-SK□-L1

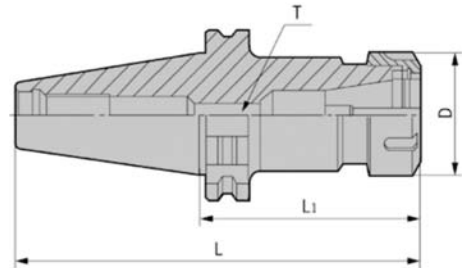

Ordering Code	Stock	Capacity	L	L1	D	Collet	Nut	Wrench
SK40-ER11-70	●	0,5-7	138.4	70	19	ER11	ER11-A	OW/ER11
-100	●		168.4	100	19			
SK40-ER16-70	●	1-10	138.4	70	28	ER16	ER16-A	OW/ER16
-100	●		168.4	100	28			
-150	●		218.4	150	28			
SK40-ER20-70	●	2-13	138.4	70	34	ER20	ER20-A	OW/ER20
-100	●		168.4	100	34			
-150	●		218.4	150	34			
SK40-ER25-70	●	2-16	138.4	70	42	ER25	ER25-UM	UW/ER25
-100	●		168.4	100	42			
-150	●		218.4	150	42			
SK40-ER32-70	●	3-20	138.4	70	50	ER32	ER32-UM	UW/ER32
-100	●		168.4	100	50			
-150	●		218.4	150	50			
SK40-ER40-80	●	3-26	148.4	80	63	ER40	ER40-UM	UW/ER40
-100	●		168.4	100	63			
-150	●		218.4	150	63			
SK50-ER16-70	●	1-10	171.8	70	28	ER16	ER16-A	OW/ER16
-100	●		201.8	100	28			
-150	●		251.8	150	28			
SK50-ER20-70	●	2-13	171.8	70	34	ER20	ER20-A	OW/ER20
-100	●		201.8	100	34			
-150	●		251.8	150	34			
SK50-ER25-70	●	2-16	171.8	70	42	ER25	ER25-UM	UW/ER25
-100	●		201.8	100	42			
-150	●		251.8	150	42			
SK50-ER32-70	●	3-20	171.8	70	50	ER32	ER32-UM	UW/ER32
-100	●		201.8	100	50			
-150	●		251.8	150	50			
SK50-ER40-80	●	3-26	171.8	80	63	ER40	ER40-UM	UW/ER40
-100	●		201.8	100	63			
-150	●		251.8	150	63			
-200	●		301.8	200	63			

● Stock ○ Available upon Order

Turning inserts

External turning

Internal turning

Grooving & parting

Threading

Milling

Boring & drilling

Tool holder

Solid carbide end mills

Solid carbide drill & taps

Technical information

SK Shank Face Mill Holder SK □-FMB□-L1

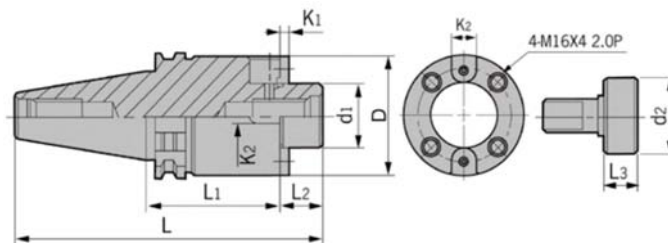

Ordering Code	Stock	d1	d2	D	L	L1	L2	K1	K2	T
SK40-FMB22-45	●	22	26	48	129.9	45	16.5	4.8	10	M10X30
-60	●				144.9	60				
-100	●				184.9	100				
-150	●				234.9	150				
SK40-FMB27-45	●	27	33	60	131.9	45	18.5	5.8	12	M12X30
-60	●				146.9	60				
-100	●				186.9	100				
-150	●				236.9	150				
SK40-FMB32-60	●	32	41	62	150.4	60	22	6.8	14	M16X35
-100	●				190.4	100				
-150	●				240.4	150				
-200	●				290.4	200				
SK40-FMB40-60	●	40	48	80	153.4	60	25	8	16	M16X35
-100	●				193.4	100				
-150	●				243.4	150				
-200	●				293.4	200				
SK50-FMB22-60	●	22	26	48	178.25	60	16.5	4.8	10	M10X30
-100	●				218.25	100				
-150	●				268.25	150				
-200	●				318.25	200				
SK50-FMB27-60	●	27	33	60	180.25	60	18.5	5.8	12	M12X30
-100	●				220.25	100				
-150	●				270.25	150				
-200	●				320.25	200				
SK50-FMB32-60	●	32	41	73	183.75	60	22	6.8	14	M16X35
-100	●				223.75	100				
-150	●				273.75	150				
-200	●				333.75	200				
SK50-FMB40-60	●	40	48	80	186.75	60	25	8	16	M16X35
-100	●				226.75	100				
-150	●				276.75	150				
-200	●				326.75	200				

Note:1. When order center cooling or flange cooling, please specify.

● Stock ○ Available upon Order

SK Shank SLN Side Lock End Mill Holder SK □-SLN□-L1

- SK taper shank is in conformity with At3 standard
- Tolerance H5 for inner bore d
- Default balancing design

DIN68971/DIN1835

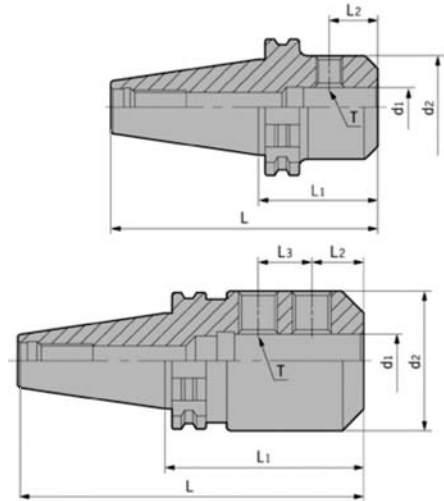

Ordering Code	Stock	Type	L	L1	H1	H2	M	D	d
SK30-SLN6-50	●	Fig.1	97.8	50	18	-	M6	25	6
SK30-SLN8-50	●	Fig.1			20		M8	28	8
SK30-SLN10-50	●	Fig.1			22.5		M10	35	10
SK30-SLN12-50	●	Fig.1					M12	42	12
SK30-SLN16-63	●	Fig.1	110.8	63		-	M14	48	16
SK30-SLN20-63	●	Fig.1					M16	52	20
SK40-SLN6-50	●	Fig.1	118.4	50	18	-	M6	25	6
SK40-SLN8-50	●	Fig.1			20		M8	28	8
SK40-SLN10-50	●	Fig.1			22.5		M10	35	10
SK40-SLN12-50	●	Fig.1					M12	42	12
SK40-SLN16-63	●	Fig.1	131.4	63	24	-	M14	48	16
SK40-SLN20-63	●	Fig.1			25		M16	52	20
SK40-SLN25-100	●	Fig.2	168.4	100	24	25	M18	65	25
SK40-SLN32-100	●	Fig.2			24	28	M20	72	32
SK50-SLN6-63	●	Fig.1	164.75	63	18	-	M6	25	6
SK50-SLN8-63	●	Fig.1			20		M8	28	8
SK50-SLN10-63	●	Fig.1			22.5		M10	35	10
SK50-SLN12-63	●	Fig.1			24		M12	42	12
SK50-SLN16-63	●	Fig.1			25		M14	48	16
SK50-SLN20-63	●	Fig.1					M16	52	20
SK50-SLN25-80	●	Fig.2	181.75	80	24	25	M18	65	25
SK50-SLN32-100	●	Fig.2	201.75	100		28	M20	72	32
SK50-SLN40-100	●	Fig.2			30	32	M20	90	40
SK50-SLN42-100	●	Fig.2			30	32	M20	100	42

Note:1. We can provide dynamic balabce G6.3/12000rpm, Price would be advanced.

● Stock ○ Availie upon Order

Turning inserts

External turning

Internal turning

Grooving & parting

Threading

Milling

Boring & drilling

Tool holder

Solid carbide end mills

Solid carbide drill & taps

Technical information

ER Collet Chuck DIN69893

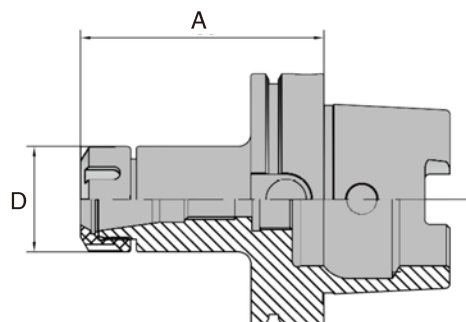

Ordering Code	Stock	Capacity	A	D	
HSK63A-ER16-100	●	1-10	100	32	ER16
HSK63A-ER20-100	●	1-12	100	38	ER20
HSK63A-ER25-100	●	2-16	100	42	ER25
HSK63A-ER32-100	●	2-20	100	50	ER32
HSK63A-ER16-160	●	1-10	160	32	ER16
HSK63A-ER20-160	●	1-12	160	38	ER20
HSK63A-ER25-160	●	2-16	160	42	ER25
HSK63A-ER32-160	●	2-20	160	50	ER32
HSK100A-ER32-100	●	2-20	100	50	ER32

End Mill Holder Weldon DIN69893

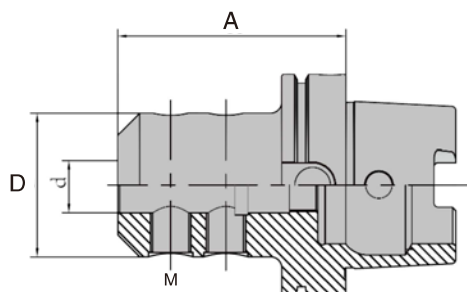

Ordering Code	Stock	d	A	D	M
HSK63A-SLA16-80	●	16	80	48	M14
HSK63A-SLA20-80	●	20	80	52	M16
HSK63A-SLA25-110	●	25	110	65	M18
HSK63A-SLA32-110	●	32	110	72	M20
HSK63A-SLA40-125	●	40	125	80	M20
HSK100A-SLA16-100	●	16	100	48	M14
HSK100A-SLA20-100	●	20	100	52	M16
HSK100A-SLA25-100	●	25	100	65	M18
HSK100A-SLA32-100	●	32	100	72	M20
HSK100A-SLA40-105	●	40	105	80	M20

● Stock ○ Available upon Order

Turning inserts

External turning

Internal turning

Grooving & parting

Threading

Milling

Boring & drilling

Tool holder

Solid carbide end mills

Solid carbide drill & taps

Technical information

FMB Face Mill Holder

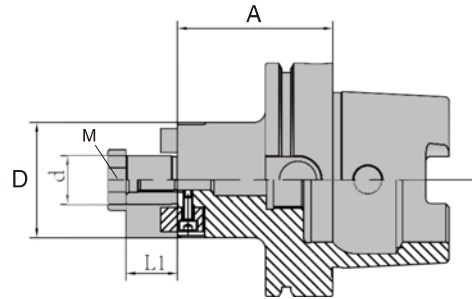

Ordering Code	Stock	d	A	L1	D	M
HSK50-FMB16-50	●	16	50	17	38	M8X30
HSK50-FMB22-60	●	22	60	19	48	M10X30
HSK50-FMB27-60	●	27	60	21	58	M12X30
HSK50-FMB32-60	●	32	60	24	78	M16X35
HSK63-FMB16-50	●	16	50	17	38	M8X30
HSK63-FMB22-50	●	22	50	19	48	M10X30
HSK63-FMB27-60	●	27	60	21	58	M12X30
HSK63-FMB32-60	●	32	60	24	78	M16X35
HSK63-FMB40-60	●	40	60	27	88	M16X35
HSK63-FMB16-100	●	16	100	17	38	M8X30
HSK63-FMB22-100	●	22	100	19	48	M10X30
HSK63-FMB27-100	●	27	100	21	58	M12X30
HSK63-FMB32-100	●	32	100	24	78	M16X35
HSK63-FMB40-100	●	40	100	27	88	M16X35
HSK80-FMB22-50	●	22	50	19	48	M10X30
HSK80-FMB27-50	●	27	50	21	58	M12X30
HSK80-FMB32-60	●	32	60	24	78	M16X35
HSK80-FMB40-60	●	40	60	27	88	M16X35
HSK100-FMB22-50	●	22	50	19	48	M10X30
HSK100-FMB27-50	●	27	50	21	58	M12X30
HSK100-FMB32-50	●	32	60	24	78	M16X35
HSK100-FMB40-60	●	40	60	27	88	M16X35
HSK100-FMB60-70	●	60	70	40	130	M16X35

● Stock ○ Available upon Order

Turning inserts

External turning

Internal turning

Grooving & parting

Threading

Milling

Boring & drilling

Tool holder

Solid carbide end mills

Solid carbide drill & taps

Technical information

Micro compensation tapping tool holder series

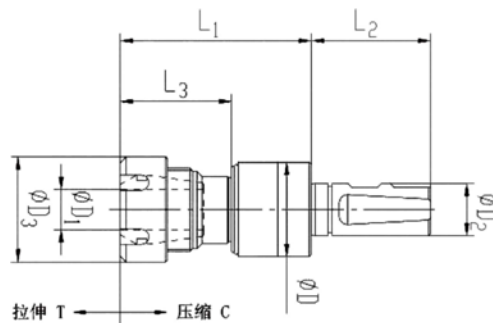

• ERNuts S type for the internal cooling type, A type for the cold type. Unit: mm

Ordering Code	Stock	ERJacket	φ D	φ D1	φ D2	φ D3	L1	L2	L3	C	T	Applicable taps
VLERS20-C25	●	ER20	34	4.5-10	25	34	68	57	45	0.5	0.5	M4-M12 (Nr.8-7/16)
VLERS32-C25	●	ER32	45	4.5-16	25	50	90	57	51	0.5	0.5	

Floating knife series

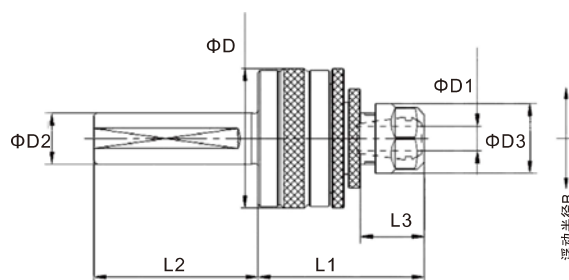

Unit: mm

Ordering Code	Stock	ERJacket	φ D1	φ D2	φ D	φ D3	L1	L2	L3	R (MAX)
SV-FTER20-D25	●	ER20	3-13	25	68	34	80	80	30	0.5

● Stock ○ Available upon Order

ER Collet Chuck Holder

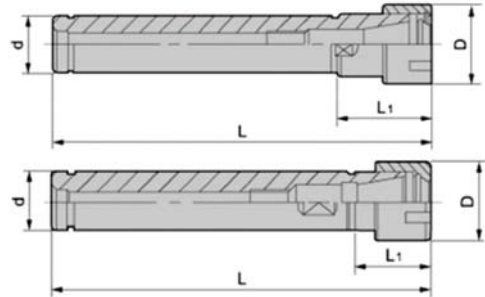

Ordering Code	Stock	D	d	L1	L	Nut	Wrench	Collet
C8-ER8M-55	●	12	8	24	79	CNM-ER08	ER08	ER08
C10-ER8M-180	●	12	10	17	197			
C12-ER8M-120	●	12	12	17	137			
C12-ER8M-180	●			17	197			
C12-ER11M-80	●	16	12	26.5	106.5	CNM-ER11	ER11M	ER11
C16-ER11M-100	●	0	16	18.5	118.5			
C16-ER11M-140	●	0	16	18.5	158.5			
C16-ER16M-80	●	23	16	37	117	CNM-ER16	ER16M	ER16
C20-ER16M-100	●	23	20	25	125			
C20-ER16M-160	●	23	20	25	185			
C20-ER20M-100	●	28	20	40	140	CNM-ER20	ER20M	ER20
C20-ER20M-150	●	28	20	40	190			
C20-ER20M-180	●	28	20	40	220			
C25-ER20M-140	●	28	25	28	168			
C20-ER25M-100	●	35	20	40	140	CNM-ER25	ER25M	ER25
C20-ER16-100	●	28	20	30	130	CAN-ER16	ER16A	ER16
C20-ER16-150	●	28	20	30	180			
C20-ER20-100	●	34	20	36	136	CAN-ER20	ER20A	ER20
C20-ER20-150	●	34	20	36	186			
C20-ER20-170	●	34	20	36	206			
C20-ER25-100	●	42	20	46	146	CAN-ER25	ER25UM	ER25
C20-ER25-150	●	42	20	46	196			
C25-ER16-100	●	28	25	30	130	CAN-ER16	ER16A	ER16
C25-ER16-150	●	28	25	30	180			
C25-ER20-150	●	34	25	36	186	CAN-ER20	ER20A	ER20
C25-ER25-100	●	42	25	46	146	CAN-ER25	ER25UM	ER25
C25-ER25-150	●	42	25	46	196			
C25-ER32-80	●	50	25	54	134	CAUM-ER32	ER32UM	ER32
C32-ER25-60	●	42	32	46	106	CAUM-ER25	ER25UM	ER25
C32-ER32-100	●	50	32	54	154	CAUM-ER32	ER32UM	ER32
C32-ER40-100	●	63	32	55	155	CAUM-ER40	ER40UM	ER40
C40-ER32-100	●	50	40	54	154	CAUM-ER32	ER32UM	ER32
C40-ER40-100	●	63	40	55	155	CAUM-ER40	ER40UM	ER40

● Stock ○ Available upon Order

Turning inserts

External turning

Internal turning

Grooving & parting

Threading

Milling

Boring & drilling

Tool holder

Solid carbide end mills

Solid carbide drill & taps

Technical information

ER Collet

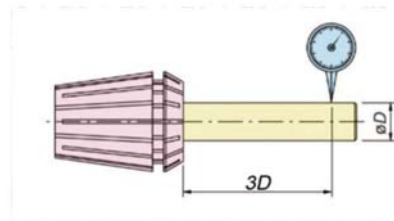
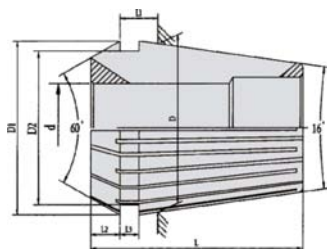

Ordering Code	Stock	DH7	D	D1	D2	L	L1	L2	L3	Elastic shrinkage
ER8	●	1.0–5.0	8	8.45	6.5	13.5	2.98	1.5	1.2	0.5
ER11	●	1.0–7.0	11	11.5	9.5	18	3.8	2.5	2	0.5
ER16	●	1.0–2.5	16	17	13.8	27.5	27.5	4	2.7	0.5
		2.5–10.0	16	17	13.8	27.5	27.5	4	2.7	1
ER20	●	1.0–2.5	20	21	17.4	31.5	31.5	4.8	2.8	0.5
		2.5–13.0	20	21	17.4	31.5	31.5	4.8	2.8	1
ER25	●	1.0–2.5	25	26	22	34	34	5	3.1	0.5
		2.5–16.0	25	26	22	34	34	5	3.1	1
ER32	●	2.0–2.5	32	33	29.2	40	40	5.5	3.6	0.5
		2.5–20.0	32	33	29.2	40	40	5.5	3.6	1
ER40	●	3.0–26.0	40	41	36.2	46	46	7	4.1	1
ER50	●	6.0–10.0	50	52	46	60	60	8.5	5.5	1
		10.0–34.0	50	52	46	60	60	8.5	5.5	2

Sealed Collet with Slitting

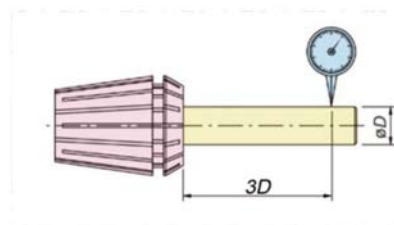
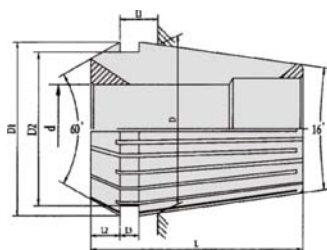

Ordering Code	Stock	DH7	D	D1	D2	L	L1	L2	L3	Elastic shrinkage
SER16	●	3.0–10.0	16	17	13.8	27.5	27.5	4	2.7	1
SER20	●	3.0–13.0	20	21	17.4	31.5	31.5	4.8	2.8	1
SER25	●	3.0–16.0	25	26	22	34	34	5	3.1	1
SER32	●	3.0–20.0	32	33	29.2	40	40	5.5	3.6	1
SER40	●	3.0–26.0	40	41	36.2	46	46	7	4.1	1

Clamping diameter	At the 4*D times the diameter of the clamping tool accuracy class			
J02308	ER	ER-A	ER-AA	ER-AA
J02311	0.02	0.01	0.006	0.003

According to the model number when ordering requirements plus accuracy class;
example: ER32-**AA

● Stock ○ Available upon Order

ER Straight Collet

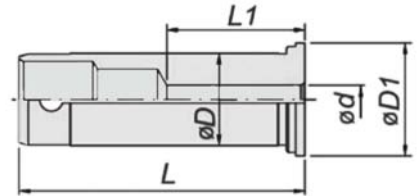

Ordering Code	Stock	Size(mm)		Model	Stock	Size(mm)		Ordering Code	Stock	Size(mm)	
		D	d			D	d			D	d
C20-06	●	20	6	C32-06	●	32	6	C42-06	●	42	6
C20-08	●		8	C32-08	●		8	C42-08	●		8
C20-10	●		10	C32-10	●		10	C42-10	●		10
C20-12	●		12	C32-12	●		12	C42-12	●		12
C20-16	●		16	C32-16	●		16	C42-16	●		16
	●			C32-20	●		20	C42-20	●		20
	●		C32-25	●	25	C42-25	●	25			
	●			●				C42-32	●	32	

SC Sealed Collet

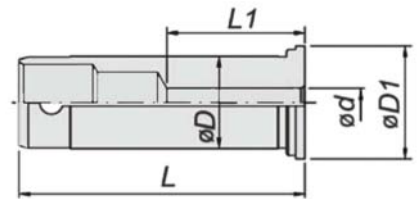

Ordering Code	Stock	Size(mm)		Model	Stock	Size(mm)		Ordering Code	Stock	Size(mm)	
		D	d			D	d			D	d
SC20-06	●	20	6	SC32-06	●	32	6	SC42-06	●	42	6
SC20-08	●		8	SC32-08	●		8	SC42-08	●		8
SC20-10	●		10	SC32-10	●		10	SC42-10	●		10
SC20-12	●		12	SC32-12	●		12	SC42-12	●		12
SC20-16	●		16	SC32-16	●		16	SC42-16	●		16
	●			SC32-20	●		20	SC42-20	●		20
	●		SC32-25	●	25	SC42-25	●	25			
	●			●				SC42-32	●	32	

● Stock ○ Available upon Order

Turning inserts

External turning

Internal turning

Grooving & parting

Threading

Milling

Boring & drilling

Tool holder

Solid carbide end mills

Solid carbide drill & taps

Technical information

- Turning inserts
- External turning
- Internal turning
- Grooving & parting
- Threading
- Milling
- Boring & drilling
- Tool holder
- Solid carbide end mills
- Solid carbide drill & taps
- Technical information

SKS Collet

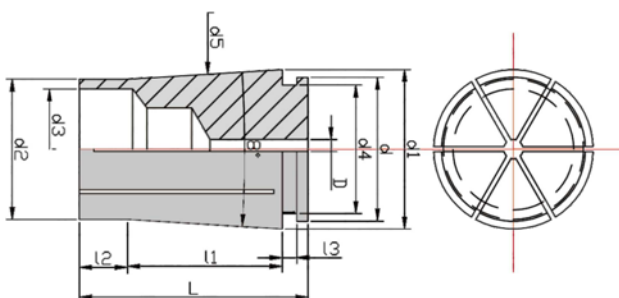

Ordering Code	Stock	L	l1	l2	l3	d	d1	d2	d3	d4	d5
SK06	●	25.7	17.5	4	2.4	9.26	10.5	7.5	6	7.8	9.964
SK10	●	32	22	5	2.5	13.7	15.6	12	10	12	15.013
SK16	●	46	32	8	2.8	21	24.6	18.8	16	19	23.939
SK25	●	58	43	8.5	3.6	31	35.6	28.9	25.5	28.2	35.029

Ordering Code	D
SK06	2, 2.5, 3, 3.5, 4, 4.5, 5, 5.5, 6
SK10	2, 2.5, 3, 3.5, 4, 4.5, 5, 5.5, 6, 6.5, 7, 7.5, 8, 8.5, 9, 9.5, 10
SK16	3, 3.5, 4, 4.5, 5, 5.5, 6, 6.5, 7, 7.5, 8, 8.5, 9, 9.5, 10, 10.5, 11, 11.5, 12, 12.5, 13, 13.5, 14, 14.5, 15, 15.5, 16
SK25	6, 8, 10, 12, 14, 16, 16.5, 17, 17.5, 18, 18.5, 19, 19.5, 20, 20.5, 21, 21.5, 22, 22.5, 23, 23.5, 24, 24.5, 25

MX Collet

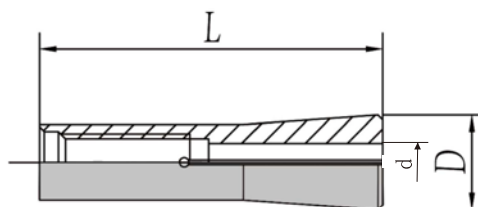

Ordering Code	Stock	d	Standard	P Class	D	L
MX6-2,3,4,5,6,3,175	●	2-6	0.005	0.003	9.6	36
MX8-3,4,5,6,8	●	3-8	0.005	0.003	15	45
MX10-3,4,5,6,8,10	●	3-10	0.005	0.003	16	52
MX12-3,4,5,8,10,12	●	3-12	0.005	0.003	22	57

● Stock ○ Available upon Order

BT Pull Studs

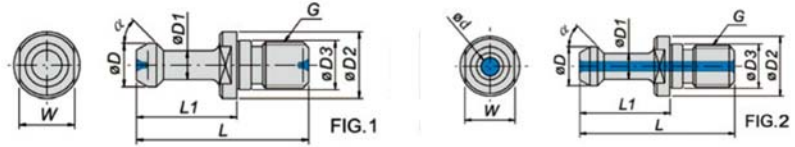

Ordering Code	Figure	Stock	D	D1	D2	D3	L	L1	a	G	W
BT30-45°	Fig.1	●	11	7	16.5	12.5	43	23	45°	M12	13
BT30-60°		●							60°		
BT40-45°		●	15	10	23	17	60	35	45°	M16	19
BT40-60°		●							60°		
BT40-90°		●							90°		
BT50-45°	Fig.2	●	23	17	38	25	85	45	45°	M24	30
BT50-60°		●							45°		
BT40-45° -S		●	15	10	23	17	60	35	45°	M16	19
BT40-60° -S		●							60°		
BT40-90° -S		●							90°		
BT50-45° -S	●	23	17	38	25	85	45	45°	M24	30	
BT50-60° -S	●							45°			
BT50-90° -S	●							45°			

JT Pull Studs

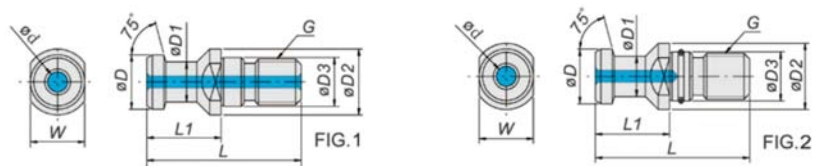

Ordering Code	Figure	Stock	D	D1	D2	D3	d	L	L1	W	G
SK40-A	Fig.1	●	19	14	23	17	7	54	26	19	M16
SK50-A		●	28	21	36	25	11.5	74	34	30	M24
SK40-B	Fig.2	●	19	14	23	17	7	54	26	19	M16
SK50-B		●	28	21	36	25	11.5	74	34	30	M24

● Stock ○ Available upon Order

Turning inserts

External turning

Internal turning

Grooving & parting

Threading

Milling

Boring & drilling

Tool holder

Solid carbide end mills

Solid carbide drill & taps

Technical information

ER Clamping Nuts (DIN6499)

ER-M M Type Clamping Nuts

Part NO.	M	Fig.	ØD	L	Max.Tightening Torque Nm
CNM-ER08	M10*0.75P	1	12	10.8	10
CNM-ER11	M13*0.75P		16	12	30
CNM-ER16	M19*1.00P		22	18	70
CNM-ER20	M24*1.00P		28	19	100

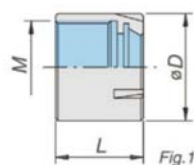

ER-SH High Speed Balanced Clamping Nuts

Part NO.	M	Fig.	ØD	L	H	Max.Tightening Torque Nm
CAN-ER11	M14*0.75P	2	19	11.3	17	30
CAN-ER16	M22*1.50P		28	17.5	25	70
CAN-ER20	M25*1.50P		34	19	30	100
CAUM-ER16	M22*1.50P	3	32	17	-	70
CAUM-ER20	M25*1.50P		35	19		100
CAUM-ER25	M32*1.50P		42	20		130
CAUM-ER32	M40*1.50P		50	23		170
CAUM-ER40	M50*1.50P		63	25	220	

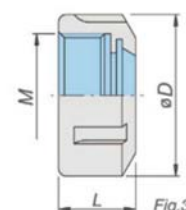
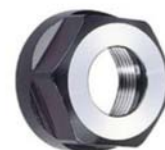
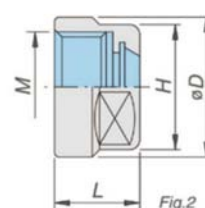

Clamping Nuts

NR Nuts

Part NO.	M	ØD	L	Max.Tightening Torque Nm
GSK 06	M15.5*1.00P	20.0	21.5	30
GSK 10	M21.5*1.00P	27.1	24	40
GSK 16	M32.0*1.50P	40.0	31	60
GSK 25	M45.0*1.50P	55.0	37.5	100

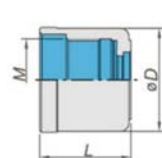

NR-WD Nuts

Part NO.	M	ØD	H	L	Max.Tightening Torque Nm
SK 10M	M21.5*1.00P	27.5	25.4	17	40
SK 16M	M32.0*1.50P	40.0	-	24	60

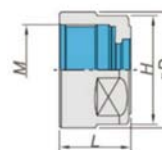

Turning inserts

External turning

Internal turning

Grooving & parting

Threading

Milling

Boring & drilling

Tool holder

Solid carbide end mills

Solid carbide drill & taps

Technical information

Wrenches

Part N0.	A	B	Nuts
W-ER 8M	12.8	75	CNM-ER08
W-ER 11M	16.8	90	CNM-ER11
W-ER 16M	22.8	110	CNM-ER16
W-ER 20M	29	120	CNM-ER20

Part N0.	A	B	W	Nuts
W-ER 11A	32	95	17	CAN-ER11
W-ER 16A	44	145	25	CAN-ER16
W-ER 20A	52	170	30	CAN-ER20

Part N0.	ØD	B	Nuts
W-FK 04	Φ30-Φ33	135	ER16GM
W-FK 05	Φ34-Φ36	160	ER20GM
W-FK 06	Φ40-Φ42	170	NR16/ER25SH/NR16WD
W-FK 07	Φ44-Φ49	195	ER25GM
W-FK 08	Φ52-Φ55	210	C20/ER32SH
W-FK 09	Φ58-Φ62	230	CTH25/ER40SH/C25
W-FK 10	Φ68-Φ75	245	CTH32/C32
W-FK 11	Φ80-Φ93	270	ARH42

Part N0.	ØD	A	B	Nuts
W-ER 25UM	42	65	210	CAUM-ER25
W-ER 32UM	50	75	250	CAUM-ER32
W-ER 40UM	63	90	290	CAUM-ER40
W-ER 50UM	80	110	355	CAUM-ER50

High Speed Tooling Wrenches

Part N0.	ØD	B	Nuts
W-SK06	19.7	118	SK06
W-SK10	27.7		SK10
W-SK16	40	212	SK16
W-SK20	48		SK20
W-SK25	55		SK25

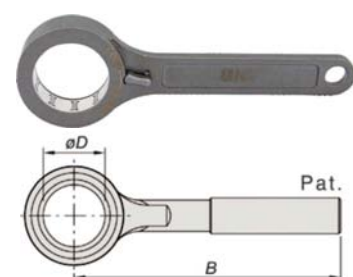
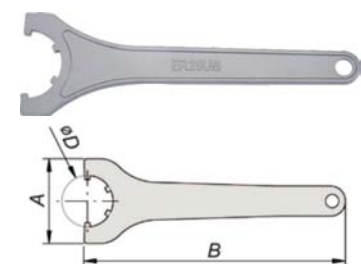
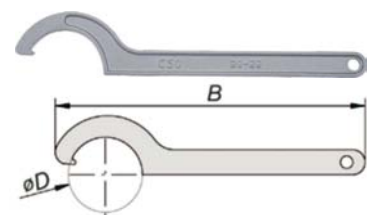
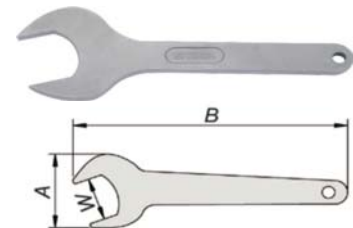
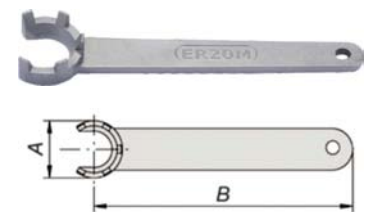

Turning inserts

External turning

Internal turning

Grooving & parting

Threading

Milling

Boring & drilling

Tool holder

Solid carbide end mills

Solid carbide drill & taps

Technical information



Solid carbide drills & taps



Solid Carbide End Mills Identification System

<p>P M K</p> <p>Steel, Cast Iron Stainless Steel Aluminium Alloy</p>	PD20	<p>PD20 Twist Drills for General Purpose</p> <ul style="list-style-type: none"> ● Suitable for drilling steel, stainless steel, cast iron, non-ferrous material. ● Stub chisel, excellent self-center capability. ● Radial point, smaller cutting resistance. ● Unique edge preparation, higher feed rate, higher efficiency.
<p>M S</p> <p>Stainless Steel Titanium Alloys</p>	MD20	<p>KD20 Twist Drills for Cast Iron</p> <ul style="list-style-type: none"> ● Suitable for drilling cast iron of automobile industry and other industries. ● Wave formed cutting lips provides lowered machining torque. ● Four margin, improves hole wall quality and accuracy. ● Increased Drilla point strength through optimized chisel edge.
<p>K</p> <p>Aluminium Alloy</p>	KD20	<p>MD20 Twist Drills for Stainless Steel</p> <ul style="list-style-type: none"> ● Suitable for drilling stainless steel. ● Excellent edge strength, excellent self-centering capability. ● Straight lips, precise edge preparation is adapted, reinforce the strength of edge. ● Small edge home, large black taper, reduce friction and torque impact.
<p>N</p> <p>Graphite</p>	ND25UF	<p>ND25UF Twist Drills for alloys</p> <ul style="list-style-type: none"> ● Suitable for drilling cast iron, silicon-aluminium alloys. ● Surface Roughness Ra1-2 ● Increased Drilla point strength through optimized chisel edge.
<p>H</p> <p>High Hardened Material</p>	HD15UF	<p>HD15UF Twist Drills for Hardened Steel</p> <ul style="list-style-type: none"> ● Suitable for drilling hardened steel. ● Large core thickness, small helix angle, high rigidity and strength. ● X-shaped Drills tip, excellent self-center capability. ● Radius Drills point, excellent hole wall quality.



PD20 A 3 N 0600



①

Shank Type	
A	DIN6535HA
E	DIN6535HE
B	DIN6535HB
Y	Continuous Parallel Shank

②

Drilling Depth	
3	Drilling Depth ≤ 3D
5	Drilling Depth ≤ 5D
90	90° Point Angle
120	120° Point Angle
145	145° Point Angle

③

Coolant Type	
C	Inner Cooling
N	External Cooling

④

Drills Diameter	
0325	Dia: Φ 3.25
0600	Dia: Φ 6.00
1200	Dia: Φ 12.00

Turning Inserts

External turning

Internal turning

Grooving & parting

Threading

Milling

Boring & drilling







Tool holder







Solid carbide end mills







Solid carbide drill & taps

Technical information

Guidelines to Icons

	Mark	Description
Shank		ISO Standard Shank
Coating		AlCrN Coating
		AlCrSiN Coating
		Nano Coating AlTiN
		Nano Coating AlTiN/TiSiN
		Ultra Fine Grain Diamond Coating

	Mark	Description
Drilling Depth		The Maximum Depth of Drilling is 3D
		The Maximum Depth of Drilling is 5D
Drills Type		Twist Drills
		Twist Drills with Inner Cooling
		Straight Flute Drills
		Straight Flute Drills with Inner Cooling

	Mark	Description
Workpiece Material		Steels
		Stainless Steels
		Cast Iron
		Non-ferrous Materials
		Heat-resistant Super Alloys, Titanium Alloys
		High Hardened Materials

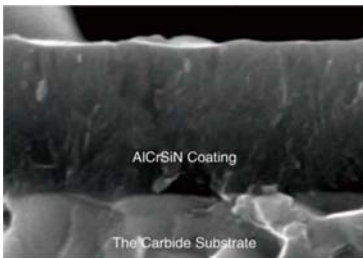

SEM Photograph of Coating

Universal High Performance Coating AlCrSiN Characteristics and Function

- Productivity increase due to significantly higher cutting speed and feed for applications in a wide range of materials. Significantly enhanced productivity.
- Particular design of structure brings good balance between toughness, thermo-shock stability and residual stress.

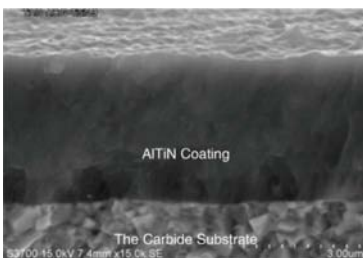

SEM Photograph of Coating

Nano Coating AlTiN Characteristics and Function

- High aluminum content provides excellent hot hardness and oxidation resistance.
- Special method optimizes the structure of coating, significantly improved stability, reducing the number of surface droplet.

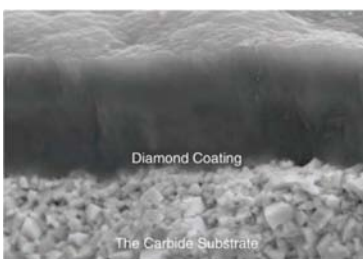

Cross-section Image

Ultra Fine Grain Diamond Coating Characteristics and Function

- High purity diamond coating, with hardness up to 80GPa.
- Ultra smooth and shiny surface, low coefficient friction.
- Suitable for finish machining nonferrous materials, such as graphite, aluminium, carbon fiber, ceramic, etc.

Self-Locked clamping system

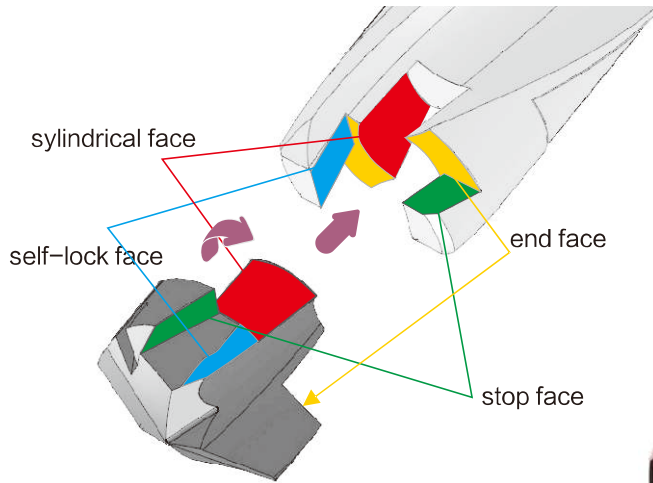

- Centering by cylindrical faces
- The cutting head can be self-locked with toolholder while inserted due to its seat elastic deformation
- Axial drill force is transferred to toolholder by end faces
- Drill torque is transferred to toolholder by stop faces

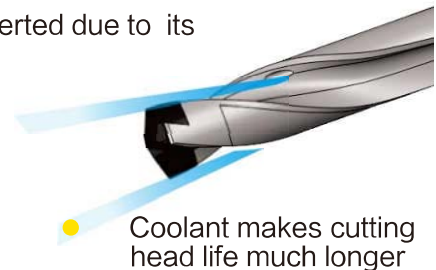

- Coolant makes cutting head life much longer

How to attach cutting heads



1

Remove dust using air blast



2

Turn lightly in a clockwise direction (Use gloves to protect your hand from any danger)

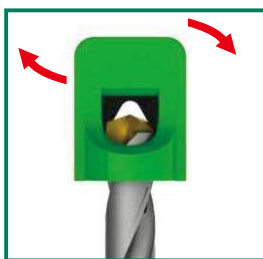

3

Turn the wrench in a clockwise direction slowly, then turn strongly while passing self-locked face until cutting head won't move



4

Complete

Cooling method

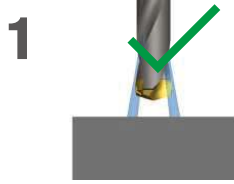

1

Suggest to select machine tools with inner cooling system

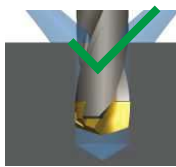

2

With outer cooling system, suggest to drill the hole size less than 3D diameter.

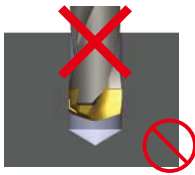

3

Do not dry cut

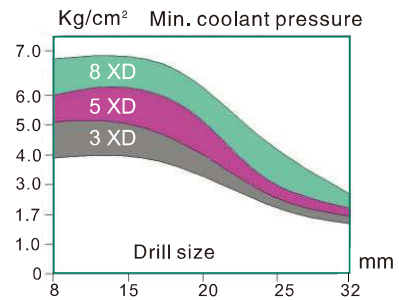
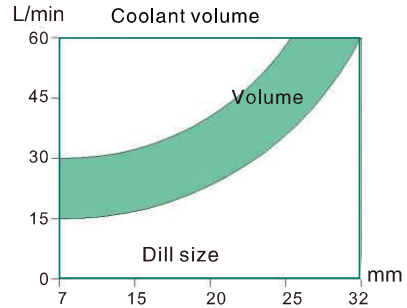

Usage precautions core deviation

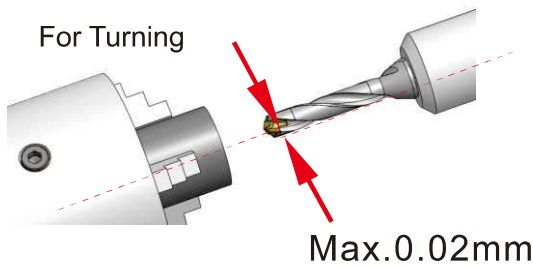

Set deviation amount under 0.02mm between the workpiece and the drill

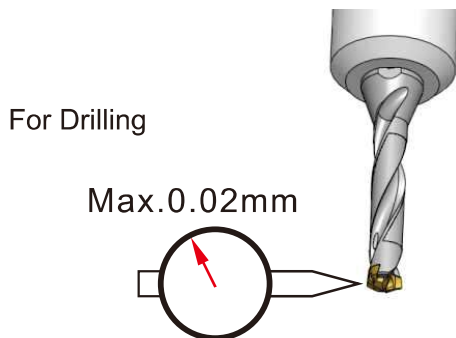

Do not use any arbor with a deformed attachment surface. Center of arbor deviation must be within 0.02mm

Indication of cutting head wear

a) Wear Limit

b) Power Restriction

(1) New cutting head
(2) Increase 25% for wore-out cutting head

c) Diameter Change

d) Surface Finish Deterioration

e) Vibration Noise Drastically Increases

Application

Application Recommendation	Workpiece Shape	Application Not Recommendation	Workpiece Shape
Flat Face Recommended		Hole Expansion Not Recommended	
Stacked Plates Recommended (absolutely don't move between plates)		Slanted Surface Not Recommended	
Concave Surface Recommended (reduce a half of feed rate as normal)		Half Cylindrical Not Recommended	
Pipe Material Recommended		Cored Hole Not Recommended	

Turning inserts

External turning

Internal turning

Grooving & parting

Threading

Milling

Boring & drilling

Tool holder

Solid carbide end mills

Solid carbide drill & taps

Technical information

Turning inserts

External turning

Internal turning

Grooving & parting

Threading

Milling

Boring & drilling

Tool holder

Solid carbide end mills

Solid carbide drill & taps

Technical information

PM/PR head



P270 ~P271

Dr II



P272 ~P273

Form ng tap



P274 ~P275

Cutt ng tap



P276

Plug gauge



P277

PM head



Recommend PM
Especially for less than 5D

PR head



Recommend PR
Especially for more than 5D

P		M	K	N
Low-carbon steels	Steel	Stainless Steel	Cast Iron	Aluminum Alloy

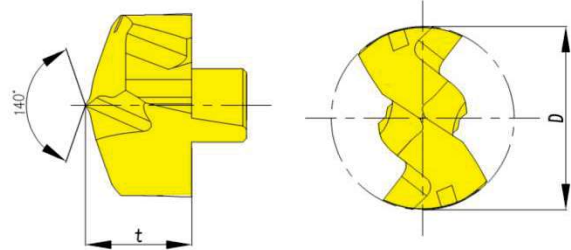

Order No.	Dimensions (mm)		TS4125	TS7912	Tool holders
	D	t			
MSQD-080-PM/PR	8.0	5.4	●	●	MSQD080-12
MSQD-081-PM/PR	8.1	5.4	○	○	
MSQD-082-PM/PR	8.2	5.4	○	○	
MSQD-083-PM/PR	8.3	5.4	○	○	
MSQD-084-PM/PR	8.4	5.4	○	○	
MSQD-085-PM/PR	8.5	5.4	●	●	
MSQD-086-PM/PR	8.6	5.4	○	○	
MSQD-087-PM/PR	8.7	5.4	○	○	
MSQD-088-PM/PR	8.8	5.4	○	○	
MSQD-089-PM/PR	8.9	5.4	○	○	
MSQD-090-PM/PR	9.0	5.8	●	●	MSQD090-12
MSQD-091-PM/PR	9.1	5.8	○	○	
MSQD-092-PM/PR	9.2	5.8	○	○	
MSQD-093-PM/PR	9.3	5.8	○	○	
MSQD-094-PM/PR	9.4	5.8	○	○	
MSQD-095-PM/PR	9.5	5.8	●	●	
MSQD-096-PM/PR	9.6	5.8	○	○	
MSQD-097-PM/PR	9.7	5.8	○	○	
MSQD-098-PM/PR	9.8	5.8	○	○	
MSQD-099-PM/PR	9.9	5.8	○	○	
MSQD-100-PM/PR	10.0	6.2	●	●	MSQD100-12
MSQD-101-PM/PR	10.1	6.2	○	○	
MSQD-102-PM/PR	10.2	6.2	○	○	
MSQD-103-PM/PR	10.3	6.2	○	○	
MSQD-104-PM/PR	10.4	6.2	○	○	
MSQD-105-PM/PR	10.5	6.2	●	●	
MSQD-106-PM/PR	10.6	6.2	○	○	
MSQD-107-PM/PR	10.7	6.2	○	○	
MSQD-108-PM/PR	10.8	6.2	○	○	
MSQD-109-PM/PR	10.9	6.2	○	○	
MSQD-110-PM/PR	11.0	6.6	●	●	MSQD110-12
MSQD-111-PM/PR	11.1	6.6	○	○	
MSQD-112-PM/PR	11.2	6.6	○	○	
MSQD-113-PM/PR	11.3	6.6	○	○	
MSQD-114-PM/PR	11.4	6.6	○	○	
MSQD-115-PM/PR	11.5	6.6	●	●	
MSQD-116-PM/PR	11.6	6.6	○	○	
MSQD-117-PM/PR	11.7	6.6	○	○	
MSQD-118-PM/PR	11.8	6.6	○	○	
MSQD-119-PM/PR	11.9	6.6	○	○	

Order No.	Dimensions (mm)		TS4125	TS7912	Tool holders
	D	t			
MSQD-120-PM/PR	12.0	7.0	●	●	MSQD120-12
MSQD-121-PM/PR	12.1	7.0	○	○	
MSQD-122-PM/PR	12.2	7.0	○	○	
MSQD-123-PM/PR	12.3	7.0	○	○	
MSQD-124-PM/PR	12.4	7.0	○	○	
MSQD-125-PM/PR	12.5	7.0	●	●	
MSQD-126-PM/PR	12.6	7.0	○	○	
MSQD-127-PM/PR	12.7	7.0	○	○	
MSQD-128-PM/PR	12.8	7.0	○	○	
MSQD-129-PM/PR	12.9	7.0	○	○	
MSQD-130-PM/PR	13.0	7.6	●	●	MSQD130-12
MSQD-131-PM/PR	13.1	7.6	○	○	
MSQD-132-PM/PR	13.2	7.6	○	○	
MSQD-133-PM/PR	13.3	7.6	○	○	
MSQD-134-PM/PR	13.4	7.6	○	○	
MSQD-135-PM/PR	13.5	7.6	●	●	
MSQD-136-PM/PR	13.6	7.6	○	○	
MSQD-137-PM/PR	13.7	7.6	○	○	
MSQD-138-PM/PR	13.8	7.6	○	○	
MSQD-139-PM/PR	13.9	7.6	○	○	
MSQD-140-PM/PR	14.0	8.1	●	●	MSQD140-12
MSQD-141-PM/PR	14.1	8.1	○	○	
MSQD-142-PM/PR	14.2	8.1	○	○	
MSQD-143-PM/PR	14.3	8.1	○	○	
MSQD-144-PM/PR	14.4	8.1	○	○	
MSQD-145-PM/PR	14.5	8.1	●	●	
MSQD-146-PM/PR	14.6	8.1	○	○	
MSQD-147-PM/PR	14.7	8.1	○	○	
MSQD-148-PM/PR	14.8	8.1	○	○	
MSQD-149-PM/PR	14.9	8.1	○	○	
MSQD-150-PM/PR	15.0	8.7	●	●	MSQD150-12
MSQD-151-PM/PR	15.1	8.7	○	○	
MSQD-152-PM/PR	15.2	8.7	○	○	
MSQD-153-PM/PR	15.3	8.7	○	○	
MSQD-154-PM/PR	15.4	8.7	○	○	
MSQD-155-PM/PR	15.5	8.7	●	●	
MSQD-156-PM/PR	15.6	8.7	○	○	
MSQD-157-PM/PR	15.7	8.7	○	○	
MSQD-158-PM/PR	15.8	8.7	○	○	
MSQD-159-PM/PR	15.9	8.7	○	○	

● Stock ○ Available upon Order

Turning inserts

External turning

Internal turning

Grooving & parting

Threading

Milling

Boring & drilling

Tool holder

Solid carbide end mills

Solid carbide drill & taps

Technical information

- Turning inserts
- External turning
- Internal turning
- Grooving & parting
- Threading
- Milling
- Boring & drilling
- Tool holder
- Solid carbide end mills
- Solid carbide drill & taps
- Technical information



Order No.	Dimensions (mm)		TS4125	TS7912	Tool holders
	D	t			
MSQD-160-PM/PR	16.0	9.3	●	●	MSQD160-12
MSQD-161-PM/PR	16.1	9.3	○	○	
MSQD-162-PM/PR	16.2	9.3	○	○	
MSQD-163-PM/PR	16.3	9.3	○	○	
MSQD-164-PM/PR	16.4	9.3	○	○	
MSQD-165-PM/PR	16.5	9.3	●	●	
MSQD-166-PM/PR	16.6	9.3	○	○	
MSQD-167-PM/PR	16.7	9.3	○	○	
MSQD-168-PM/PR	16.8	9.3	○	○	
MSQD-169-PM/PR	16.9	9.3	○	○	
MSQD-170-PM/PR	17.0	9.9	●	●	MSQD170-12
MSQD-171-PM/PR	17.1	9.9	○	○	
MSQD-172-PM/PR	17.2	9.9	○	○	
MSQD-173-PM/PR	17.3	9.9	○	○	
MSQD-174-PM/PR	17.4	9.9	○	○	
MSQD-175-PM/PR	17.5	9.9	●	●	
MSQD-176-PM/PR	17.6	9.9	○	○	
MSQD-177-PM/PR	17.7	9.9	○	○	
MSQD-178-PM/PR	17.8	9.9	○	○	
MSQD-179-PM/PR	17.9	9.9	○	○	
MSQD-180-PM/PR	18.0	10.5	●	●	MSQD180-12
MSQD-181-PM/PR	18.1	10.5	○	○	
MSQD-182-PM/PR	18.2	10.5	○	○	
MSQD-183-PM/PR	18.3	10.5	○	○	
MSQD-184-PM/PR	18.4	10.5	○	○	
MSQD-185-PM/PR	18.5	10.5	●	●	
MSQD-186-PM/PR	18.6	10.5	○	○	
MSQD-187-PM/PR	18.7	10.5	○	○	
MSQD-188-PM/PR	18.8	10.5	○	○	
MSQD-189-PM/PR	18.9	10.5	○	○	
MSQD-190-PM/PR	19.0	11.0	●	●	MSQD190-12
MSQD-191-PM/PR	19.1	11.0	○	○	
MSQD-192-PM/PR	19.2	11.0	○	○	
MSQD-193-PM/PR	19.3	11.0	○	○	
MSQD-194-PM/PR	19.4	11.0	○	○	
MSQD-195-PM/PR	19.5	11.0	●	●	
MSQD-196-PM/PR	19.6	11.0	○	○	
MSQD-197-PM/PR	19.7	11.0	○	○	
MSQD-198-PM/PR	19.8	11.0	○	○	
MSQD-199-PM/PR	19.9	11.0	○	○	
MSQD-200-PM/PR	20.0	11.6	●	●	MSQD190-12
MSQD-201-PM/PR	20.1	11.6	○	○	
MSQD-202-PM/PR	20.2	11.6	○	○	
MSQD-203-PM/PR	20.3	11.6	○	○	
MSQD-204-PM/PR	20.4	11.6	○	○	
MSQD-205-PM/PR	20.5	11.6	●	●	
MSQD-206-PM/PR	20.6	11.6	○	○	
MSQD-207-PM/PR	20.7	11.6	○	○	
MSQD-208-PM/PR	20.8	11.6	○	○	
MSQD-209-PM/PR	20.9	11.6	○	○	

Order No.	Dimensions (mm)		TS4125	TS7912	Tool holders
	D	t			
MSQD-210-PM/PR	21.0	12.1	●	●	MSQD120-12
MSQD-211-PM/PR	21.1	12.1	○	○	
MSQD-212-PM/PR	21.2	12.1	○	○	
MSQD-213-PM/PR	21.3	12.1	○	○	
MSQD-214-PM/PR	21.4	12.1	○	○	
MSQD-215-PM/PR	21.5	12.1	●	●	
MSQD-216-PM/PR	21.6	12.1	○	○	
MSQD-217-PM/PR	21.7	12.1	○	○	
MSQD-218-PM/PR	21.8	12.1	○	○	
MSQD-219-PM/PR	21.9	12.1	○	○	
MSQD-220-PM/PR	22.0	12.7	●	●	MSQD130-12
MSQD-221-PM/PR	22.1	12.7	○	○	
MSQD-222-PM/PR	22.2	12.7	○	○	
MSQD-223-PM/PR	22.3	12.7	○	○	
MSQD-224-PM/PR	22.4	12.7	○	○	
MSQD-225-PM/PR	22.5	12.7	●	●	
MSQD-226-PM/PR	22.6	12.7	○	○	
MSQD-227-PM/PR	22.7	12.7	○	○	
MSQD-228-PM/PR	22.8	12.7	○	○	
MSQD-229-PM/PR	22.9	12.7	○	○	
MSQD-230-PM/PR	23.0	13.3	●	●	
MSQD-231-PM/PR	23.1	13.3	○	○	
MSQD-232-PM/PR	23.2	13.3	○	○	
MSQD-233-PM/PR	23.3	13.3	○	○	
MSQD-234-PM/PR	23.4	13.3	○	○	
MSQD-235-PM/PR	23.5	13.3	●	●	
MSQD-236-PM/PR	23.6	13.3	○	○	
MSQD-237-PM/PR	23.7	13.3	○	○	
MSQD-238-PM/PR	23.8	13.3	○	○	
MSQD-239-PM/PR	23.9	13.3	○	○	
MSQD-240-PM/PR	24.0	13.9	●	●	
MSQD-241-PM/PR	24.1	13.9	○	○	
MSQD-242-PM/PR	24.2	13.9	○	○	
MSQD-243-PM/PR	24.3	13.9	○	○	
MSQD-244-PM/PR	24.4	13.9	○	○	
MSQD-245-PM/PR	24.5	13.9	●	●	
MSQD-246-PM/PR	24.6	13.9	○	○	
MSQD-247-PM/PR	24.7	13.9	○	○	
MSQD-248-PM/PR	24.8	13.9	○	○	
MSQD-249-PM/PR	24.9	13.9	○	○	
MSQD-250-PM/PR	25.0	14.5	●	●	
MSQD-251-PM/PR	25.1	14.5	○	○	
MSQD-252-PM/PR	25.2	14.5	○	○	
MSQD-253-PM/PR	25.3	14.5	○	○	
MSQD-254-PM/PR	25.4	14.5	○	○	
MSQD-255-PM/PR	25.5	14.5	●	●	
MSQD-256-PM/PR	25.6	14.5	○	○	
MSQD-257-PM/PR	25.7	14.5	○	○	
MSQD-258-PM/PR	25.8	14.5	○	○	
MSQD-259-PM/PR	25.9	14.5	○	○	
MSQD-260-PM	26.0	14.5	●	●	

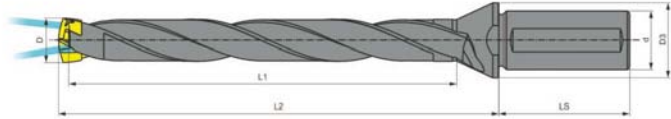

● Stock ○ Available upon Order

Drills (coolant through center)



code number	Applicable cutting head Dia. (mm)	Dimensions (mm)					Wrench
		d	D3	L1	Ls	D	
		d	D3	L1	Ls	D	
MSQD-080/089-12-5D	8.0~8.9	12	16	50	45	7.8	8-11.9
MSQD-090/099-12-5D	9.0~9.9	12	16	55	45	8.8	
MSQD-100/109-16-5D	10.0~10.9	16	20	60	48	9.8	
MSQD-110/119-16-5D	11.0~11.9	16	20	66	48	10.8	
MSQD-120/129-16-5D	12.0~12.9	16	20	71	48	11.8	12-16.9
MSQD-130/139-16-5D	13.0~13.9	16	20	77	48	12.8	
MSQD-140/149-16-5D	14.0~14.9	16	20	82	48	13.8	
MSQD-150/159-20-5D	15.0~15.9	20	25	88	50	14.8	
MSQD-160/169-20-5D	16.0~16.9	20	25	93	50	15.8	17-20.9
MSQD-170/179-20-5D	17.0~17.9	20	25	99	50	16.8	
MSQD-180/189-25-5D	18.0~18.9	25	32	104	56	17.8	
MSQD-190/199-25-5D	19.0~19.9	25	32	110	56	18.8	
MSQD-200/209-25-5D	20.0~20.9	25	32	115	56	19.8	21-26
MSQD-210/219-25-5D	21.0~21.9	25	32	121	56	20.8	
MSQD-220/229-25-5D	22.0~22.9	25	32	126	56	21.8	
MSQD-230/239-32-5D	23.0~23.9	32	42	132	60	22.8	
MSQD-240/249-32-5D	24.0~24.9	32	42	137	60	23.8	21-26
MSQD-250/259-32-5D	25.0~25.9	32	42	143	60	24.8	



code number	Applicable cutting head Dia. (mm)	Dimensions (mm)					Wrench
		d	D3	L1	Ls	D	
		d	D3	L1	Ls	D	
MSQD-080/089-12-8D	8.0~8.9	12	16	76	45	7.8	8-11.9
MSQD-090/099-12-8D	9.0~9.9	12	16	85	45	8.8	
MSQD-100/109-16-8D	10.0~10.9	16	20	93	48	9.8	
MSQD-110/119-16-8D	11.0~11.9	16	20	102	48	10.8	
MSQD-120/129-16-8D	12.0~12.9	16	20	110	48	11.8	12-16.9
MSQD-130/139-16-8D	13.0~13.9	16	20	119	48	12.8	
MSQD-140/149-16-8D	14.0~14.9	16	20	127	48	13.8	
MSQD-150/159-20-8D	15.0~15.9	20	25	136	50	14.8	
MSQD-160/169-20-8D	16.0~16.9	20	25	144	50	15.8	17-20.9
MSQD-170/179-20-8D	17.0~17.9	20	25	153	50	16.8	
MSQD-180/189-25-8D	18.0~18.9	25	32	161	56	17.8	
MSQD-190/199-25-8D	19.0~19.9	25	32	170	56	18.8	
MSQD-200/209-25-8D	20.0~20.9	25	32	178	56	19.8	21-26
MSQD-210/219-25-8D	21.0~21.9	25	32	187	56	20.8	
MSQD-220/229-25-8D	22.0~22.9	25	32	195	56	21.8	
MSQD-230/239-32-8D	23.0~23.9	32	42	204	60	22.8	
MSQD-240/249-32-8D	24.0~24.9	32	42	212	60	23.8	21-26
MSQD-250/259-32-8D	25.0~25.9	32	42	221	60	24.8	

Turning inserts

External turning

Internal turning

Grooving & parting

Threading

Milling

Boring & drilling

Tool holder

Solid carbide end mills

Solid carbide drill & taps

Technical information

Drills (coolant through center)

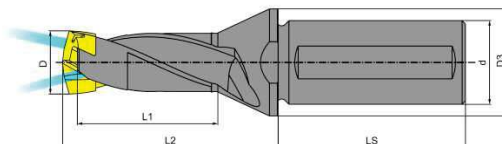

code number	Applicable cutting head Dia. (mm)	Dimensions (mm)					Wrench
		d	D3	L1	Ls	D	
MSQD-080/089-12-1.5D	8.0~8.9	12	16	16	45	7.8	8-11.9
MSQD-090/099-12-1.5D	9.0~9.9	12	16	18	45	8.8	
MSQD-100/109-16-1.5D	10.0~10.9	16	20	20	48	9.8	
MSQD-110/119-16-1.5D	11.0~11.9	16	20	22	48	10.8	
MSQD-120/129-16-1.5D	12.0~12.9	16	20	24	48	11.8	12-16.9
MSQD-130/139-16-1.5D	13.0~13.9	16	20	25	48	12.8	
MSQD-140/149-16-1.5D	14.0~14.9	16	20	27	48	13.8	
MSQD-150/159-20-1.5D	15.0~15.9	20	25	29	50	14.8	
MSQD-160/169-20-1.5D	16.0~16.9	20	25	30	50	15.8	17-20.9
MSQD-170/179-20-1.5D	17.0~17.9	20	25	32	50	16.8	
MSQD-180/189-25-1.5D	18.0~18.9	25	32	34	56	17.8	
MSQD-190/199-25-1.5D	19.0~19.9	25	32	36	56	18.8	
MSQD-200/209-25-1.5D	20.0~20.9	25	32	38	56	19.8	21-26
MSQD-210/219-25-1.5D	21.0~21.9	25	32	40	56	20.8	
MSQD-220/229-25-1.5D	22.0~22.9	25	32	42	56	21.8	
MSQD-230/239-32-1.5D	23.0~23.9	32	42	43	60	22.8	
MSQD-240/249-32-1.5D	24.0~24.9	32	42	45	60	23.8	
MSQD-250/259-32-1.5D	25.0~25.9	32	42	47	60	24.8	



code number	Applicable cutting head Dia. (mm)	Dimensions (mm)					Wrench
		d	D3	L1	Ls	D	
MSQD-080/089-12-3D	8.0~8.9	12	16	32	45	7.8	8-11.9
MSQD-090/099-12-3D	9.0~9.9	12	16	35	45	8.8	
MSQD-100/109-16-3D	10.0~10.9	16	20	39	48	9.8	
MSQD-110/119-16-3D	11.0~11.9	16	20	42	48	10.8	
MSQD-120/129-16-3D	12.0~12.9	16	20	45	48	11.8	12-16.9
MSQD-130/139-16-3D	13.0~13.9	16	20	49	48	12.8	
MSQD-140/149-16-3D	14.0~14.9	16	20	53	48	13.8	
MSQD-150/159-20-3D	15.0~15.9	20	25	56	50	14.8	
MSQD-160/169-20-3D	16.0~16.9	20	25	60	50	15.8	17-20.9
MSQD-170/179-20-3D	17.0~17.9	20	25	63	50	16.8	
MSQD-180/189-25-3D	18.0~18.9	25	32	66	56	17.8	
MSQD-190/199-25-3D	19.0~19.9	25	32	70	56	18.8	
MSQD-200/209-25-3D	20.0~20.9	25	32	73	56	19.8	21-26
MSQD-210/219-25-3D	21.0~21.9	25	32	77	56	20.8	
MSQD-220/229-25-3D	22.0~22.9	25	32	80	56	21.8	
MSQD-230/239-32-3D	23.0~23.9	32	42	84	60	22.8	
MSQD-240/249-32-3D	24.0~24.9	32	42	88	60	23.8	
MSQD-250/259-32-3D	25.0~25.9	32	42	91	60	24.8	

Turning inserts

External turning

Internal turning

Grooving & parting

Threading

Milling

Boring & drilling

Tool holder

Solid carbide end mills

Solid carbide drill & taps

Technical information

Forming Taps

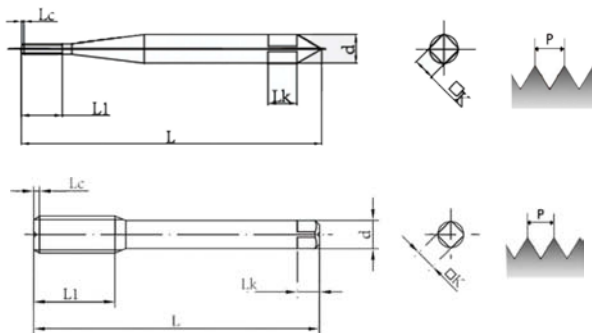

Material: HSSE Un t: mm

Order ng Code	L	L1	d	K	Natural color	T n	Als n-A	T cn
M1.0*0.25 RH4	32.5	3.5	3	2.5*3	●	○	○	○
M1.0*0.25 RH4	32.5	4.5	3	2.5*3	●	○	○	○
M1.2*0.25 RH4	32.5	3.5	3	2.5*3	●	○	○	○
M1.2*0.25 RH4	32.5	4.5	3	2.5*3	●	○	○	○
M1.4*0.30 RH4	37	6.5	3	2.5*3	●	○	○	○
M1.6*0.35 RH4	37	8	3	2.5*3	●	○	○	○
M1.7*0.35 RH4	37	8	3	2.5*3	●	○	○	○
M1.8*0.35 RH4	37	8	3	2.5*3	●	○	○	○
M2.0*0.40 RH5	45	10	3	2.5*3	●	○	○	○
M2.3*0.40 RH5	45	10	3	2.5*3	●	○	○	○
M2.5*0.45 RH5	45	13	3	2.5*3	●	○	○	○
M2.6*0.45 RH5	45	13	3	2.5*3	●	○	○	○
M3.0*0.50 RH7	50	16	4	3.2*6	●	○	○	○
M3.5*0.60 RH7	50	16	4	3.2*6	●	○	○	○
M4.0*0.70 RH7	57	18	5	4*7	●	○	○	○
M5.0*0.80 RH7	66	20	5.5	4.5*7	●	○	○	○
M6.0*1.00 RH7	62	24	6	4.5*7	●	○	○	○
M7.0*1.00 RH7	70	13	6.2	5*8	●	○	○	○
M8.0*1.00 RH7	70	13	6.2	5*8	●	○	○	○
M8.0*1.25 RH7	70	13	6.2	5*8	●	○	○	○
M10.0*1.00 RH7	75	13	7	5.5*8	●	○	○	○
M10.0*1.25 RH7	75	13	7	5.5*8	●	○	○	○
M10.0*1.50 RH7	75	15	7	5.5*8	●	○	○	○
M12.0*1.00 RH7	82	13	8.5	6.5*9	●	○	○	○
M12.0*1.25 RH8	82	13	8.5	6.5*9	●	○	○	○
M12.0*1.50 RH8	82	17	8.5	6.5*9	●	○	○	○
M12.0*1.75 RH8	82	17	8.5	6.5*9	●	○	○	○
M14.0*1.00 RH7	88	13	10.5	8*11	●	○	○	○
M14.0*1.25 RH7	88	13	10.5	8*11	●	○	○	○
M14.0*1.50 RH8	88	20	10.5	8*11	●	○	○	○
M14.0*2.00 RH8	88	20	10.5	10*13	●	○	○	○
M16.0*1.00 RH8	95	13	12.5	10*13	●	○	○	○
M16.0*1.25 RH8	95	13	12.5	10*13	●	○	○	○
M16.0*1.50 RH8	95	20	12.5	10*13	●	○	○	○
M16.0*2.00 RH9	95	20	12.5	10*13	●	○	○	○

● Stock ○ Available upon Order

Forming Taps

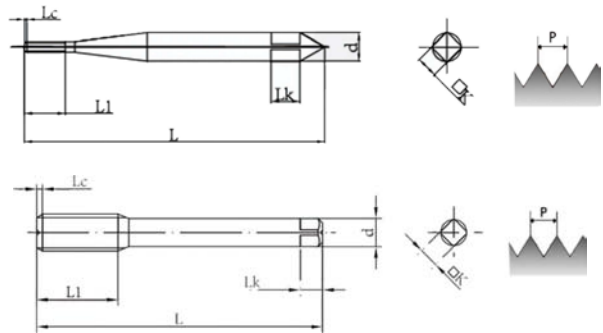

Material: HSSE Unit: mm

Ordering Code	L	L1	d	K	Natural color	Tin	Alsin-A	Ticn
NO.0-80UNF RH4	37	6.5	3	2.5*3	●	○	○	○
NO.1-64UNC RH4	37	9	3	2.5*3	●	○	○	○
NO.1-72UNF RH4	37	9	3	2.5*3	●	○	○	○
NO.2-56UNC RH4	45	12	3	2.5*3	●	○	○	○
NO.3-48UNC RH4	45	15	3	2.5*3	●	○	○	○
NO.4-40UNC RH4	45	15	3	2.5*3	●	○	○	○
NO.5-40UNF RH5	50	15	4	3.2*6	●	○	○	○
NO.6-32UNC RH6	50	16	4	3.2*6	●	○	○	○
NO.8-32UNC RH7	57	18	5	4*7	●	○	○	○
NO.10-24UNC RH7	66	20	5.5	4.5*7	●	○	○	○
NO.10-32UNF RH7	66	20	5.5	4.5*7	●	○	○	○
NO.12-24UNC RH7	66	20	5.5	4.5*7	●	○	○	○
NO.12-28UNF RH7	66	20	5.5	4.5*7	●	○	○	○
1/4-20UNC RH7	62	24	6	4.5*7	●	○	○	○
1/4-28UNF RH7	62	24	6	4.5*7	●	○	○	○
5/16-18UNC RH7	70	15	6.1	5*8	●	○	○	○
5/16-24UNF RH7	70	11	6.1	5*8	●	○	○	○
3/8-16UNC RH7	75	16	7	5.5*8	●	○	○	○
3/8-24UNF RH7	75	11	7	5.5*8	●	○	○	○
7/16-20UNF RH7	80	13	8	5*8	●	○	○	○
1/2-13UNC RH8	85	21	9	7*10	●	○	○	○
1/2-20UNF RH8	85	13	9	7*10	●	○	○	○
9/16-18UNF RH7	90	15	10.5	8*11	●	○	○	○
5/8-11UNC RH9	95	23	12	9*12	●	○	○	○
W1/40 RH6	50	15	4	3.2*6	●	○	○	○
W5/32-32 RH7	66	18	5	4*7	●	○	○	○
W3/16-24 RH7	66	18	5.5	4.5*7	●	○	○	○
W1/4-20 RH7	62	24	6	4.5*7	●	○	○	○
W5/16-18 RH7	70	15	6.1	5*8	●	○	○	○
W3/8-16 RH7	75	16	7	5.5*8	●	○	○	○
W1/2-12 RH8	85	21	9	7*10	●	○	○	○
W5/8-11 RH9	95	23	12	9*12	●	○	○	○

● Stock ○ Available upon Order

Turning inserts

External turning

Internal turning

Grooving & parting

Threading

Milling

Boring & drilling

Tool holder

Solid carbide end mills

Solid carbide drill & taps

Technical information

Cutting Taps

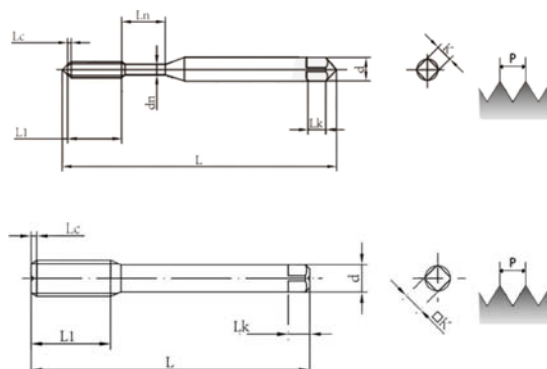

Material: HSSE Unit: mm

Ordering Code	L	L1	d	K	LK	dn	In	Natural color	T n	Als n-A	T cn
M1.0*0.25 P1	32	6.5	3	2.5	3			●	○	○	○
M1.2*0.25 P1	32	6.5	3	2.5	3			●	○	○	○
M1.4*0.30 P1	37	9.5	3	2.5	3			●	○	○	○
M1.6*0.35 P1	37	10	3	2.5	3			●	○	○	○
M2.0*0.40 P1	45	9	3	2.5	3	1.4	6	●	○	○	○
M2.5*0.45 P2	45	9	3	2.5	3	1.9	6	●	○	○	○
M3.0*0.50 P2	50	12	4	3.2	6	2.3	7	●	○	○	○
M3.5*0.60 P2	50	13	4	3.2	6	2.6	7	●	○	○	○
M4.0*0.70 P2	57	14	5	4	7	3	7	●	○	○	○
M5.0*0.80 P2	66	16	5.5	4.5	7	4	9	●	○	○	○
M6.0*1.00 P2	62	19.5	6	4.5	7	4.6	9.5	●	○	○	○
M8.0*1.25 P3	70	22	6.2	5	8			●	○	○	○
M8.0*1.00 P3	70	22	6.2	5	8			●	○	○	○
M10.0*1.50 P3	75	24	7	5.5	8			●	○	○	○
M10.0*1.25 P3	75	24	7	5.5	8			●	○	○	○
M10.0*1.00 P3	75	24	7	5.5	8			●	○	○	○
M12.0*1.75 P3	82	29	8.5	6.5	9			●	○	○	○
M12.0*1.50 P3	82	29	8.5	6.5	9			●	○	○	○
M12.0*1.25 P3	82	29	8.5	6.5	9			●	○	○	○
M12.0*1.00 P3	82	29	8.5	6.5	9			●	○	○	○
M14.0*2.00 P4	88	20	10.5	8	11			●	○	○	○
M14.0*1.50 P4	88	20	10.5	8	11			●	○	○	○
M14.0*1.25 P4	88	20	10.5	8	11			●	○	○	○
M14.0*1.00 P4	88	20	10.5	8	11			●	○	○	○
M16.0*2.00 P4	95	20	12.5	10	13			●	○	○	○
M16.0*1.50 P4	95	20	12.5	10	13			●	○	○	○
M16.0*1.25 P4	95	20	12.5	10	13			●	○	○	○
M16.0*1.00 P4	95	19.5	12.5	10	13			●	○	○	○

NO.4-40UNC P2	45	10	3	2.5	3	2	6	●	○	○	○
NO.5-40UNC P2	50	12	4	3.2	6	2.3	7	●	○	○	○
NO.6-32UNC P2	50	13	4	3.2	6	2.4	7	●	○	○	○
NO.8-32UNC P2	57	13.5	5	4	7	3	8	●	○	○	○
NO.10-24UNC P2	66	16.5	5.5	4.5	7	3.4	9.5	●	○	○	○
NO.12-24UNC P2	66	16.5	5.5	4.5	7	4	9.5	●	○	○	○
1/4-20UNC P2	62	19.5	6	4.5	7	4.6	9.5	●	○	○	○
5/16-18UNC P3	70	23	6.1	5	8			●	○	○	○
3/8-16UNC P3	75	24	7	5.5	8			●	○	○	○
7/16-14UNC P3	80	29	8	6	9			●	○	○	○
1/2-13UNC P3	85	30	9	7	10			●	○	○	○
9/16-12UNC P4	90	30	10.5	8	11			●	○	○	○
5/8-11UNC P4	95	23	12	9	12			●	○	○	○

● Stock ○ Available upon Order

Plug gauge' s specification



Material: HSSE Unit: mm

Ordering Code	Precision	Ordering Code	Precision
M1.0*0.25	5H	M7.0*1.00	6H
M1.2*0.25	5H	M8.0*1.25	6H
M1.4*0.30	6H	M8.0*1.00	6H
M1.6*0.35	6H	M10.0*1.50	6H
M1.7*0.35	6H	M10.0*1.25	6H
M1.8*0.35	6H	M10.0*1.00	6H
M2.0*0.40	6H	M12.0*1.75	6H
M2.3*0.40	6H	M12.0*1.50	6H
M2.5*0.45	6H	M12.0*1.25	6H
M2.6*0.45	6H	M12.0*1.00	6H
M3.0*0.50	6H	M14.0*2.00	6H
M3.5*0.60	6H	M14.0*1.50	6H
M4.0*0.70	6H	M16.0*2.00	6H
M5.0*0.80	6H	M16.0*1.50	6H
M6.0*1.00	6H		

Material: HSSE Unit: mm

Ordering Code	Precision	Ordering Code	Precision
M0.1-40 UNC	2B	1/2-13 UNC	2B
M0.5-40 UNC	2B	1/2-20 UNF	2B
M0.6-32 UNC	2B	9/16-12 UNC	2B
M0.8-32 UNC	2B	5/8-11 UNC	2B
M0.10-24 UNC	2B	5/8-18 UNF	2B
M0.10-32 UNF	2B	5/8-24 UNF	2B
M0.12-24 UNC	2B	W1/8-40	2B
M0.12-28 UNF	2B	W5/32-32	2B
1/4-20 UNC	2B	W3/16-24	2B
1/4-28 UNF	2B	W1/4-20	2B
5/16-18 UNC	2B	W5/16-18	2B
5/16-24 UNF	2B	W3/8-16	2B
3/8-16 UNC	2B	W1/2-12	2B
2/8-24 UNF	2B	W5/8-11	2B
7/16-14 UNC	2B		
7/16-20 UNF	2B		

plug gauge use HSS material, the size $\geq 3\text{mm}$ shadness in HRC53-60°, $> 3\text{mm}$ in HRC58-60°, GO-NO GO FIXED GAUGES's precision can be 5H,6H, also can be 6G,7H. size $\leq M1.4$ can be 5H, go gauge use GP to mark T=GO=GR, not-go-end USD IP to mark Z=NO=NR

NRT hole diameter calculating mode	
$1. dN = D - P \cdot 0.45$ $2. dN = D - 0.2P - 0.00403 \cdot P \cdot f1 + 0.0127 \cdot n$ Eg: M3*0.5 Rh6 JIS class 2 drill hole Thread overlap ratio 90% $dN = 3 - 0.2 \cdot 0.5 - 0.00403 \cdot 0.5 \cdot 90 + 0.0127 \cdot 6 = 2.79$	$dN = \text{Hole diameter}$ $D = \text{Diameter}$ $P = \text{Pitch}$ $f1 = \text{Thread overlap ratio}$ $n = RH$

● Stock ○ Available upon Order

Turning inserts

External turning

Internal turning

Grooving & parting

Threading

Milling

Boring & drilling

Tool holder

Solid carbide end mills

Solid carbide drill & taps

Technical information

Built for Professionals. Crafted for Performance.
As a trusted name in the CNC tooling industry,
TEKAT delivers more than tools
we deliver precision, reliability, and prestige.
Our philosophy is simple: when every micron matters,
perfection becomes the only standard.

TEKAT

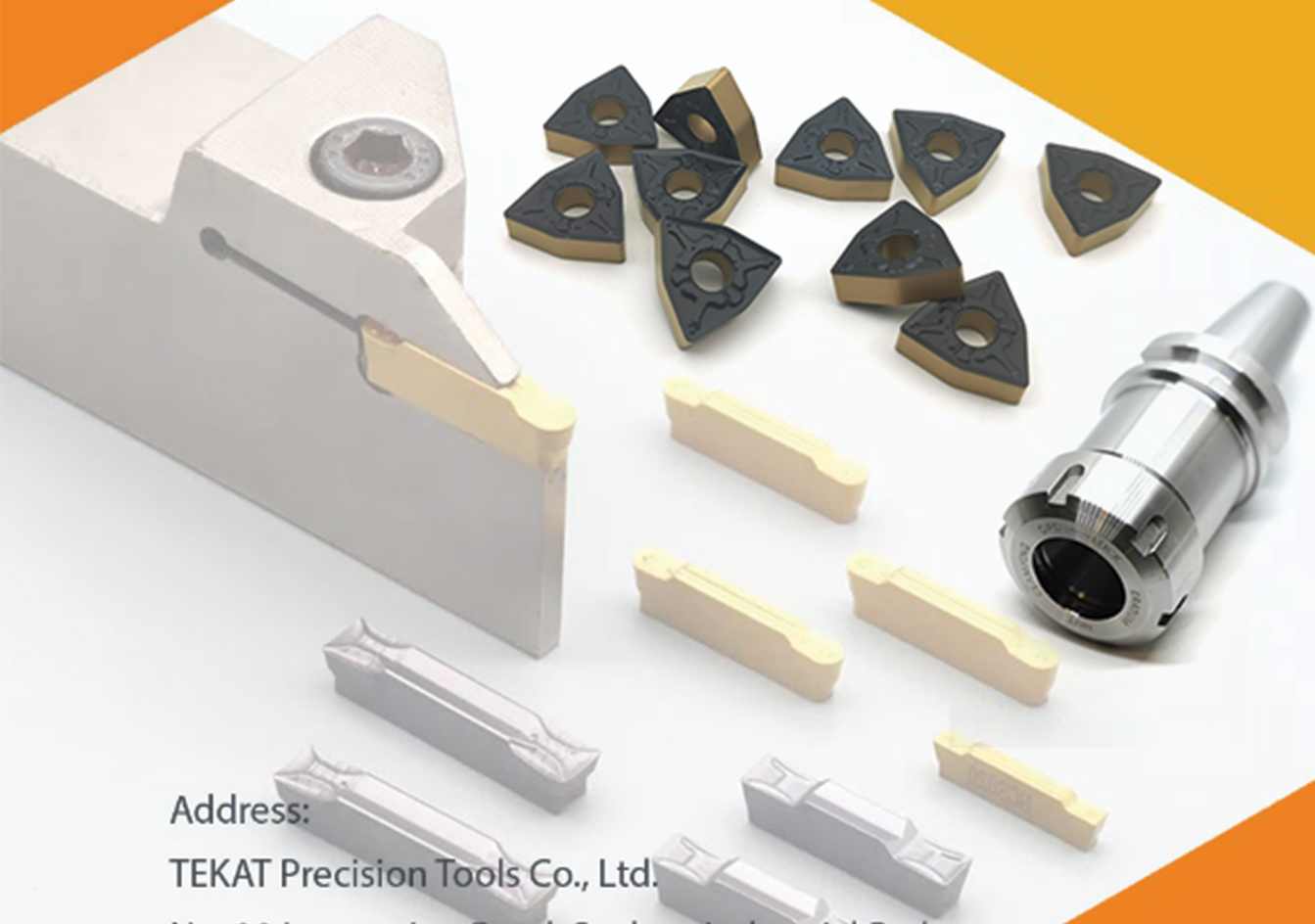

Address:

TEKAT Precision Tools Co., Ltd.

No. 88 Innovation Road, Suzhou Industrial Park,
Suzhou City, Jiangsu Province, China 215021